

Beta

programma
generale

2010



BETA: LA STORIA DELL'UTENSILERIA ITALIANA

1939

1923 - Alessandro Ciceri fonda la stamperia "Alessandro Ciceri & Figli", specializzata in stampi di ferro e acciaio.

1950

1939 - Viene depositato il marchio Beta e l'Azienda si specializza nella produzione di utensili per uso professionale.

1960 - Beta Utensili conta duecento dipendenti, esporta i propri prodotti all'estero e si afferma quale realtà emergente nel settore dell'utensileria professionale.

1969 - Nasce il rivoluzionario carrello "Tank" in lamiera arancione; il colore che - da quel momento in poi - renderà inconfondibile lo stile del marchio Beta.

1970

1971 - Beta Utensili entra nel mondo delle competizioni motoristiche intese come momento di verifica e sviluppo dei propri prodotti.

1975 - Arriva il primo grande successo in Formula 1 con la **March-Beta Utensili** di colore arancione di Vittorio Brambilla che vince il Gran Premio d'Austria nel diluvio di Zeltweg.

2007

1980 - Aumenta la penetrazione nei più importanti mercati Europei con la costituzione progressiva di filiali Beta Utensili in Francia, Gran Bretagna, Olanda, Spagna e Polonia.

1995 - In soli 8 mesi l'Azienda ottiene la certificazione **Sistema di Qualità ISO 9001**.

2000 - La presentazione del nuovo catalogo Beta Utensili conferma il continuo processo di crescita. Raddoppia la gamma dei prodotti in offerta e le oltre 10000 referenze vengono suddivise in 20 famiglie di prodotto.

2002 - L'offerta Beta Utensili viene ulteriormente ampliata con l'introduzione della gamma di calzature antinfortunistiche e la linea di abbigliamento da lavoro e tempo libero "Beta Work".

OGGI - Completato l'aggiornamento delle principali famiglie di utensili prosegue l'ampliamento della sezione automotive ed il progetto di revisione della gamma di cassettiere con la presentazione di nuovi modelli.



SOVICO

CASTIGLIONE

SULMONA

2 0 1 0



1995

Beta Utensili produce in Italia negli stabilimenti di Sovico (MB), Castiglione d'Adda (LO) e Sulmona (AQ). La superficie produttiva è distribuita su 32.500 metri quadri e impegna 550 dipendenti.

Beta Utensili rispetta l'ambiente dedicando particolare attenzione nella scelta di materiali e processi che garantiscano il minimo impatto sull'ecosistema.

Beta Utensili è presente nel Mondo grazie ad una performante struttura logistica e una capillare rete distributiva che comprende 7 filiali estere in Francia, Gran Bretagna, Olanda, Spagna, Polonia, Cina e Russia e punti vendita in oltre 200 paesi.

Beta Utensili è leader per qualità grazie ai rigorosi controlli sui propri prodotti e sui processi di attività aziendale secondo quanto stabilito dalla normativa ISO 9001.

Beta Utensili vince da quarant'anni. Un legame indissolubile - corrisposto dai migliori professionisti impegnati nella conquista di risultati prestigiosi - sancito nel tempo da collaborazioni con team prestigiosi, come Ferrari, Jordan, McLaren e Minardi in Formula 1 e Honda, Suzuki, Kawasaki e Yamaha nel MotoGP.



2009



1969

2006



2006



1976



2009

BETA UTENSILI S.p.A. - 20050 Sovico (MB)
Via A.Volta, 18 - Tel. 039.2077.1 - Telefax 039.2010742
www.beta-tools.com - info@beta-tools.com

Sede produttiva Accessori per funi Robur: 67039 Sulmona (AQ)
Zona industriale - C.da S. Nicola - Tel. 0864.2504.1 - Telefax 0864.253132
www.roburitaly.com - info@roburitaly.com

Deposito di Milano: Via Ferrante Aporti, 26
Tel. 02.28040686 - Telefax 02.28040679

Guida alla lettura

numero articolo

profilo utensile 

prezzo unitario

misura

numero utensili
nella confezione

numero utensili
nella serie

● tipo confezione

contenuto
della serie

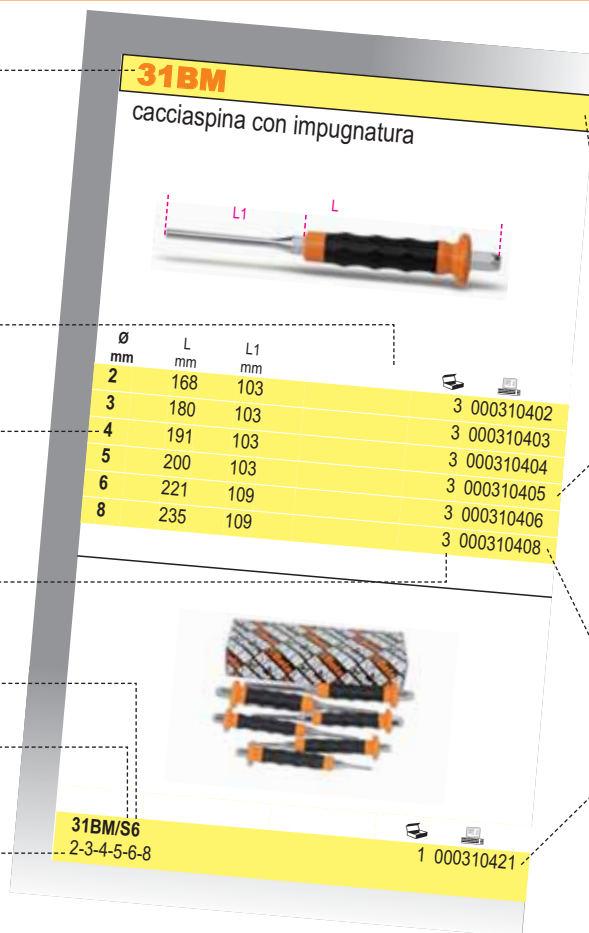

31BM
cacciaspina con impugnatura

Ø mm	L mm	L1 mm	
2	168	103	3 000310402
3	180	103	3 000310403
4	191	103	3 000310404
5	200	103	3 000310405
6	221	109	3 000310406
8	235	109	3 000310408

31BM/S6
2-3-4-5-6-8

1 000310421

in confezione blister

novità 2010

numero codice

Interpretazione delle sigle più correnti

Esempio

● nelle serie

B	= in busta di plastica	42/B6
BV	= busta vuota	42/BV6
C	= in cassetta	900/C11
D	= in confezione appendibile	1293/D6
S	= in scatola	42/S17
SP	= con supporto	42/SP17
SPV	= supporto vuoto	42/SPV1

negli assortimenti

AS	= con chiavi in pollici	5915U/AS1
E	= versione Elettronica/Elettrotecnica	2029E/6
I	= versione Idraulica	2009I/1
MT	= versione Movimento Terra	5902MT/1
U	= versione Universale	5915U3
VG	= versione Autoriparatori	5904VG/5
VI	= versione Industria	5902VI/1
M	= versione Motoriparazione	5940M1

nelle chiavi a bussola

A	= profilo esagonale	910A
B	= profilo poligonale	910B
ES	= profilo esascalato	920ES
FTX	= per viti TORX®	910FTX

Interpretazione delle sigle più correnti

Esempio

PT	= per viti pentalobate	910PT
X	= cricchetto reversibile nelle cassette	920A/C12X

nei giravite e inserti per avvitatori

LP	= per viti con intaglio	920LP
PE	= per viti con impronta esagonale	920PE
PH	= per viti con impronta PHILLIPS®	920PH
PZ	= per viti con impronta POZIDRIV® - SUPADRIV®	1299PZ
RTX	= per viti con impronta TAMPER RESISTANT TORX®	1298RTX
SP	= per viti con impronta SPANNER	861SP
TRW	= per viti con impronta TRI-WING®	861TRW
TQS	= per viti con impronta TORQ-SET®	861TQS
TX	= per viti con impronta TORX®	920TX
XZN	= per viti con impronta XZN®	920XZN

in generale

AS	= misure in pollici	42AS
BA	= utensili antisintilla	42BA
BM	= impugnatura bimateriale	1150BM
C	= contenitore metallico vuoto	C25
L	= modello lungo	952L
MQ	= utensili isolati a 1000V	1150MQ
MP	= finitura lucida	42MP
R	= ricambio	338R
TM	= impugnatura trimateriale	1152TM

Le immagini riprodotte sono indicative.

Beta Utensili S.p.A. si riserva il diritto di apportare aggiornamenti e migliorie alla propria gamma produttiva senza preavviso.



Beta RACCOMANDA

il corretto utilizzo degli utensili ed il rispetto
delle disposizioni per la sicurezza individuale.



30

punzoni



UNI 7501

Ø mm	L mm		
2	125	10	000300020
3	125	10	000300030
4	150	10	000300040
5	150	10	000300050
6	150	10	000300060

31

cacciaspina

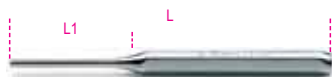

UNI 7502

Ø mm	L mm	L1 mm		
2	110	22	10	000310002
3	128	35	10	000310003
4	146	45	10	000310004
5	164	55	10	000310005
6	182	65	5	000310006
8	200	80	5	000310008
10	220	95	5	000310010



31/B6



31/SP6

31/B6	2-3-4-5-6-8	1	000310020
31/BV		1	000310021
31/SP6	2-3-4-5-6-8	1	000310030
31/SPV		1	000310031

31BM

cacciaspina con impugnatura



Ø mm	L mm	L1 mm		
2	168	103	3	000310402
3	180	103	3	000310403
4	191	103	3	000310404
5	200	103	3	000310405
6	221	109	3	000310406
8	235	109	3	000310408



31BM/S6	2-3-4-5-6-8	1	000310421
---------	-------------	---	-----------

31L

cacciaspina tipo lungo



Ø mm			
4		5	000310104
5		5	000310105
6		5	000310106

31SE

cacciaspina per spine elastiche

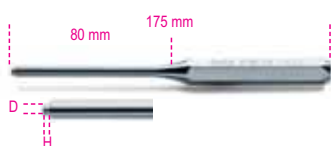

Ø mm	D mm	H mm		
4	2,4	2	5	000310204
5	3,0	2	5	000310205
6	3,6	2	5	000310206



31/B6-LSE	31L: 4-5-6 + 31SE: 4-5-6	1	000310320
31/BV-LSE		1	000310022

32

bulini



UNI 7503

Ø mm	L mm		
3	100	10	000320100
4	125	10	000320125
5	150	10	000320150

32AU

bulino automatico

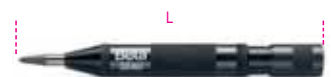

Ø mm	L mm		
3	150	2	000320160

32AUR

punta di ricambio



Ø mm			
3		5	000320170

34

scapelli piatti



UNI 7504

L mm	A mm		
125	14,5	5	000340001
150	17,0	5	000340002
175	21,5	5	000340003

35

scapelli nervati



UNI 7506

L mm	A mm		
100	14,5	10	000350001
125	17,0	10	000350002
150	20,5	10	000350003
200	23,0	10	000350004
250	28,5	3	000350005
300	34,0	3	000350006

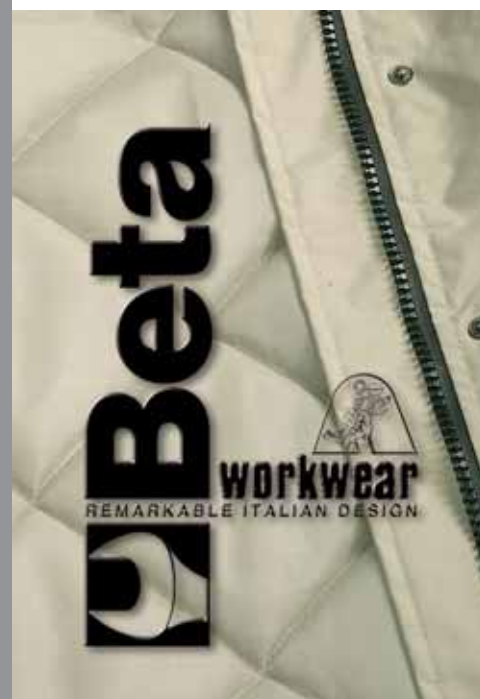

35PM

scalpelli nervati con paramano



L mm	A mm		
200	23,0	2	000350014
250	28,5	2	000350015
300	34,0	2	000350016

35PMR

ricambi paramano



L mm			
200		1	000350024
250		1	000350025
300		1	000350026

36

ugnetti



UNI 7505

L mm	A mm		
125	4	5	000360001
150	6	5	000360002

37

ugnetti nervati



UNI 7507

L mm	A mm		
150	6	5	000370001
200	8	3	000370002

37PM

ugnetto nervato con paramano



L mm	A mm		
200	8	2	000370012

37PMR

ricambio paramano



L mm			
200		1	000370022



38/B6



38/SP6

38/B6		1	000380006
30: 2-3			
32: 4			
34: 125-150			
36: 150			
38/BV		1	000380007
38/SP6		1	000380009
30: 2-3			
32: 4			
34: 125-150			
36: 150			
38/SPV		1	000380019

42

chiavi combinate



UNI/ISO 7738 DIN 3113

mm	L mm		
5,5x5,5	95	10	000420005
6x6	95	10	000420006
7x7	105	10	000420007
8x8	116	10	000420008
9x9	127	10	000420009
10x10	137	10	000420010
11x11	148	10	000420011
12x12	158	10	000420012
13x13	169	10	000420013
14x14	180	10	000420014
15x15	190	10	000420015
16x16	201	10	000420016
17x17	212	10	000420017
18x18	222	10	000420018
19x19	233	10	000420019
20x20	243	5	000420020
21x21	254	5	000420021
22x22	264	5	000420022
23x23	275	5	000420023
24x24	285	5	000420024
25x25	296	5	000420025
26x26	307	5	000420026
27x27	317	5	000420027
28x28	328	5	000420028
29x29	338	5	000420029
30x30	349	5	000420030
32x32	370	5	000420032
34x34	391	1	000420034

mm	L mm		
35x35	412	1	000420035
36x36	412	1	000420036
38x38	433	1	000420038
41x41	465	1	000420041



42/B6		1	000420049
6-7-8-10-11-13			
42/BV6		1	000420051
42/B9		1	000420064
6-7-8-10-11-13-14-17-19			
42/BV9		1	000420056



42/S15		1	000420066
6-7-8-10-11-12-13-14-17			
19-22-24-27-30-32			
42/S17		1	000420065
6-7-8-9-10-11-12-13-14			
15-16-17-18-19-20-21-22			
42/S26		1	000420070
6-7-8-9-10-11-12-13-14			
15-16-17-18-19-20-21			
22-23-24-25-26-27-28			
29-30-32			

42/SC9I-E

serie di 9 chiavi combinate con supporto compatto



42/SC9I		1	000420087
8-10-11-12-13-14-15-17-19			
42/SCV9I		1	000420103
42/SC9E		1	000420088
8-10-11-12-13-16-17-18-19			
42/SCV9E		1	000420104

Beta



42/SP17 1 000420075
6-7-8-9-10-11-12-13-14
15-16-17-18-19-20-21-22

42/SPV1 1 000420080

42/SP25 1 000420085
6-7-8-9-10-11-12-13-14
15-16-17-18-19-20-21
22-23-24-25-26-27-28
30-32

42/SPV2 1 000420090



42/SP15

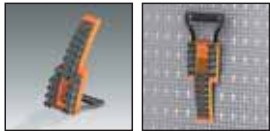

42/SPV...

42/SP15 1 000420078
6-7-8-9-10-11-12-13-14-15
16-17-19-22-24

42/SPV7 1 000420097
42-42MP: 8-10-11-13-14-17-19
55-55MP: 6x7-8x9-10x11-12x13
14x15-16x17-18x19

42/SPV11 1 000420100
42-42MP: 8-9-10-11-12-13
14-15-16-17-19
142-142SN: 8-9-10-11-12-13
14-15-16-17-19

42/SPV15 1 000420102
42-42MP: 6-7-8-9-10-11-12-13
14-15-16-17-19-22-24

42AS

chiavi combinate



mm	L mm		
1/4x1/4	95	5	000420106
5/16x5/16	116	5	000420108
3/8x3/8	137	5	000420110
7/16x7/16	148	5	000420111
1/2x1/2	169	5	000420113
9/16x9/16	180	5	000420114
5/8x5/8	201	5	000420116
11/16x11/16	212	5	000420117
3/4x3/4	233	5	000420119
13/16x13/16	254	5	000420121
7/8x7/8	264	5	000420122
15/16x15/16	285	2	000420124
1x1	296	2	000420125

mm	L mm		
1.1/16x1.1/16	317	2	000420127
1.1/8x1.1/8	338	2	000420129
1.1/4x1.1/4	370	2	000420132
1.5/16x1.5/16	391	1	000420133
1.3/8x1.3/8	412	1	000420135
1.7/16x1.7/16	412	1	000420136
1.1/2x1.1/2	433	1	000420138



42AS/B9 1 000420155
1/4-5/16-3/8-7/16-1/2
9/16-5/8-11/16-3/4



42AS/13 1 000420163
1/4-5/16-3/8-7/16-1/2-9/16
5/8-11/16-3/4-13/16-7/8
15/16-1

42MP

chiavi combinate lucide



UNI/ISO 7738 DIN 3113

mm	L mm		
6x6	95	5	000420606
7x7	105	5	000420607
8x8	116	5	000420608
9x9	127	5	000420609
10x10	137	5	000420610
11x11	148	5	000420611
12x12	158	5	000420612
13x13	169	5	000420613
14x14	180	5	000420614
15x15	190	5	000420615
16x16	201	5	000420616
17x17	212	5	000420617
18x18	222	5	000420618
19x19	233	5	000420619
20x20	243	3	000420620
21x21	254	3	000420621
22x22	264	3	000420622
24x24	285	3	000420624
27x27	317	3	000420627
30x30	349	3	000420630
32x32	370	3	000420632



42MP/B9 1 000420651
6-7-8-10-11-13-14-17-19

42/BV9 1 000420056



42MP/S17 1 000420652
6-7-8-9-10-11-12-13-14
15-16-17-18-19-20-21-22

42MP/S21 1 000420653
6-7-8-9-10-11-12-13-14
15-16-17-18-19-20-21-22
24-27-30-32

42MP/AS

chiavi combinate lucide



mm	L mm		
1/4x1/4	95	3	000420666
5/16x5/16	116	3	000420668
3/8x3/8	137	3	000420670
7/16x7/16	148	3	000420671
1/2x1/2	169	3	000420673
9/16x9/16	180	3	000420674
5/8x5/8	201	3	000420676
11/16x11/16	212	3	000420677
3/4x3/4	233	3	000420679
13/16x13/16	271	2	000420680
7/8x7/8	295	2	000420681
15/16x15/16	317	2	000420682
1x1	339	2	000420683
1.1/16x1.1/16	362	2	000420684
1.1/8x1.1/8	394	2	000420685
1.1/4x1.1/4	429	2	000420686



42MPAS/9 1 000420693
1/4-5/16-3/8-7/16-1/2
9/16-5/8-11/16-3/4

42MPAS/13 1 000420694
1/4-5/16-3/8-7/16-1/2
9/16-5/8-11/16-3/4
13/16-7/8-15/16-1



42LMP

chiavi combinate lunghe lucide



mm	L mm		
8x8	148	5	000420508
9x9	167	5	000420509
10x10	172	5	000420510
11x11	186	5	000420511
12x12	197	5	000420512
13x13	207	5	000420513
14x14	223	5	000420514
15x15	233	5	000420515
16x16	243	5	000420516
17x17	261	5	000420517
18x18	270	5	000420518
19x19	280	5	000420519
21x21	301	3	000420521
22x22	318	3	000420522
24x24	338	3	000420524
27x27	376	3	000420527
30x30	394	3	000420530
32x32	435	3	000420532



42LMP/S14	1	000420551
8-9-10-11-12-13-14		
15-16-17-18-19-21-22		
42LMP/S18	1	000420552
8-9-10-11-12-13-14		
15-16-17-18-19-21-22		
24-27-30-32		

45

chiavi combinate tipo pesante



UNI/ISO 7738 DIN 3113

mm	L mm		
46x46	520	1	000450046
50x50	560	1	000450050
55x55	610	1	000450055
60x60	660	1	000450060
65x65	710	1	000450065
70x70	760	1	000450070
75x75	810	1	000450075
80x80	860	1	000450080

52

chiavi a forchetta semplici



UNI 6733 DIN 3114

mm	L mm		
10	120	5	000520010
11	120	5	000520011
12	120	5	000520012
13	145	5	000520013
14	145	5	000520014
15	145	5	000520015
16	160	5	000520016
17	160	5	000520017
18	160	5	000520018
19	175	5	000520019
20	175	5	000520020
21	175	5	000520021
22	195	2	000520022
23	195	2	000520023
24	195	2	000520024
25	215	2	000520025
26	215	2	000520026
27	215	2	000520027
28	240	2	000520028
30	240	2	000520030
32	270	2	000520032
34	270	1	000520034
35	295	1	000520035
36	295	1	000520036
38	295	1	000520038
40	335	1	000520040
41	335	1	000520041
42	335	1	000520042
45	370	1	000520045
46	370	1	000520046
48	370	1	000520048
50	415	1	000520050
52	415	1	000520052
55	415	1	000520055
60	490	1	000520060
65	490	1	000520065
70	490	1	000520070

52MQ

chiavi a forchetta semplici



EN 60900

mm	L mm		
10	110	2	000520110
11	120	2	000520111
12	132	2	000520112
13	140	2	000520113
14	146	2	000520114
15	166	2	000520115
17	168	2	000520117
19	176	2	000520119
22	200	2	000520122
24	225	2	000520124

53

chiavi a forchetta DIN 894



mm	L mm		
19	178	5	000530019
22	219	5	000530022
24	219	5	000530024
27	241	5	000530027
30	267	5	000530030
32	285	5	000530032
36	317	1	000530036
38	320	1	000530038
41	342	1	000530041
46	396	1	000530046
50	412	1	000530050
55	457	1	000530055
60	492	1	000530060
65	528	1	000530065
70	572	1	000530070
75	608	1	000530075
80	645	1	000530080
85	690	1	000530085
90	690	1	000530090
95	847	1	000530095
100	847	1	000530100
105	1000	1	000530105
110	1000	1	000530110
115	1000	1	000530115
120	1000	1	000530120
125	1000	1	000530125
130	1000	1	000530130
135	1000	1	000530135



55

chiavi a forchetta doppia



UNI 10102 DIN 3110

mm	L mm		
4x5	100	10	000550003
5x5,5	100	10	000550006
5,5x7	120	10	000550009
6x7	120	10	000550012
7x8	140	10	000550018
8x9	140	10	000550021
8x10	140	10	000550024
10x11	155	10	000550030
10x12	155	10	000550033
10x13	170	10	000550035
12x13	170	10	000550042
12x14	170	10	000550045
13x14	185	10	000550047
13x17	189	10	000550051
14x15	185	10	000550054
14x17	189	10	000550057
16x17	202	10	000550060
17x19	220	5	000550063
18x19	220	5	000550066
19x22	236	5	000550069
20x22	236	5	000550075
21x23	245	5	000550078
22x24	245	5	000550081
24x26	262	5	000550087
24x27	262	5	000550090
25x28	272	5	000550096
27x29	284	5	000550099
27x30	284	5	000550102
27x32	295	5	000550105
30x32	295	5	000550108
32x36	325	1	000550114
34x36	325	1	000550117
35x38	375	1	000550120
36x41	375	1	000550123
41x46	425	1	000550129
46x50	475	1	000550132
50x55	500	1	000550135
55x60	500	1	000550138



55/B6	6x7-8x9-10x11-12x13 14x15-16x17	1	000550150
55/BV6		1	000550151
55/B8	6x7-8x9-10x11-12x13 14x15-16x17-18x19 20x22	1	000550158
55/BV8		1	000550159
55/B12	6x7-8x9-10x11-12x13 14x15-16x17-18x19 20x22-21x23-24x26 25x28-30x32	1	000550162
55/BV12		1	000550163



55/S8	6x7-8x9-10x11-12x13 14x15-16x17-18x19 20x22	1	000550174
55/S12	6x7-8x9-10x11-12x13 14x15-16x17-18x19 20x22-21x23-24x26 25x28-30x32	1	000550178
55/S12X	6x7-8x9-10x11-12x13 14x15-16x17-18x19 20x22-21x23-24x27 25x28-30x32	1	000550179
55/S13	6x7-8x9-10x11-12x13 14x15-16x17-18x19 20x22-21x23-24x26 25x28-27x29-30x32	1	000550182



55/SP7



55/SP13

55/SP7	6x7-8x9-10x11-12x13 14x15-16x17-18x19	1	000550167
42/SPV7	42-42MP: 8-10-11-13-14-17-19 55-55MP: 6x7-8x9-10x11-12x13 14x15-16x17-18x19	1	000420097
55/SP13	6x7-8x9-10x11-12x13 14x15-16x17-18x19 20x22-21x23-24x26 25x28-27x29-30x32	1	000550186
55/SPV		1	000550190

55AS

chiavi a forchetta doppia



mm	L mm		
1/4x9/32	120	5	000550203
1/4x5/16	120	5	000550206
5/16x11/32	140	5	000550209
5/16x3/8	140	5	000550212
3/8x7/16	155	5	000550215
7/16x1/2	170	5	000550218
1/2x9/16	170	5	000550221
9/16x5/8	185	5	000550224
19/32x11/16	189	2	000550227
5/8x11/16	202	2	000550230
5/8x3/4	202	2	000550233
11/16x13/16	220	2	000550242
3/4x7/8	236	2	000550245
25/32x13/16	236	2	000550244
7/8x15/16	245	2	000550251
15/16x1	262	1	000550257
1x1.1/8	272	1	000550259
1.1/16x1.1/4	295	1	000550267

mm	L mm		
1.1/8x1.5/16	295	1	000550266
1.5/16x1.1/2	325	1	000550269
1.3/8x1.1/2	375	1	000550272
1.7/16x1.5/8	375	1	000550275



55AS/5	5/16x11/32-3/8x7/16 1/2x9/16-5/8x11/16 3/4x7/8	1	000550290
55AS/7	5/16x11/32-3/8x7/16 1/2x9/16-5/8x3/4 11/16x13/16 7/8x15/16-1.1/8x1.5/16	1	000550295
55AS/11	1/4x9/32-5/16x11/32 3/8x7/16-1/2x9/16 19/32x11/16-5/8x3/4 25/32x13/16-7/8x15/16 1x1.1/8-1.1/16x1.1/4 1.1/8x1.5/16	1	000550300

55MP

chiavi a forchetta doppia lucide



UNI 10102 DIN 3110

mm	L mm		
6x7	120	2	000550603
8x9	140	2	000550606
10x11	155	2	000550609
12x13	170	2	000550612
14x15	185	2	000550615
16x17	202	2	000550618
18x19	220	2	000550621
20x22	236	2	000550624
21x23	245	2	000550627
24x26	262	3	000550630
25x28	272	3	000550633
27x29	284	3	000550636
30x32	295	3	000550639



55MP/S8	6x7-8x9-10x11-12x13 14x15-16x17-18x19 20x22	1	000550650
55MP/S13	6x7-8x9-10x11-12x13 14x15-16x17-18x19 20x22-21x23-24x26 25x28-27x29-30x32	1	000550651

58

chiavi a forchetta a percussione



DIN 133

mm	L mm		
27	180	1	000580027
30	190	1	000580030
32	190	1	000580032
36	215	1	000580036
41	235	1	000580041
46	255	1	000580046
50	275	1	000580050
55	300	1	000580055
60	320	1	000580060
65	342	1	000580065
70	375	1	000580070
75	375	1	000580075
80	408	1	000580080
85	408	1	000580085
90	445	1	000580090
95	445	1	000580095
100	485	1	000580100
105	485	1	000580105
110	510	1	000580110
115	510	1	000580115
120	545	1	000580120
125	545	1	000580125
130	575	1	000580130
135	575	1	000580135
140	575	1	000580140
145	640	1	000580145
150	640	1	000580150
155	640	1	000580155
160	640	1	000580160
165	715	1	000580165
170	715	1	000580170
175	715	1	000580175
180	715	1	000580180
185	715	1	000580185
190	800	1	000580190
195	800	1	000580195
200	800	1	000580200
210	800	1	000580210
220	800	1	000580220
230	800	1	000580230

73

chiavi a forchetta doppie piccole



UNI 6737

mm	L mm		
4x4	78	5	000730040
4,5x4,5	78	5	000730045
5x5	78	5	000730050
5,5x5,5	86	5	000730055
6x6	86	5	000730060
7x7	86	5	000730070
8x8	97	5	000730080
9x9	97	5	000730090
10x10	108	5	000730100
11x11	108	5	000730110
12x12	124	5	000730120
13x13	124	5	000730130
14x14	124	5	000730140



73/B13

4-4,5-5-5,5-6-7-8-9
10-11-12-13-14

1 000730200

73/BV

1 000730201



73/S13

4-4,5-5-5,5-6-7-8-9
10-11-12-13-14

1 000730210

78

chiavi poligonali a percussione



DIN 7444

mm	L mm		
24	163	1	000780024
27	180	1	000780027
30	190	1	000780030
32	190	1	000780032
36	205	1	000780036
41	230	1	000780041
46	240	1	000780046
50	255	1	000780050
55	270	1	000780055
60	280	1	000780060
65	300	1	000780065
70	330	1	000780070
75	330	1	000780075
80	360	1	000780080
85	360	1	000780085
90	390	1	000780090
95	390	1	000780095
100	420	1	000780100
105	420	1	000780105
110	450	1	000780110
115	450	1	000780115
120	480	1	000780120
125	480	1	000780125
130	520	1	000780130
135	520	1	000780135
140	520	1	000780140
145	580	1	000780145
150	580	1	000780150
155	580	1	000780155
160	580	1	000780160
165	650	1	000780165
170	650	1	000780170
175	650	1	000780175
180	650	1	000780180
185	700	1	000780185
190	700	1	000780190
195	700	1	000780195
200	700	1	000780200
210	750	1	000780210
215	750	1	000780215
220	750	1	000780220
230	750	1	000780230

80

chiavi a bussola poligonale snodate doppie



mm	L mm		
6x7	173	3	000800006
8x9	176	3	000800008
8x10	179	3	000800009
10x11	182	3	000800010
12x13	228	3	000800012
14x15	232	3	000800014
13x17	231	3	000800015
16x17	234	3	000800016
18x19	285	3	000800018
19x22	287	3	000800019
20x22	289	3	000800020
21x23	289	3	000800021
24x27	405	3	000800024
30x32	413	3	000800030

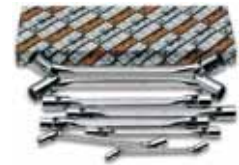

80/S8

6x7-8x9-10x11-12x13-14x15
16x17-18x19-20x22

1 000800051

80/S11

6x7-8x9-10x11-12x13
14x15-16x17-18x19-20x22
21x23-24x27-30x32

1 000800056

80AS

chiavi a bussola poligonale snodate doppie



mm	L mm		
3/8x7/16	182	1	000800510
1/2x9/16	228	1	000800513
19/32x5/8	234	1	000800515
11/16x3/4	285	1	000800516
13/16x7/8	287	1	000800521



80AS/5

3/8x7/16-1/2x9/16
19/32x5/8-11/16x3/4
13/16x7/8

1 000800550

83

chiavi poligonali per starter



ISO 3318

mm	L mm		
8x10	126	5	000830008
10x12	137	5	000830010
11x13	138	5	000830011
14x17	183	5	000830014
15x17	184	3	000830015
16x18	196	3	000830016
19x22	230	3	000830019



83/S3	11x13-14x17-19x22	1	000830081
83/S5	10x12-11x13-15x17-16x18-19x22	1	000830085

83AS

chiavi poligonali per starter



mm	L mm		
7/16x1/2	138	5	000830111
9/16x5/8	183	5	000830114
3/4x7/8	230	3	000830119



83AS/3	7/16x1/2-9/16x5/8-3/4x7/8	1	000830181
--------	---------------------------	---	-----------

89MQ

chiavi poligonali semplici



EN 60900

mm	L mm		
10	170	2	000890110
11	180	2	000890111
12	190	2	000890112
13	195	2	000890113
14	200	2	000890114
15	210	2	000890115
17	218	2	000890117
19	240	2	000890119
22	255	2	000890122
24	280	2	000890124

90

chiavi poligonali doppie curve



UNI 6740 DIN 838 ISO 10104

mm	L mm		
6x7	165	5	000900006
8x9	180	5	000900012
8x10	180	5	000900015
10x11	195	5	000900018
10x12	195	5	000900021
11x13	215	5	000900024
12x13	215	5	000900027
12x14	215	5	000900030
14x15	230	5	000900033
14x17	245	5	000900036
16x17	245	5	000900039
17x19	265	5	000900042
18x19	265	5	000900045
19x22	290	5	000900048
20x22	290	5	000900051
21x23	300	3	000900057
22x24	300	3	000900060
24x26	325	3	000900063
24x27	325	3	000900067
25x28	340	3	000900070
27x29	355	3	000900073
27x30	355	3	000900076
27x32	365	3	000900078
30x32	375	3	000900080
32x36	380	1	000900088
34x36	380	1	000900089
35x38	445	1	000900091
36x41	445	1	000900094
41x46	490	1	000900097
46x50	520	1	000900100



90/B8	6x7-8x9-10x11-12x13-14x15-16x17-18x19-20x22	1	000900154
90/BV8		1	000900155

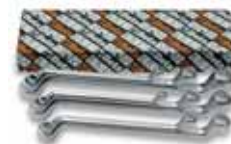

90/S8	6x7-8x9-10x11-12x13-14x15-16x17-18x19-20x22	1	000900162
90/S12	6x7-8x9-10x11-12x13-14x15-16x17-18x19-20x22-21x23-24x26-25x28-30x32	1	000900166
90/S12X	6x7-8x9-10x11-12x13-14x15-16x17-18x19-20x22-21x23-24x27-25x28-30x32	1	000900167
90/S13	6x7-8x9-10x11-12x13-14x15-16x17-18x19-20x22-21x23-24x26-25x28-27x29-30x32	1	000900170



90/SP13	6x7-8x9-10x11-12x13-14x15-16x17-18x19-20x22-21x23-24x26-25x28-27x29-30x32	1	000900174
55/SPV		1	000550190

90AS

chiavi poligonali doppie curve



mm	L mm		
1/4x5/16	165	2	000900203
5/16x11/32	180	2	000900206
5/16x3/8	180	2	000900209
3/8x7/16	195	2	000900212
7/16x1/2	215	2	000900215
1/2x9/16	215	2	000900218
9/16x5/8	230	2	000900221
5/8x11/16	245	2	000900224
5/8x3/4	265	2	000900227
11/16x3/4	265	1	000900230
11/16x13/16	265	1	000900233
3/4x7/8	290	1	000900237
13/16x7/8	290	1	000900240
7/8x15/16	300	1	000900243
15/16x1	325	1	000900252
1.1/16x1.1/4	365	1	000900258
1.1/8x1.5/16	365	1	000900261

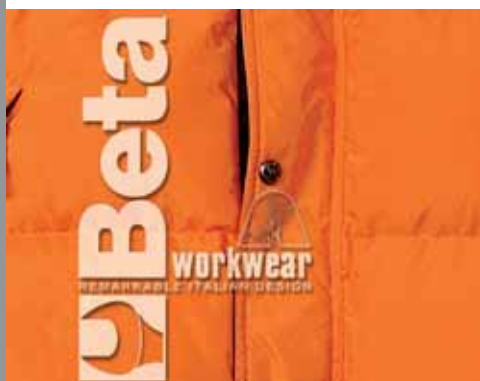



1 000900298

90AS/8
1/4x5/16-5/16x11/32
3/8x7/16-1/2x9/16
5/8x11/16-11/16x3/4
13/16x7/8-15/16x1

1 000900300

90AS/10
1/4x5/16-5/16x11/32
3/8x7/16-1/2x9/16
5/8x11/16-11/16x3/4
13/16x7/8-15/16x1
1.1/16x1.1/4-1.1/8x1.5/16

91

chiavi poligonali curve



mm	D mm	
24	38	1 000910024
27	41	1 000910027
30	48	1 000910030
32	49	1 000910032
36	54	1 000910036
41	62	1 000910041
46	69	1 000910046
50	76	1 000910050
55	81	1 000910055
60	90	1 000910060
65	98	1 000910065
70	105	1 000910070
75	110	1 000910075
80	125	1 000910080
85	125	1 000910085
90	140	1 000910090
95	140	1 000910095
100	143	1 000910100
105	146	1 000910105

92

leve di manovra per art. 91

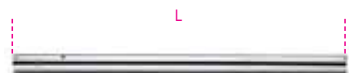

	L mm	91 mm	
92/1	460	24÷30	1 000920010
92/2	610	32÷41	1 000920020
92/3	760	46÷55	1 000920030
92/4	860	60÷105	1 000920040

93

chiave per ponteggi



mm	L mm	
21x22	310	3 000930021

93C

chiavi a cricchetto per ponteggi



mm	L mm	
13x17	280	1 000930113
17x19	315	1 000930117
19x22	315	1 000930119
19x24	360	1 000930120
21x22	315	1 000930121
27x30	450	1 000930127

94

chiavi per raccordi tubi



DIN 3118

mm	L mm	
8x10	150	3 000940008
9x11	150	3 000940009
10x11	155	3 000940010
11x13	165	3 000940011
12x14	190	3 000940012
14x15	190	2 000940014
14x17	197	2 000940015
17x19	215	2 000940017
19x22	230	2 000940019
22x24	245	2 000940022
24x27	260	2 000940024
30x32	288	2 000940030
36x41	320	1 000940036



1 000940050

94/S6
8x10-10x11-11x13-12x14
17x19-19x22

1 000940052

94/S10
8x10-9x11-10x11-11x13
12x14-17x19-19x22
22x24-24x27-30x32

94AS

chiavi per raccordi tubi



mm	L mm	
5/16x3/8	150	3 000940108
3/8x7/16	155	3 000940112
7/16x1/2	165	3 000940115
1/2x9/16	190	3 000940118
9/16x5/8	200	2 000940121
5/8x3/4	215	2 000940124
3/4x7/8	230	2 000940130



1 000940152

94AS/7
5/16x3/8-3/8x7/16
7/16x1/2-1/2x9/16
9/16x5/8-5/8x3/4
3/4x7/8

95

chiavi poligonali doppie diritte



DIN 837 ISO 10103

mm	L mm	
6x7	120	5 000950161
8x9	135	5 000950162
10x11	150	5 000950163
12x13	165	5 000950164
14x15	185	5 000950165
16x17	210	5 000950166
17x19	225	5 000950167
18x19	225	5 000950168
20x22	240	5 000950169
21x23	255	5 000950170
24x26	270	5 000950171
25x28	285	5 000950172
27x29	315	5 000950173
30x32	335	5 000950174



1 000950177

95/S8
6x7-8x9-10x11-12x13
14x15-16x17-18x19
20x22

1 000950179

95/S13
6x7-8x9-10x11-12x13
14x15-16x17-18x19
20x22-21x23-24x26
25x28-27x29-30x32

95P

chiavi poligonali doppie piegate



DIN 837 ISO 10103

mm	L mm	
6x7	120	5 000950185
8x9	135	5 000950186
10x11	150	5 000950187
12x13	165	5 000950188
14x15	185	5 000950189
16x17	210	5 000950190
18x19	225	5 000950191
20x22	240	5 000950192
21x23	255	5 000950193
24x26	270	5 000950194
25x28	285	5 000950195
27x29	315	5 000950196
30x32	335	5 000950197



95P/S8 1 000950200

6x7-8x9-10x11-12x13
14x15-16x17-18x19
20x22

95P/S13 1 000950202

6x7-8x9-10x11-12x13
14x15-16x17-18x19
20x22-21x23-24x26
25x28-27x29-30x32

95FTX

chiavi doppie dirette per viti
con teste a profilo Torx®



E6xE8 115 3 000950306

E10xE12 143 3 000950310

E14xE18 177 3 000950314

E20xE24 224 3 000950320



95FTX/S4 1 000950325

E6xE8-E10xE12
E14xE18-E20xE24

96

chiavi maschio esagonale piegate
cromate



UNI 6753 DIN 911 ISO 2936

1,5 45 14 20 000960015

2 50 16 20 000960020

2,5 56 18 20 000960025

3 63 20 20 000960030

3,5 66 22 20 000960035

4 70 25 20 000960040

4,5 75 26 20 000960045

5 80 28 20 000960050

6 90 32 20 000960060

7 95 34 10 000960070

8 100 36 10 000960080

9 106 38 10 000960090

10 112 40 10 000960100

11 119 42 10 000960110

12 125 45 10 000960120

13 132 50 10 000960130

14 140 56 10 000960140

16 160 60 5 000960160

17 160 63 5 000960170

mm	L mm	L1 mm		
19	180	70	5	000960190
22	200	80	3	000960220
24	224	90	1	000960240
27	250	100	1	000960270
30	280	112	1	000960300
32	315	125	1	000960312
36	355	140	1	000960316



96/ST6 3 000960370

2,5-3-4-5-6-8



96/PL7 1 000960371

2,5-3-4-5-6-8-10



96/B8 5 000960386

2-2,5-3-4-5-6-8-10

96/BV8 1 000960387

96/B10 5 000960380

1,5-2-2,5-3-4-5-6-8-10-12

96/BV10 1 000960381



96/SP9 5 000960384

1,5-2-2,5-3-4-5-6-8-10

96BP/SPV 1 000960982



96/SP12 1 000960390

2-2,5-3-3,5-4-4,5-5
6-7-8-9-10

96/SPV 1 000960400

96N

chiavi maschio esagonale piegate
brunite



UNI 6753 DIN 911 ISO 2936

0,9 30 10 20 000960409

1,3 40 13 20 000960413

1,5 45 14 20 000960415

2 50 16 20 000960420

2,5 56 18 20 000960425

3 63 20 20 000960430

3,5 66 22 20 000960435

4 70 25 20 000960440

4,5 75 26 20 000960445

5 80 28 20 000960450

6 90 32 20 000960460

7 95 34 10 000960470

8 100 36 10 000960480

9 106 38 10 000960490

10 112 40 10 000960500

11 119 42 10 000960510

12 125 45 10 000960520

13 132 50 10 000960530

14 140 56 10 000960540

16 160 60 5 000960560

17 160 63 5 000960570

19 180 70 5 000960590



96N/ST6 3 000960640

2,5-3-4-5-6-8



96N/G7 4 000960645

2,5-3-4-5-6-8-10

96N/G7A 4 000960643

1,5-2-2,5-3-4-5-6



96N/B10 5 000960650

1,5-2-2,5-3-4-5-6
8-10-12

96N/BV 1 000960651



5 000960658

96N/SP9
1,5-2-2,5-3-4-5-6-8-10

96BP/SPV 1 000960982



1 000960660

96N/SP12
2-2,5-3-3,5-4-4,5-5-6-7-8-9-10

96N/SPV 1 000960665

96AS

chiavi maschio esagonale piegate
brunite



	L mm	L1 mm	
1/30	30	10	20 000960698
3/64	45	14	20 000960700
1/20	40	13	20 000960701
1/16	46	15	20 000960702
5/64	50	16	20 000960704
3/32	53	17	20 000960706
7/64	57	20	20 000960708
1/8	57	23	20 000960710
9/64	60	23	20 000960712
5/32	66	25	20 000960714
3/16	71	29	20 000960716
7/32	80	31	20 000960718
1/4	87	32	20 000960720
5/16	99	40	10 000960724
3/8	111	44	10 000960728
7/16	125	47	10 000960730
1/2	132	50	10 000960732



3 000960740

96AS/T7
3/32-1/8-5/32
3/16-7/32-1/4-5/16



3 000960745

96AS/G7
3/32-1/8-5/32
3/16-1/4-5/16-3/8



1 000960746

96AS/PL7
3/32-1/8-5/32-3/16
1/4-5/16-3/8



1 000960750

96AS/B11
3/64-1/16-5/64-3/32
1/8-5/32-3/16-7/32
1/4-5/16-3/8

1 000960751

96AS/BV

96LC

chiavi maschio esagonale piegate
tipo lungo, cromate



mm	L mm	L1 mm	
2	100	16	20 000960320
2,5	112	18	20 000960321
3	126	20	20 000960322
3,5	133	22	20 000960323
4	140	25	20 000960324
4,5	150	26	20 000960325
5	160	28	20 000960326
6	180	32	20 000960327
7	190	34	10 000960328
8	200	36	10 000960329
9	212	38	10 000960330
10	224	40	10 000960331
12	250	45	10 000960332



2 000960335

96LC/SP8
2-2,5-3-4-5-6-8-10

96BP/SPV 1 000960982



1 000960336

96LC/SP12
2-2,5-3-3,5-4-4,5-5-6-7-8-9-10

96L/SPV 1 000960928

96L

chiavi maschio esagonale piegate
tipo lungo, brunite



mm	L mm	L1 mm	
2	100	16	20 000960820
2,5	112	18	20 000960825
3	126	20	20 000960830
3,5	133	22	20 000960835
4	140	25	20 000960840
4,5	150	26	20 000960845
5	160	28	20 000960850
6	180	32	20 000960860
7	190	34	10 000960870
8	200	36	10 000960880
9	212	38	10 000960890
10	224	40	10 000960900
12	250	45	10 000960920



2 000960925

96L/SP8
2-2,5-3-4-5-6-8-10

96BP/SPV 1 000960982



1 000960927

96L/SP12
2-2,5-3-3,5-4-4,5-5-6-7-8-9-10

96L/SPV 1 000960928

96BPC

chiavi maschio esagonale piegate
con estremità sferica, cromate



mm	L mm	L1 mm	
1,5	80	13	10 000960340
2	85	16	10 000960341
2,5	90	17	10 000960342
3	100	19	10 000960343
4	110	25	10 000960344
5	128	27	10 000960345
6	150	30	10 000960346
7	158	32	5 000960353
8	170	35	5 000960347
10	190	40	5 000960348



96BPC/SP9
1,5-2-2,5-3-4-5-6-8-10 1 000960351

96BP/SPV
1 000960982

96BP

chiavi maschio esagonale
piegate con estremità sferica, brunite

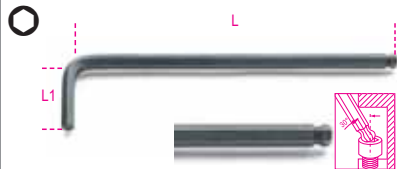

mm	L mm	L1 mm		
1,5	80	14	10	000960960
2	86	16	10	000960961
2,5	90	18	10	000960962
3	90	20	10	000960963
4	100	25	10	000960965
5	117	29	10	000960967
6	135	32	10	000960968
8	152	36	5	000960970
10	173	41	5	000960972



96BP/SP9
1,5-2-2,5-3-4-5-6-8-10 1 000960980

96BP/SPV
1 000960982

96BP/AS

chiavi maschio esagonale
piegate con estremità sferica, brunite

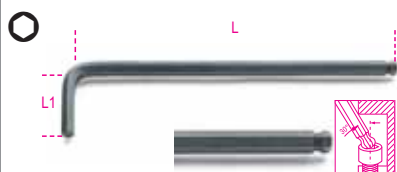

	L mm	L1 mm		
3/32	85	18	10	000960989
1/8	90	20	10	000960990
5/32	100	25	10	000960991
3/16	117	29	10	000960992
7/32	125	30	10	000960993
1/4	135	32	10	000960994
5/16	152	36	5	000960995
3/8	173	41	5	000960996



96BP/AS8
3/32-1/8-5/32-3/16-7/32
1/4-5/16-3/8 1 000960997

96BP/ASBV
1 000960998

96T

chiavi maschio esagonale piegate
con impugnatura di manovra

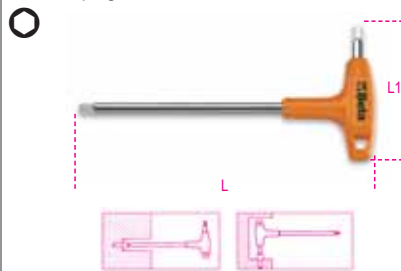

mm	L mm	L1 mm		
2	139	52	5	000960934
2,5	153	55	5	000960935
3	153	55	5	000960936
3,5	179	70	5	000960937
4	179	70	5	000960938
4,5	200	84	5	000960939
5	200	84	5	000960940
6	220	95	5	000960941
7	236	106	5	000960942
8	255	114	5	000960943
10	285	132	5	000960945



96T/S5
3-4-5-6-8 1 000960949

96T/S7
2,5-3-3,5-4-4,5-5-6 1 000960950



96T/SP11
2-2,5-3-3,5-4-4,5-5
6-7-8-10 1 000960957

96T/SPV
1 000960958

96T/AS

chiavi maschio esagonale piegate
con impugnatura di manovra

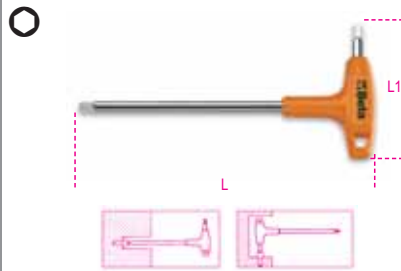

	L mm	L1 mm		
3/32	153	40	2	000960669
7/64	153	40	2	000960670
1/8	179	53	2	000960671
9/64	179	53	2	000960672
5/32	200	64	2	000960673
3/16	200	64	2	000960674
7/32	220	71	2	000960675
1/4	236	78	2	000960676
5/16	255	78	2	000960678
3/8	285	85	2	000960680



96TAS/10
3/32-7/64-1/8-9/64-5/32
3/16-7/32-1/4-5/16-3/8 1 000960683

96TBP

chiavi maschio esagonale piegate
con estremità sferica ed impugnatura
di manovra



mm	L mm	L1 mm		
2,5	153	55	5	000960685
3	153	55	5	000960686
4	179	70	5	000960687
5	200	84	5	000960688
6	220	95	5	000960689
8	255	114	5	000960690



96TBP/S5
2,5-3-4-5-6 1 000960695

97TX

chiavi maschio piegate
per viti con impronta Torx®



	L mm	L1 mm		
T6	42	16	5	000970006
T7	48	16	5	000970007
T8	48	16	5	000970008
T9	48	16	5	000970009
T10	51	17	5	000970010
T15	54	18	5	000970015
T20	57	19	5	000970020
T25	60	20	5	000970025
T27	64	21	5	000970027
T30	70	24	5	000970030
T40	76	26	5	000970040
T45	83	29	5	000970045
T50	95	32	5	000970050
T55	108	35	5	000970055
T60	120	38	5	000970060



3 000970640

97TX/ST8
T9-T10-T15-T20-T25
T27-T30-T40



3 000970645

97TX/G8
T9-T10-T15-T20-T25
T27-T30-T40



1 000970371

97TX/PL8
T9-T10-T15-T20-T25
T27-T30-T40



3 000970061

97TX/SP8
T9-T10-T15-T20-T25
T27-T30-T40

97/SPV 1 000970300



1 000970650

97TX/B13
T6-T7-T8-T9-T10-T15-T20
T25-T27-T30-T40-T45-T50

97TX/BV 1 000970651

97BTX

chiavi maschio piegate
con un'estremità sferica
per viti con impronta Torx®

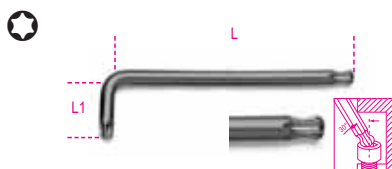

	L mm	L1 mm	
T9	64	16	5 000970109
T10	73	17	5 000970110
T15	83	17	5 000970115
T20	94	18	5 000970120
T25	96	18	5 000970125
T27	106	20	5 000970127
T30	119	24	5 000970130
T40	132	26	5 000970140
T45	137	29	5 000970145
T50	140	32	3 000970150
T55	145	35	3 000970155



2 000970161

97BTX/SP8
T9-T10-T15-T20-T25
T27-T30-T40

97/SPV 1 000970300



1 000970159

97BTX/B8
T9-T10-T15-T20-T25
T27-T30-T40

97BTX/BV 1 000970160

97RTX

chiavi maschio piegate
per viti con impronta
Tamper Resistant Torx®



	L mm	L1 mm	
T9	56	16	5 000970209
T10	62	17	5 000970210
T15	72	17	5 000970215
T20	83	18	5 000970220
T25	90	18	5 000970225
T27	100	20	5 000970227
T30	105	24	5 000970230
T40	112	26	5 000970240



3 000970261

97RTX/SP8
T9-T10-T15-T20-T25
T27-T30-T40

97/SPV 1 000970300



1 000970260

97RTX/B8
T9-T10-T15-T20-T25
T27-T30-T40

97RTX/BV 1 000970301

97TTX

chiavi maschio piegate
con impugnatura
per viti con impronta Torx®



	L mm	L1 mm	
T8	139	52	5 000970708
T9	139	52	5 000970709
T10	153	55	5 000970710
T15	153	55	5 000970715
T20	179	70	5 000970720
T25	179	70	5 000970725
T27	200	84	5 000970727
T30	200	84	5 000970730
T40	220	95	5 000970740
T45	236	106	3 000970745
T50	236	106	3 000970750



1 000970800

97TTX/S11
8-9-10-15-20-25
27-30-40-45-50



1 000970840

97TTX/SP11
8-9-10-15-20-25
27-30-40-45-50

96T/SPV 1 000960958

Beta



98XZN

chiavi a profilo XZN®



	L mm	L1 mm		
M5	72	25	5	000980005
M6	80	28	5	000980006
M8	90	32	5	000980008
M10	100	36	5	000980010
M12	112	40	5	000980012
M14	125	45	5	000980014
M16	140	55	5	000980016



98XZN/G5
M5-M6-M8-M10-M12 3 000980645



98XZN/PL5
M5-M6-M8-M10-M12 1 000980371



98XZN/B5
M5-M6-M8-M10-M12 1 000980650

98XZN/BV 1 000980651

99

chiavi a settore con nasello quadro
per ghiere



UNI 6752

mm	B mm		
12-14	1,0	5	000990012
16-18-20	1,3	5	000990016
22-25-28	1,7	5	000990022
30-32	1,8	5	000990030
34-36-38	1,9	5	000990034
40-42	1,9	5	000990040
45-50	1,9	5	000990045

mm	B mm		
52-55-58	1,8	5	000990052
62-65	2,4	5	000990062
68-70-75	2,4	5	000990068
80-85-90	3,0	3	000990080
92-95	3,5	3	000990092
98-100	3,5	3	000990098
105-110-115	3,5	3	000990105
120-125-130	4,0	3	000990120
135-145	5,0	1	000990135
155-165	6,0	1	000990155

99SQ

chiavi a settore articolate
con nasello quadro



mm	B mm		
15-35	2,7	3	000990215
35-50	3,5	3	000990235
50-80	4,7	3	000990250
80-120	6,2	2	000990280
120-180	7,8	2	000990290

99ST

chiavi a settore articolate
con nasello tondo



mm	B mm	Ø mm		
15-35	2,5	3	3	000990315
35-50	3,5	4	3	000990335
50-80	5,0	5	3	000990350
80-120	7,0	6	2	000990380
120-180	9,0	8	2	000990390

99 VN/...

nasello di ricambio per 99ST

mm			
99VN/15	15-35	1	000990295
99VN/35	35-50	1	000990296
99VN/50	50-80	1	000990297
99VN/80	80-120	1	000990298
99VN/120	120-180	1	000990299

100

chiave a compasso con naselli tonde



mm	L mm		
4,9-5,9	250	1	001000001
6,9-7,9			

100/KIT

naselli di ricambio per art. 100

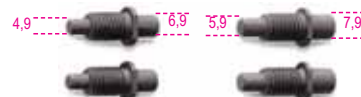

100/KIT 1 001000010

110

chiavi regolabili a rullino
con scala graduata



DIN 3117 ISO 6787

L mm	A max		
100	13	5	001100100
150	19	5	001100150
200	24	5	001100200
250	29	5	001100250
300	34	3	001100300
380	44	3	001100380
450	53	2	001100450
600	62	1	001100499

110PL

chiavi regolabili a rullino
con scala graduata
manici ricoperti con 2 strati
di PVC anticivolo



DIN 3117 ISO 6787

L mm	A max		
200	24	3	001100620
250	29	3	001100625
300	34	3	001100630

110MQ

chiave regolabile a rullino
con scala graduata



EN 60900

L mm	A max		
250	30	3	001100525

Beta

112N

chiavi regolabili a rullino
con scala graduata
fosfatate



DIN 3117 ISO 6787

L mm	A max		
100	13	5	001120010
150	19	5	001120015
200	24	5	001120020
250	29	5	001120025
300	34	3	001120030
380	44	3	001120038
450	53	2	001120045

120

chiavi poligonali aperte
a cricchetto

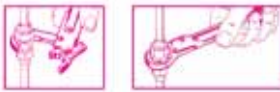

mm	L mm		
10	135	2	001200010
11	135	2	001200011
12	135	2	001200012
13	135	2	001200013
14	135	2	001200014
16	185	2	001200016
17	185	2	001200017
19	185	2	001200019
21	230	1	001200021
22	230	1	001200022
24	230	1	001200024
27	230	1	001200027
30	320	1	001200030
32	320	1	001200032



120/B6	10-11-13	17-19-22	1	001200050
120/BV			1	001200051

123E1/4

adattatore portainserti 1/4"
per chiavi a cricchetto 10 mm

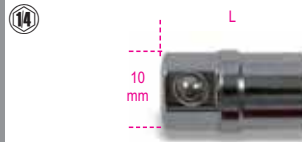

mm	L mm		
10	17,5	1	001230010

123Q1/4

adattatore a sgancio rapido 1/4"
per chiavi a cricchetto 10 mm

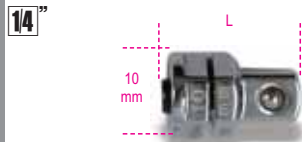

mm	L mm		
10	17,5	1	001230310

123Q3/8

adattatore a sgancio rapido 3/8"
per chiavi a cricchetto 13 mm

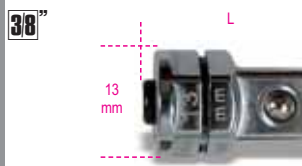

mm	L mm		
13	22,5	1	001230313

123Q1/2

adattatore a sgancio rapido 1/2"
per chiavi a cricchetto 19 mm



mm	L mm		
19	29,5	1	001230319

123/K4

kit di 4 adattatori per chiavi a cricchetto:
1 adattatore per bits
3 adattatori a sgancio rapido



123/K4			1	001230504
--------	--	--	---	-----------

142

chiavi combinate a cricchetto reversibile



mm	L mm		
6x6	135	3	001420006
7x7	135	3	001420007
8x8	135	3	001420008
9x9	142	3	001420009
10x10	158	3	001420010
11x11	167	3	001420011
12x12	173	3	001420012
13x13	180	3	001420013
14x14	190	2	001420014
15x15	200	2	001420015
16x16	215	2	001420016
17x17	230	2	001420017
18x18	238	2	001420018
19x19	245	2	001420019
22x22	284	1	001420022
24x24	324	1	001420024
27x27	355	1	001420027
30x30	420	1	001420030
32x32	420	1	001420032



142/B6	8-10-13-14-17-19	1	001420066
142/BV6		1	001420076
142/B9	8-10-11-12-13-14-15-17-19	1	001420069
142/BV9		1	001420079



142/S15	6-7-8-9-10-11-12-13	14-15-16-17-18-19-22	1	001420074	
142/S19	6-7-8-9-10-11-12	13-14-15-16-17-18	19-22-24-27-30-32	1	001420075

Beta
SHOP
in Shop

142/SC9I-E

serie di 9 chiavi combinate a cricchetto reversibile con supporto compatto



142/SC9I	1	001420087
8-10-11-12-13-14-15-17-19		
142/SCV9I	1	001420103
142/SC9E	1	001420088
8-10-11-12-13-16-17-18-19		
142/SCV9E	1	001420104

142AS

chiavi combinate a cricchetto reversibile



mm	L mm		
5/16x5/16	136	2	001420308
3/8x3/8	159	2	001420310
7/16x7/16	168	2	001420311
1/2x1/2	180	2	001420313
9/16x9/16	190	2	001420314
5/8x5/8	216	2	001420316
11/16x11/16	233	2	001420317
3/4x3/4	248	2	001420319



142AS/8	1	001420330
5/16-3/8-7/16-1/2		
9/16-5/8-11/16-3/4		

142C

chiavi combinate corte diritte a cricchetto



mm	L mm		
8x8	88	3	001420108
9x9	96	3	001420109
10x10	96	3	001420110
11x11	99	3	001420111
12x12	103	3	001420112
13x13	107	3	001420113
14x14	113	3	001420114
15x15	117	3	001420115
16x16	121	3	001420116
17x17	127	3	001420117
18x18	131	3	001420118
19x19	137	3	001420119



142C/A12	1	001420175
8-9-10-11-12-13-14		
15-16-17-18-19		

142SN

chiavi combinate a cricchetto snodate



mm	L mm		
8x8	136	2	001420208
9x9	143	2	001420209
10x10	161	2	001420210
11x11	169	2	001420211
12x12	175	2	001420212
13x13	178	2	001420213
14x14	194	2	001420214
15x15	201	2	001420215
16x16	217	2	001420216
17x17	233	2	001420217
18x18	238	2	001420218
19x19	250	2	001420219



142SN/S12	1	001420252
8-9-10-11-12-13-14		
15-16-17-18-19		

192

chiavi poligonali doppie diritte a cricchetto reversibile 4 in 1



mm	L mm		
8x10/12x13	160	1	001920008
16x17/18x19	230	1	001920016

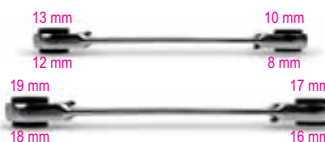

192/S2	1	001920070
8x10/12x13		
16x17/18x19 mm		

194

chiave portainseri a cricchetto reversibile



mm	L mm		
1/4x5/16	128	2	001940006

195

chiavi poligonali doppie diritte a cricchetto



mm	L mm		
8x10	128	2	001950010
12x13	170	2	001950013
14x15	190	2	001950015
16x18	230	2	001950018
17x19	230	2	001950019



195/B5	1	001950066
8x10-12x13-14x15		
16x18-17x19		

195/BV5	1	001950070
---------	---	-----------

195P

chiavi poligonali doppie piegate a 15° a cricchetto reversibile



mm	L mm		
8x10	128	2	001950210
12x13	170	2	001950213
14x15	190	2	001950215
16x18	230	2	001950218
17x19	230	2	001950219



195P/B5	1	001950266
8x10-12x13-14x15		
16x18-17x19		

195/BV5	1	001950070
---------	---	-----------

195FTX

chiavi poligonali doppie diritte a cricchetto con testa a profilo Torx®



	L mm		
E6xE8	128	2	001950406
E10xE12	170	2	001950410
E14xE18	190	2	001950414
E20xE24	230	2	001950420



195FTX/B4	1	001950501
E6xE8-E10xE12		
E14xE18-E20xE24		
195FTX/BV4	1	001950520

310

polifusori per saldatura tubi e raccordi in materiale plastico PE, PP, PVC e PVDF

CE



230V-650 Watt
50 Hz+60Hz
Shuko

310/1	1	003100001
Ø 16÷50		
310/2	1	003100002
Ø 16÷63		

310B

matrici per polifusore 310



Ø mm		
16	1	003100016
20	1	003100020
25	1	003100025
32	1	003100032
40	1	003100040
50	1	003100050
63	1	003100063

310/C4

polifusore con assortimento di 3 matrici



310/C4	1	003100104
310/1+310B: Ø 20-25-32		
410x260x82 mm - 4,8 kg		

310/C8

polifusore con assortimento di 7 matrici



310/C8	1	003100108
310/2+310B: Ø 16-20-25 32-40-50-63		
440x270x120 mm - 7,7 kg		

311

termopiastre per saldatura tubi in materiale plastico PE, PP, PVC e PVDF

CE



230V
50 Hz+60Hz
Shuko

	Ø mm	Watt	
311/1	120	900	1 003110001
311/2	190	900	1 003110002

312A

impugnatura per saldatura a gas



Ø	L mm	
M18x1	210	2 003120001

312B

impugnatura per saldatura a gas con leva comando di flusso rapido



Ø	L mm	
M18x1	210	2 003120005

312F

bruciatori a forcella



	A mm	L mm	kJ/h	
312F/40	40	240	24611	2 003120012

312G

gruppo mazza rame con cuffia e bruciatore Ø 22 mm



312G	L mm	Kj/h	
	180	9543	2 003120041

312G/RM

mazza di ricambio per 312G



312G/RM	2	003120046
---------	---	-----------

312G/RC

cuffia di protezione di ricambio per 312G



312G/RC	2	003120047
---------	---	-----------

Beta
Collection

312BR

bruciatori in ottone



	Ø mm	L mm	Kj/h		
312BR/10	10	120	1306	2	003120051
312BR/15	15	160	7534	2	003120053
312BR/17	17	160	9041	2	003120055
312BR/20	20	200	25113	2	003120057
312BR/20T	20	190	18081	2	003120059

312BR/A

bruciatori in acciaio



	Ø mm	L mm	Kj/h		
312BR/A45	45	90	46208	2	003120145
312BR/A60	60	110	175791	2	003120160
312BR/A90	90	140	190859	2	003120190

312PC

prolunghe curve



	L mm		
312PC/20	160	2	003120220
312PC/35	350	2	003120235
312PC/60	600	2	003120260
312PC/75	750	2	003120275

330

tagliatubi per tubi gas in acciaio



	Ø mm	L mm		
330/2	10÷60 mm 1/8"÷2" gas	380	1	003300002
330/4	60÷115 mm 2"÷4" gas	585	1	003300004

330R/A2 - 330R/A4

coltelli di ricambio per 330 per tubi in acciaio



	D mm		
330R/A2	32	1	003300012
330R/A4	42	1	003300014

330R/I

coltello di ricambio per 330 per acciaio INOX



	D mm		
330R/I	32	1	003300024

331L

tagliatubi a cricchetto per rame e leghe leggere



	Ø	L mm		
8÷29 mm		180	1	003310008
5/16"÷1"1/8				

332

mini-tagliatubi per rame e leghe leggere



	Ø	L mm		
3÷16 mm		59	2	003320001
1/8"÷5/8"				

334

tagliatubi per rame e leghe leggere



	Ø	L mm		
3÷30 mm		150	1	003340001
1/8"÷1"1/8				

334R

coltello di ricambio per 332-334 per rame e leghe leggere



	D mm		
334R	18,5	1	003340021

334R/I

coltello di ricambio per 332-334 per acciaio inox



	D mm		
334R/I	18,5	1	003340023

336

tagliatubi ad avanzamento telescopico per rame e leghe leggere



	Ø	L mm		
6÷38 mm		160	1	003360001
1/4"÷1"1/2				

338

tagliatubi ad avanzamento telescopico rapido per rame, leghe leggere e plastica



	Ø	L mm		
6÷67 mm		290	1	003380001
1/4"÷2"5/8				

338R

coltello di ricambio per 336 e 338 per rame e leghe leggere



	D mm		
338R	18,5	1	003380022

338R/I

coltello di ricambio per 336 e 338
per acciaio inox



	D mm	
338R/I	23,5	1 003380023

338RP

coltello di ricambio per 336 e 338
per plastica



	D mm	
338RP	23,5	1 003380025

339A

tagliatubi ad avanzamento telescopico
rapido per tubi di plastica



	∅ mm	L mm	
	50÷127 mm 2"÷5"	345	1 003390011

339A/R

coltelli di ricambio per 339A



	D mm	
339A/R	42	1 003390061

341

pinza tagliatubi
per tubi in materiale plastico



	∅ mm	L mm	
	0÷25	190	1 003410001

341RL

lama di ricambio per 341



341RL	1 003410010
-------	-------------

341B

cesoia a cricchetto
per tubi in materiale plastico



	∅ mm	L mm	
	0÷35	195	1 003410051

341B/RM

molla di ricambio per 341B

341B/RM	1 003410061
---------	-------------

341B/RL

lama di ricambio per 341B



341B/RL	1 003410060
---------	-------------

342

cesoia a cricchetto
per tubi in materiale plastico



	∅ max mm	L mm	
	42 mm 1"5/8	200	1 003420030

342MOL

molla di ricambio per 342

342MOL	1 003420033
--------	-------------

342RL

lama di ricambio per 342



342RL	1 003420032
-------	-------------

342A

cesoia a cricchetto
per tubi in materiale plastico



	∅ mm	L mm	
	0÷50	270	1 003420101

342A/MOL

molla di ricambio per 342A

342A/MOL	1 003420111
----------	-------------

342A/RL

lama di ricambio per 342A



342A/RL	1 003420110
---------	-------------

344

pinza allargatubi
per tubi di piombo

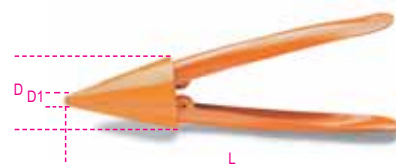

	L mm	D mm	D1 mm	
	240	53	11	1 003440001

345

utensile sbavatubi
corpo in metallo

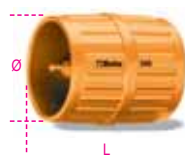

	∅ mm	L mm	
	3÷42 mm 1/8"÷1"5/8	58	5 003450001

345SB

sbavatore a raschietto
a lama intercambiabile girevole



L
mm
150 5 003450010

345SB/R

lama di ricambio per 345SB



345SB/R 3 003450015

350

attrezzo bordatubi
per rame e leghe leggere

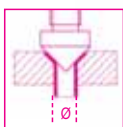

Ø
mm
4-4,75-6-8-10-12-14 1 003500001

351C

tagliatubi ed attrezzo bordatubi



351C 1 003510010

334 Ø 3÷30 mm (1/8"÷1"1/8)
350 Ø 4÷14 mm
351P Ø 4-4,75-6-8-10-12-14 mm

≡ 225x150x45 mm - 1,6 kg

351P

puntali per 350



Ø
mm
351P4 4 5 003510101
351P4,75 4,75 5 003510102
351P6 6 5 003510103
351P8 8 5 003510104
351P10 10 5 003510105
351P12 12 5 003510106
351P14 14 5 003510107

352

attrezzo bordatubi
per rame e leghe leggere

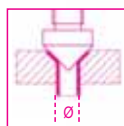

Ø
mm
4,75-5-6-8-10-12-14 1 003520001

352C

tagliatubi ed attrezzo bordatubi



352C 1 003520010

334 Ø 3÷30 mm (1/8"÷1"1/8)
352 Ø 4,75÷14 mm
352P Ø 4,75x0,7-5x0,7-6x0,7-8x0,7-10x0,7 mm
Ø 4,75x1-5x1-6x1-8x1-10x1 mm

352PR
≡ 418x160x59 mm - 3,3 kg

352PR

pressore per 352



352PR 5 003520050

352P

puntali per 352

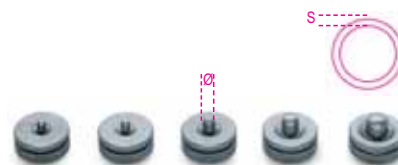

ØxS
mm
352P1/0,7 4,75x0,7 5 003520051
352P2/0,7 5x0,7 5 003520052
352P3/0,7 6x0,7 5 003520053
352P4/0,7 8x0,7 5 003520054
352P5/0,7 10x0,7 5 003520055
352P1/1 4,75x1,0 5 003520056
352P2/1 5x1,0 5 003520057
352P3/1 6x1,0 5 003520058
352P4/1 8x1,0 5 003520059
352P5/1 10x1,0 5 003520060

352U

attrezzo bordatubi regolabile,
per rame e leghe leggere

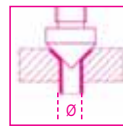

Ø
3/16÷5/8
(5÷16 mm) 1 003520101

352C/U

tagliatubi, sbavatore
ed attrezzo bordatubi regolabile



352C/U 1 003520110

334 Ø 1/8"÷1"1/8 (3÷30 mm)
345SB
352U Ø 3/16"÷5/8" (5÷16 mm)

≡ 335x145x60 mm - 2120 g

Beta



Beta
WORK

353N

pinza allargatubi a matrici ad espansione, intercambiabili



L mm	
380	1 003530201

353NM

matrici ad espansione per 353N



Ø mm	
10	1 003530210
12	1 003530212
14	1 003530214
16	1 003530216
18	1 003530218
22	1 003530222

353N/C6

pinza allargatubi 353N con matrici ad espansione 353NM



353N/C6	1 003530300
---------	-------------

353N
353NM Ø 10-12-14-16-18-22 mm
420x185x60 mm - 2,2 kg

355

chiave per raccordi radiatori a cinque graduazioni



Ø	L mm	
3/8"-1/2"	90	2 003550001
3/4"-1"		

357

dima regolabile con due filee per installazione idrosanitari

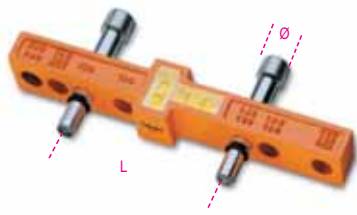

Ø	L mm	
1/2"	120÷220	1 003570001

358

attrezzi per smussare esternamente tubi in materiale plastico



	Ø mm	
358/1	16÷110	1 003580001
358/2	40÷250	1 003580002

358RL

lama di ricambio per 358/1 e 358/2



358RL	1 003580011
-------	-------------

359

chiave universale per pilette



Ø	L mm	
1"÷1"1/4	160	1 003590001

359CH

adattatore per pilette con grata a croce per 359



Ø	L mm	
1"1/2	74	1 003590005

360

giratubi modello Stillson



L mm	Ø max	Ø max mm	
250	1" gas	34	1 003600025
350	1"1/2 gas	49	1 003600035
450	2" gas	60	1 003600045
600	2"1/2 gas	76	1 003600060
900	3"1/2 gas	102	1 003600090

360R/...

KIT ricambio ganasce + ghiere per 360

360R/250	1 003600225
360R/350	1 003600235
360R/450	1 003600245
360R/600	1 003600260
360R/900	1 003600290

362

giratubi modello americano



L mm	Ø max	Ø max mm	
200	1" gas	34	1 003620020
250	1"1/2 gas	49	1 003620025
300	2" gas	60	1 003620030
350	2" gas	60	1 003620035
450	2"1/2 gas	76	1 003620045
600	3" gas	90	1 003620060

362R/...

KIT ricambi per 362

362R/200	1 003620220
362R/250	1 003620225
362R/300	1 003620230
362R/350	1 003620235
362R/450	1 003620245
362R/600	1 003620260

363

giratubi modello americano
corpo in lega leggera



L mm	Ø max gas	Ø max mm		
350	2" gas	60	1	003630035
450	2"1/2 gas	76	1	003630045
600	3" gas	90	1	003630060
900	5" gas	140	1	003630090

363R/...

KIT ricambi per 363

363R/350			1	003630235
363R/450			1	003630245
363R/600			1	003630260
363R/900			1	003630290

365

giratubi modello frontale
corpo in lega leggera



L mm	Ø max gas	Ø max mm		
350	2" gas	60	1	003650035
450	2"1/2 gas	76	1	003650045

365R/...

KIT ricambi completi per 365

365R/350			1	003650235
365R/450			1	003650245

366

giratubi tipo leggero



L mm	Ø max gas	Ø max mm		
175	1" gas	34	1	003660017
225	1"1/2 gas	49	1	003660022
275	2" gas	60	1	003660027
300	2"1/2 gas	76	1	003660030
350	3" gas	90	1	003660035

374

giratubi modello svedese
ganasce sottili a 45°



L ~	Ø max	Ø max mm		
240	1/2" gas	21	1	003740024
320	1" gas	34	1	003740032
410	1"1/2 gas	49	1	003740041
550	2" gas	60	1	003740055
630	3" gas	90	1	003740063

375

giratubi modello svedese
ganasce parallele a 45°



L ~	Ø max gas	Ø max mm		
320	1" gas	34	1	003750032
410	1"1/2 gas	49	1	003750041
550	2" gas	60	1	003750055

376

giratubi modello svedese
ganasce piane a 90°



L ~	Ø max gas	Ø max mm		
320	1" gas	34	1	003760032
410	1"1/2 gas	49	1	003760041
550	2" gas	60	1	003760055
630	3" gas	90	1	003760063

378

giratubi modello svedese
ganasce sottili a 45°



L ~	Ø max gas	Ø max mm		
250	1/2" gas	21	1	003780025
320	1" gas	34	1	003780032
410	1"1/2 gas	49	1	003780041
550	2" gas	60	1	003780055
650	3" gas	90	1	003780065

374R/...

KIT ricambi completi per 374 - 376 - 378

374R/240			1	003740724
x 374/240-378/250				
374R/320			1	003740732
x 374/320-376/320-378/320				
374R/410			1	003740741
x 374/410-376/410-378/410				
374R/550			1	003740755
x 374/550-376/550-378/550				
374R/630			1	003740763
x 374/630-378/650				

383

giratubi reversibili a nastro



	Ø max gas	Ø max mm		
383/1	3" gas	90	2	003830001
383/2	8" gas	220	2	003830002

383R

nastri di ricambio per 383



	S mm		
383R/1	27	1	003830010
x 383/1			
383R/2	27	1	003830015
x 383/2			

384

giratubo reversibile a catena



	Ø max gas	Ø max mm		
4" gas		115	1	003840032

384RC

catena di ricambio per 384



384RC		1	003840033

386A

giratubi reversibili a catena
modello pesante



	Ø gas	L mm		
386A/3	4" gas 115 mm	900	1	003860003
386A/4	6" gas 168 mm	900	1	003860004
386A/5	8" gas 220 mm	1100	1	003860005
386A/6	12" gas 324 mm	1300	1	003860006

386A/RC

catene di ricambio per 386A



386A3/RC x 386A/3	1	003860013
386A4/RC x 386A/4	1	003860014
386A5/RC x 386A/5	1	003860015
386A6/RC x 386A/6	1	003860016

388

attrezzi curvatubi
per rame, lega leggera e acciaio dolce

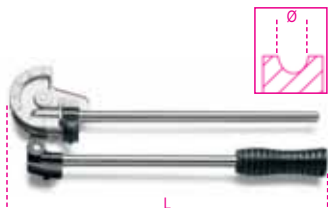

Ø mm	L mm	
6	305	1 003880006
8	315	1 003880008
10	350	1 003880010
12	360	1 003880012
14	455	1 003880014
15	465	1 003880015
16	465	1 003880016

388A

pinza curvatubi
per rame e lega leggera



388A/1	Ø 6-8-10 mm	1	003880051
388A/2	1/4"-5/16"-3/8"	1	003880055

392A

pinza regolabile per sifoni



Ø mm	L mm	
14÷62	235	1 003920001

392A/RG

coppia di copri-ganasce
di ricambio per 392A



392A/RG	1	003920051
---------	---	-----------

393

pinza per dadi rubinetto



L mm	
270	2 003930001

395

chiave per dadi rubinetto
articolata



Ø mm	L mm	
15÷32 mm 5/8"÷1"1/4	240	2 003950001

395T

chiave per dadi rubinetto
articolata, telescopica



Ø mm	L mm	
10÷32 mm 3/8"÷1"1/4	250÷430	2 003950100

395KS

chiavi a T per manovra



395KS	L mm	
	250	1 003950121

399

morse ribaltabili da banco



Ø mm	L min mm	
10÷60 mm 1/8÷2"	220	1 003990005
10÷89 mm 1/8÷3"	290	1 003990010

410

punte elicoidali cilindriche
serie corta, in acciaio HSS
rullate



DIN 338 ISO 235

Ø mm	L mm	
0,50	22	10 004100030
1,00	34	10 004100040
1,25	38	10 004100043
1,50	40	10 004100046
1,75	46	10 004100049
2,00	49	10 004100052
2,25	53	10 004100055
2,50	57	10 004100058
2,75	61	10 004100061
3,00	61	10 004100064
3,20	65	10 004100066
3,25	65	10 004100067
3,50	70	10 004100070
3,75	70	10 004100073
4,00	75	10 004100076
4,20	75	10 004100078
4,25	75	10 004100079
4,50	80	10 004100082
4,75	80	10 004100085
5,00	86	10 004100088
5,25	86	10 004100091
5,50	93	10 004100094
5,75	93	10 004100097
6,00	93	10 004100100
6,25	101	10 004100103
6,50	101	10 004100106
6,75	109	10 004100109



Ø mm	L mm		
7,00	109	10	004100112
7,50	109	10	004100118
8,00	117	10	004100124
8,50	117	10	004100130
9,00	125	5	004100136
9,50	125	5	004100142
10,00	133	5	004100148
10,50	133	5	004100172
11,00	142	5	004100184
11,50	142	5	004100196
12,00	151	5	004100210
12,50	151	5	004100222
13,00	151	5	004100234
14,00	160	5	004100242
15,00	169	5	004100250
16,00	178	5	004100258
17,00	186	3	004100262
18,00	194	3	004100266
19,00	202	3	004100270
20,00	210	3	004100274



410/SP19	1	004100419
Ø 1÷10 x 0,5 mm		
410/SPV1	1	004100420
410/SP25	1	004100425
Ø 1÷13 x 0,5 mm		
410/SPV2	1	004100426



410/SEL19	1	004100418
Ø 1÷10 x 0,5 mm		

410MIX/SEL19

serie di 13 punte 410
e 6 punte con inserto in metallo duro



410MIX/SEL19	1	004100417
---------------------	---	-----------



Ø 1 - 1,5 - 2 - 2,5 - 3 - 3,5 - 4
4,5 - 5 - 5,5 - 6 - 8 - 10 mm

Ø 4 - 5 - 6 - 8 - 9 - 10 mm

410A

punte elicoidali cilindriche
serie corta, in acciaio HSS rullate



DIN 338 ISO 235

Ø mm	L mm		
13,50	108	5	004100281
14,00	108	5	004100283
14,50	114	5	004100285
15,00	114	5	004100287
15,50	120	5	004100289
16,00	120	5	004100291
16,50	125	3	004100292
17,00	125	3	004100293
17,50	130	3	004100294
18,00	130	3	004100295
18,50	135	3	004100296
19,00	135	3	004100297
19,50	140	3	004100298
20,00	140	3	004100299

410AS

punte elicoidali cilindriche
serie corta, in acciaio HSS
rullate



ANSI B94

Ø "	L mm		
1/16	48	10	004100371
5/64	51	10	004100372
3/32	57	10	004100373
7/64	67	10	004100374
1/8	70	10	004100375
9/64	73	10	004100376
5/32	79	10	004100377
11/64	83	10	004100378
3/16	89	10	004100379

Ø "	L mm		
13/64	92	10	004100380
7/32	95	10	004100381
15/64	98	10	004100382
1/4	102	10	004100383
17/64	105	10	004100384
9/32	108	10	004100385
19/64	111	10	004100386
5/16	114	10	004100387
21/64	117	10	004100388
11/32	121	5	004100389
23/64	124	5	004100390
3/8	127	5	004100391
25/64	130	5	004100392
13/32	133	5	004100393
27/64	137	5	004100394
7/16	140	5	004100395
29/64	143	5	004100396
15/32	149	5	004100397
31/64	149	5	004100399
1/2	152	5	004100400



410AS/SP21	1	004100429
Ø 1/16-5/64-3/32-7/64 1/8-9/64-5/32-11/64-3/16 13/64-7/32-15/64-1/4 17/64-9/32-19/64-5/16 21/64-11/32-23/64-3/8		
410AS/SPV1	1	004100430

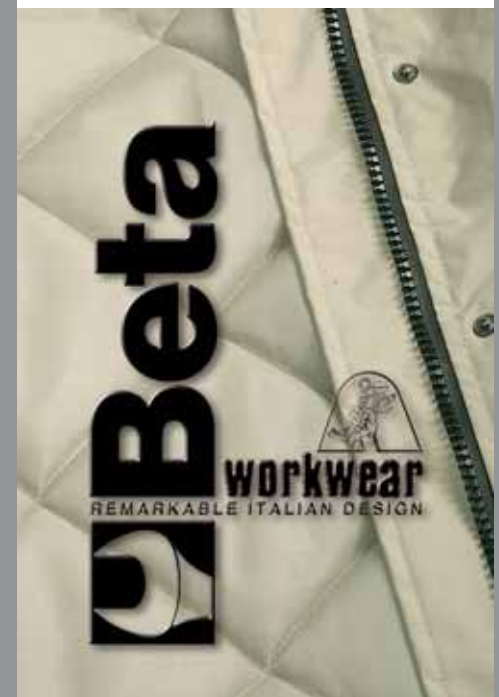

Beta



Beta

workwear
REMARKABLE ITALIAN DESIGN



1 004100433

410AS/SEL21
 Ø 1/16-5/64-3/32-7/64
 1/8-9/64-5/32-11/64-3/16
 13/64-7/32-15/64-1/4
 17/64-9/32-19/64-5/16
 21/64-11/32-23/64-3/8

412

punte elicoidali cilindriche
 serie corta, in acciaio HSS
 rettificata lucide



DIN 338 ISO 235

Ø mm	L mm	
0,50	22	10 004120030
1,00	34	10 004120040
1,25	38	10 004120043
1,50	40	10 004120046
1,75	46	10 004120049
2,00	49	10 004120052
2,25	53	10 004120055
2,50	57	10 004120058
2,75	61	10 004120061
3,00	61	10 004120064
3,25	65	10 004120067
3,50	70	10 004120070
3,75	70	10 004120073
4,00	75	10 004120076
4,25	75	10 004120079
4,50	80	10 004120082
4,75	80	10 004120085
5,00	86	10 004120088
5,25	86	10 004120091
5,50	93	10 004120094
5,75	93	10 004120097
6,00	93	10 004120100
6,25	101	10 004120103
6,50	101	10 004120106
6,75	109	10 004120109
7,00	109	10 004120112
7,25	109	5 004120115
7,50	109	5 004120118
7,75	117	5 004120121
8,00	117	5 004120124
8,25	117	5 004120127
8,50	117	5 004120130
8,75	125	5 004120133
9,00	125	5 004120136
9,25	125	5 004120139
9,50	125	5 004120142
9,75	133	5 004120145
10,00	133	5 004120148
10,25	133	5 004120149
10,50	133	5 004120150
10,75	142	5 004120151
11,00	142	5 004120152
11,25	142	5 004120153
11,50	142	5 004120154
11,75	142	5 004120155

Ø mm	L mm	
12,00	151	5 004120156
12,25	151	5 004120157
12,50	151	5 004120158
12,75	151	5 004120159
13,00	151	5 004120160



1 004120419

412/SP19	Ø 1÷10 x 0,5 mm	1 004120420
412/SPV1		1 004120425
412/SP25	Ø 1÷13 x 0,5 mm	
412/SPV2		1 004120426
412/SP49	Ø 1÷13 x 0,25 mm	1 004120449
412/SPV4		1 004120451

412/C150



1 004120450

412/C150		n.
	Ø 3 mm	20
	Ø 1 - 1,5 - 2 - 2,5 - 3,5 - 4 - 4,5 - 5 mm	10
	Ø 5,5 - 6 - 6,5 - 7 - 7,5 - 8 - 8,5 - 9 - 9,5 - 10 mm	5
	365x230x47 mm - 3390 g	



1 004120452

412/SP91	Ø 1÷10 x 0,10 mm	
-----------------	------------------	--

412A

punte elicoidali cilindriche
 serie corta, in acciaio HSS
 rettificata brunite



DIN 338 ISO 235

Ø mm	L mm	
13,50	160	3 004120202
14,00	160	3 004120204
14,50	169	3 004120206
15,00	169	3 004120208
15,50	178	3 004120210
16,00	178	3 004120212
16,50	186	1 004120213
17,00	186	1 004120214
17,50	194	1 004120215
18,00	194	1 004120216
18,50	202	1 004120217
19,00	202	1 004120218
19,50	210	1 004120219
20,00	210	1 004120220

412L

punte elicoidali cilindriche
 serie lunga, in acciaio HSS
 rettificata brunite



DIN 340 ISO 494

Ø mm	L mm	
2,00	85	10 004120232
2,50	95	10 004120234
3,00	100	10 004120236
3,50	112	10 004120238
4,00	119	10 004120240
4,50	126	10 004120242
5,00	132	10 004120244
5,50	139	10 004120246
6,00	139	10 004120248
6,50	148	5 004120250
7,00	156	5 004120252
8,00	165	5 004120256
9,00	175	5 004120260
10,00	184	5 004120264

414

punte elicoidali cilindriche
 serie corta, in acciaio HSS-TiN
 rettificata



DIN 338 ISO 235

Ø mm	L mm	
1,00	34	10 004140040
1,25	38	10 004140042
1,50	40	10 004140046
1,75	46	10 004140048
2,00	49	10 004140052
2,25	53	10 004140054
2,50	57	10 004140058
2,75	61	10 004140060
3,00	61	10 004140064

Ø mm	L mm		
3,25	65	10	004140066
3,50	70	10	004140070
3,75	70	10	004140072
4,00	75	10	004140076
4,25	75	10	004140078
4,50	80	10	004140082
4,75	80	10	004140084
5,00	86	10	004140088
5,25	86	10	004140090
5,50	93	10	004140094
5,75	93	10	004140096
6,00	93	10	004140100
6,25	101	10	004140102
6,50	101	10	004140106
6,75	109	10	004140108
7,00	109	10	004140112
7,25	109	5	004140114
7,50	109	5	004140118
7,75	117	5	004140120
8,00	117	5	004140124
8,25	117	5	004140125
8,50	117	5	004140130
8,75	125	5	004140132
9,00	125	5	004140136
9,25	125	5	004140138
9,50	125	5	004140142
9,75	133	5	004140144
10,00	133	5	004140148
10,50	133	5	004140150
11,00	142	5	004140152
11,50	142	5	004140154
12,00	151	5	004140156
12,50	151	5	004140158
13,00	151	5	004140160



414/SP19	1	004140419
Ø 1÷10 x 0,5 mm		
414/SPV1	1	004140420
414/SP25	1	004140425
Ø 1÷13 x 0,5 mm		
414/SPV2	1	004140426
414/SP49	1	004140429
Ø 1÷13 x 0,25 mm		
414/SPV4	1	004140430

414/C116



414/C116	1	004140450
----------	---	-----------

414	Ø 1 - 1,5 - 2 - 2,5 - 3 - 3,5 - 4 - 4,5 - 5 mm	n.
	Ø 5,5 - 6 - 6,5 - 7 - 7,5 - 8 mm	10
	Ø 8,5 - 9 - 9,5 - 10 mm	3
		2
	365x230x47 mm - 2680 g	

415

punte elicoidali cilindriche
serie corta, in acciaio HSS-CO 8%
rettificate



DIN 338 ISO 235

Ø mm	L mm		
0,50	22	10	004150029
1,00	34	10	004150040
1,25	38	10	004150043
1,50	40	10	004150046
1,75	46	10	004150049
2,00	49	10	004150052
2,25	53	10	004150055
2,50	57	10	004150058
2,75	61	10	004150061
3,00	61	10	004150064
3,25	65	10	004150067
3,50	70	10	004150070
3,75	70	10	004150073
4,00	75	10	004150076
4,25	75	10	004150079
4,50	80	10	004150082
4,75	80	10	004150085
5,00	86	10	004150088
5,25	86	10	004150091
5,50	93	10	004150094
5,75	93	10	004150097
6,00	93	10	004150100
6,25	101	10	004150103
6,50	101	10	004150106
6,75	109	10	004150109
7,00	109	10	004150112
7,25	109	5	004150115
7,50	109	5	004150118
7,75	117	5	004150121
8,00	117	5	004150124
8,25	117	5	004150127
8,50	117	5	004150130
8,75	125	5	004150133
9,00	125	5	004150136
9,25	125	5	004150139
9,50	125	5	004150142
9,75	133	5	004150145
10,00	133	5	004150148
10,25	133	5	004150149
10,50	133	5	004150150
10,75	142	5	004150151
11,00	142	5	004150152

Ø mm	L mm		
11,25	142	5	004150153
11,50	142	5	004150154
11,75	142	5	004150155
12,00	151	5	004150156
12,25	151	5	004150157
12,50	151	5	004150158
12,75	151	5	004150159
13,00	151	5	004150160
14,00	160	3	004150164
15,00	169	3	004150168
16,00	178	3	004150172
17,00	186	1	004150174
18,00	194	1	004150176
19,00	202	1	004150178
20,00	210	1	004150180



415/SP19	1	004150419
Ø 1÷10 x 0,5 mm		
415/SPV1	1	004150420
415/SP25	1	004150425
Ø 1÷13 x 0,5 mm		
415/SPV2	1	004150426
415/SP49	1	004150431
Ø 1÷13 x 0,25 mm		
415/SPV4	1	004150432

415/C116



415/C116	1	004150450
----------	---	-----------

415	Ø 1 - 1,5 - 2 - 2,5 - 3 - 3,5 - 4 - 4,5 - 5 mm	n.
	Ø 5,5 - 6 - 6,5 - 7 - 7,5 - 8 mm	10
	Ø 8,5 - 9 - 9,5 - 10 mm	3
		2
	365x230x47 mm - 2680 g	

Beta

Beta
Collection



415/SP91
Ø 1÷10 x 0,10 mm



1 004150460

416

punta cilindrica con affilatura speciale a doppia coppia di taglienti



VELOCITÀ DI TAGLIO SUPERIORE



DIN 338

Ø mm	L mm		
1,00	34	10	004160010
1,50	40	10	004160015
2,00	49	10	004160020
2,50	57	10	004160025
3,00	61	10	004160030
3,50	70	10	004160035
4,00	75	10	004160040
4,50	80	10	004160045
5,00	86	10	004160050
5,50	93	10	004160055
6,00	93	10	004160060
6,50	101	10	004160065
7,00	109	10	004160070
7,50	109	5	004160075
8,00	117	5	004160080
8,50	117	5	004160085
9,00	125	5	004160090
9,50	125	5	004160095
10,00	133	5	004160100

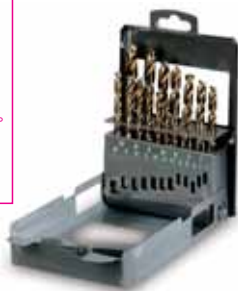

416/SP19
Ø 1÷10 x 0,5 mm



1 004160419

417

punte elicoidali cilindriche per muratura serie corta, in acciaio fresato con placchetta in metallo duro



DIN 8039

Ø mm	L mm		
3	70	10	004170003
4	75	10	004170004
5	85	10	004170005
5L	150	5	004170105
6	100	10	004170007
6L	150	5	004170106
7	120	10	004170009
8	120	10	004170010
8L	200	5	004170113
9	120	10	004170011
10	120	10	004170012
10L	200	5	004170120
12	150	10	004170014
12L	200	5	004170125
14	150	5	004170016
16	150	5	004170018



417/SP8
Ø 3-4-5-6-8-9-10-12 mm



1 004170100

419

punte per muratura corpo fresato con placchetta in metallo duro



DIN 8039

ØxL mm		
4x110	10	004190002
5x110	10	004190004
5x160	10	004190006
6x110	10	004190012
6x160	10	004190014
6x210	10	004190016
7x160	10	004190028
8x110	10	004190030
8x160	10	004190032
8x210	10	004190034
8x260	10	004190036
8x460	10	004190042
9x160	5	004190044



ØxL mm		
10x160	5	004190050
10x210	5	004190052
10x260	5	004190054
10x310	5	004190056
10x460	5	004190060
12x160	5	004190064
12x210	5	004190066
12x260	5	004190068
12x460	5	004190074
14x160	3	004190086
14x260	3	004190090
14x310	3	004190092
14x460	3	004190096
16x210	3	004190112
16x250	3	004190114
16x300	3	004190116
16x450	3	004190120
18x250	1	004190124
20x310	1	004190128

423

punte speciali per punti di saldatura in acciaio HSS, rettificate



Ø mm	L mm		
6	66	10	004230006
7	74	10	004230007
8	79	10	004230008
10	89	10	004230010

423A

frese speciali per punti di saldatura, in acciaio HSS rettificate



Ø mm	L mm		
6,5	40	1	004230015
8,0	40	1	004230020

424

punte coniche per forare ed allargare in acciaio HSS

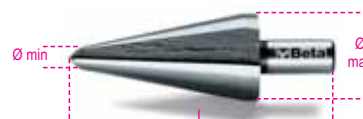

	L mm	Ø mm		
424/1	58	3÷14	3	004240001
424/2	63	6÷20	3	004240002
424/3	60	16÷30	3	004240003
424/4	80	3÷22	1	004240004
424/5	102	3÷31	1	004240005
424/6	86	26÷40	1	004240006
424/7	89	36÷50	1	004240007
424/8	90	40÷61	1	004240008



424/SP3	1	004240019
424/1+424/2+424/3		
Ø 3÷30 mm		
424/SPV	1	004240020

425

frese coniche a gradino
in acciaio HSS



	L mm	Ø mm	S mm		
425/1	70	4÷12	1	2	004250010
425/2	55	4÷12	2	2	004250012
425/3	85	4÷20	2	2	004250015
425/4	85	12÷20	1	2	004250016
425/5	97	20÷30	1	2	004250017
425/6	75	4÷30	2	2	004250020
425/7	97	30÷40	1	2	004250025
425/8	100	40÷50	1	2	004250029



425/SP3	1	004250030
425/1+425/3+425/6		
Ø 4÷30 mm		
425/SPV	1	004250035

426

frese a sbavare ed incassare
a tre taglienti
in acciaio HSS



GR	Ø mm	L mm		
1	4,3	44	5	004260001
2	5,3	44	5	004260002
3	6,3	44	5	004260003
4	7,3	44	5	004260004

GR	Ø mm	L mm		
5	8,3	50	5	004260005
6	9,4	50	5	004260006
7	10,4	54	5	004260007
8	12,4	54	5	004260008
9	15,0	56	5	004260009
10	16,5	60	5	004260010
11	20,5	63	5	004260011
12	25,0	66	5	004260012
13	28,0	71	5	004260013
14	31,0	71	5	004260014



426/SP6	1	004260030
GR 3-5-7-8-10-11		
Ø 6,3÷20,5 mm		
426/SPV	1	004260035

426SB

frese a sbavare e svasare
in acciaio HSS



	L mm	Ø mm		
426/SB1	45	10 - (2÷5)	1	004260101
426/SB2	48	14 - (5÷10)	1	004260102
426/SB3	65	21 - (10÷15)	1	004260103
426/SB4	85	28 - (15÷20)	1	004260104
426/SB5	102	35 - (20÷25)	1	004260105
426/SB6	115	44 - (25÷30)	1	004260106



426SB/SP4	1	004260130
426/SB1-426/SB2		
426/SB3-426/SB4		
Ø 2÷20 mm		
426SB/SPV1	1	004260135

426MD

lime rotative in metallo duro
taglio incrociato HM4



	L mm	Ø2 mm		
426MD/CP8	63	8	1	004260512
426MD/CP12	70	12	1	004260522
426MD/CT8	63	8	1	004260513
426MD/CT12	70	12	1	004260523
426MD/F8	63	8	1	004260514
426MD/F12	70	12	1	004260524
426MD/T8	63	8	1	004260516
426MD/T12	70	12	1	004260526
426MD/S8	52	8	1	004260518
426MD/S12	55	12	1	004260528
426MD/FA8	63	8	1	004260519
426MD/FA12	70	12	1	004260529



426MD/SP10	1	004260510
426MD/CP-426MD/CT-426MD/F		
426MD/T-426MD/S		
Ø 8-12 mm		

Beta



427

estrattori coni Morse



DIN 317

GR	L mm		
0	92	5	004270000
1-2	140	5	004270002
3	190	5	004270003
4	225	3	004270004
5-6	260	3	004270006

428FP

maschi a macchina per fori passanti
passo grosso
in acciaio HSS

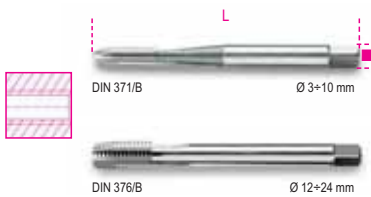

ISO 529

M	mm	L mm		
3x0,5	2,7	56	10	004280003
4x0,7	3,4	63	10	004280004
5x0,8	4,9	70	10	004280005
6x1	4,9	80	10	004280006
8x1,25	6,2	90	10	004280008
10x1,5	8,0	100	10	004280010
12x1,75	7,0	110	5	004280012
14x2	9,0	110	5	004280014
16x2	9,0	110	5	004280016
18x2,5	11,0	125	3	004280018
20x2,5	12,0	140	3	004280020
22x2,5	14,5	140	3	004280022
24x3	14,5	160	3	004280024

428FC

maschi a macchina per fori ciechi
passo grosso
in acciaio HSS

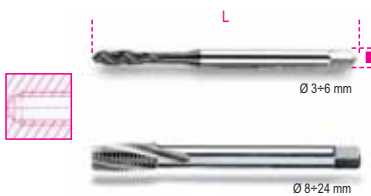

ISO 529

M	mm	L mm		
3x0,5	2,7	56	10	004280103
4x0,7	3,4	63	10	004280104
5x0,8	4,9	70	10	004280105
6x1	4,9	80	10	004280106
8x1,25	6,2	90	10	004280108
10x1,5	8,0	100	10	004280110
12x1,75	7,0	110	5	004280112
14x2	9,0	110	5	004280114
16x2	9,0	110	5	004280116
18x2,5	11,0	125	3	004280118
20x2,5	12,0	140	3	004280120
22x2,5	14,5	140	3	004280122
24x3	14,5	160	3	004280124

428/C14

assortimento di 14 maschi a macchina
428FP+428FC



428/C14
428FP M3÷12
428FC M3÷12

1 004280201

429FP

maschi a macchina per fori passanti
passo grosso
in acciaio HSS-CO 5%



ISO 529

M	mm	L mm		
3x0,5	2,7	56	5	004290003
4x0,7	3,4	63	5	004290004
5x0,8	4,9	70	5	004290005
6x1	4,9	80	5	004290006
8x1,25	6,2	90	5	004290008
10x1,5	8,0	100	5	004290010
12x1,75	7,0	110	5	004290012
14x2	9,0	110	5	004290014
16x2	9,0	110	5	004290016
18x2,5	11,0	125	3	004290018
20x2,5	12,0	140	3	004290020
22x2,5	14,5	140	3	004290022
24x3	14,5	160	3	004290024

429FC

maschi a macchina per fori ciechi
passo grosso
in acciaio HSS-CO 5%



ISO 529

M	mm	L mm		
3x0,5	2,7	56	5	004290103
4x0,7	3,4	63	5	004290104
5x0,8	4,9	70	5	004290105
6x1	4,9	80	5	004290106
8x1,25	6,2	90	5	004290108
10x1,5	8,0	100	5	004290110
12x1,75	7,0	110	5	004290112

M	mm	L mm		
14x2	9,0	110	5	004290114
16x2	9,0	110	5	004290116
18x2,5	11,0	125	3	004290118
20x2,5	12,0	140	3	004290120
22x2,5	14,5	140	3	004290122
24x3	14,5	160	3	004290124

429/C14

assortimento di 14 maschi a macchina
429FP+429FC



429/C14
429FP M3÷12
429FC M3÷12

1 004290201

430

serie di 3 maschi a mano
sgrossatore, intermedio, finitore
passo grosso, in acciaio al cromo



DIN 352 ISO 529

M	mm	L mm		
2x0,4	2,5	36	5	004300002
3x0,5	2,5	40	5	004300003
4x0,7	3,0	45	5	004300004
5x0,8	4,0	48	5	004300005
6x1	5,0	50	5	004300006
7x1	4,5	50	5	004300007
8x1,25	5,0	56	3	004300008
9x1,25	5,5	63	3	004300009
10x1,5	6,0	70	3	004300010
11x1,5	7,0	70	3	004300011
12x1,75	7,0	75	3	004300012
14x2	8,0	80	3	004300014
16x2	10,0	80	3	004300016
18x2,5	11,0	95	1	004300018
20x2,5	12,0	95	1	004300020
22x2,5	14,5	100	1	004300022
24x3	14,5	110	1	004300024





430/SP21	1	004300201
M 3-4-5-6-8-10-12		
430/SPV	1	004300202

430ASW

serie di 3 maschi a mano
sgrossatore, intermedio, finitore
Whitworth, in acciaio al cromo



DIN 352

BSW	mm	L mm		
1/8x40	2,7	40	5	004300031
5/32x32	3,4	45	5	004300032
3/16x24	4,3	48	5	004300033
1/4x20	4,9	50	5	004300034
5/16x18	4,9	56	3	004300035
3/8x16	5,5	70	3	004300036
7/16x14	6,2	70	3	004300037
1/2x12	7,0	75	3	004300038
9/16x12	9,0	80	1	004300039
5/8x11	9,0	80	1	004300040
3/4x10	11,0	95	1	004300041
7/8x9	14,5	100	1	004300042
1"x8	16,0	110	1	004300043

430ASC

serie di 3 maschi a mano
sgrossatore, intermedio, finitore
UNC, in acciaio al cromo



ANSI B1.1

UNC	mm	L mm		
1/4x20	4,9	70	5	004300051
5/16x18	4,9	70	5	004300052
3/8x16	5,5	75	3	004300053
7/16x14	6,2	80	3	004300054
1/2x13	7,0	85	3	004300055
9/16x12	9,0	90	3	004300056
5/8x11	9,0	100	3	004300057
3/4x10	11,0	110	3	004300058
7/8x9	14,5	120	1	004300059
1"x8	16,0	130	1	004300060

431

serie di 3 maschi a mano
sgrossatore, intermedio, finitore
passo grosso, in acciaio HSS



DIN 352 UNI 4535

M	mm	L mm		
3x0,5	2,5	40	5	004310003
4x0,7	3,0	45	5	004310004
5x0,8	4,0	48	5	004310005
6x1	5,0	50	5	004310006
7x1	5,0	50	5	004310007
8x1,25	5,0	56	3	004310008
10x1,5	6,0	70	3	004310010
12x1,75	7,0	75	3	004310012
14x2	9,0	80	1	004310014
16x2	9,0	80	1	004310016
18x2,5	11,0	95	1	004310018
20x2,5	12,0	95	1	004310020
22x2,5	12,0	100	1	004310022
24x3	14,5	110	1	004310024



431/SP21	1	004310201
M 3-4-5-6-8-10-12		
431/SPV	1	004310202

433

serie di 2 maschi a mano
sgrossatore e finitore
passo fine, in acciaio al cromo



DIN 2181 UNI 4535

M	mm	L mm		
6x0,75	4,5	48	5	004330201
7x0,75	4,5	56	5	004330202
8x0,75	5,0	50	5	004330203
8x1	5,0	56	5	004330204
9x0,75	6,0	63	5	004330205
9x1	6,0	63	5	004330206
10x0,75	6,5	63	5	004330207
10x1	6,5	63	5	004330208
10x1,25	6,5	63	5	004330209
11x0,75	7,0	70	3	004330210
11x1	7,0	70	3	004330211

M	mm	L mm		
11x1,25	7,0	70	3	004330212
12x0,75	7,0	70	3	004330213
12x1	7,0	70	3	004330214
12x1,25	7,0	70	3	004330215
12x1,5	7,0	70	3	004330216
14x1	8,0	80	1	004330217
14x1,25	8,0	80	1	004330218
14x1,5	8,0	80	1	004330219
16x1	10,0	80	1	004330220
16x1,5	10,0	80	1	004330221
18x1,5	11,0	95	1	004330222
18x2	11,0	80	1	004330223
20x1,5	14,5	80	1	004330224
22x1,5	14,5	80	1	004330225
24x1,5	14,5	80	1	004330226
24x2	14,5	80	1	004330227

433ASF

serie di 2 maschi a mano
UNF, passo fine
in acciaio al cromo



ANSI B1.1

UNF	mm	L mm		
1/4x28	4,9	70	5	004330301
5/16x24	4,9	70	5	004330302
3/8x24	5,5	75	3	004330303
7/16x20	6,2	80	3	004330304
1/2x20	7,0	85	3	004330305
9/16x18	9,0	90	3	004330306
5/8x18	9,0	100	3	004330307
3/4x16	11,0	110	3	004330308
7/8x14	14,5	120	1	004330309
1"x12	16,0	130	1	004330310

433ASG

serie di 2 maschi a mano
filettatura **GAS** cilindrica
in acciaio al cromo



DIN 353 UNI 338

GAS	mm	L mm		
1/8x28	4,9	65	1	004330401
1/4x19	5,5	70	1	004330402
3/8x19	6,2	75	1	004330403
1/2x14	7,0	80	1	004330405
3/4x14	9,0	90	1	004330408
1"x11	11,0	100	1	004330410



434

serie di 2 maschi a mano
sgrossatore e finitore
passo fine, in acciaio HSS



DIN 2181 UNI 4535

M	■ mm	L mm		
6x0,75	4,5	48	5	004340001
8x0,75	5,0	56	5	004340003
8x1	5,0	56	5	004340004
10x0,75	6,5	63	5	004340007
10x1	6,5	63	5	004340008
10x1,25	6,5	63	5	004340009
12x1	7,0	70	3	004340014
12x1,25	7,0	70	3	004340015
12x1,5	7,0	70	3	004340016
13x1,5	9,0	70	1	004340017
14x1	9,0	70	1	004340018
14x1,25	9,0	70	1	004340019
14x1,5	9,0	70	1	004340020
15x1,5	9,0	70	1	004340021
16x1	9,0	70	1	004340022
16x1,5	9,0	70	1	004340023
18x1,5	11,0	80	1	004340024
18x2	11,0	90	1	004340025
20x1,25	12,0	80	1	004340026
20x1,5	12,0	80	1	004340027
20x2	12,0	90	1	004340028
22x1,5	14,5	80	1	004340029
24x1	14,5	80	1	004340030
24x1,5	14,5	80	1	004340031
24x2	14,5	80	1	004340032

434ASF

serie di 2 maschi a mano
UNF, passo fine
in acciaio HSS



DIN 2181

UNF	■ mm	L mm		
NR 6x40	3,0	40	1	004340301
NR 8x36	4,9	40	1	004340302
NR 10x32	4,9	45	1	004340303
NR 12x28	4,9	50	1	004340304
1/4x28	4,9	50	1	004340305
5/16x24	4,9	56	1	004340306
3/8x24	5,5	63	1	004340307
7/16x20	6,2	63	1	004340308
1/2x20	7,0	75	1	004340309
9/16x18	9,0	80	1	004340310
5/8x18	9,0	80	1	004340311
3/4x16	11,0	95	1	004340312
7/8x14	14,5	100	1	004340313
1"x12	16,0	110	1	004340314

434ASG

serie di 2 maschi a mano
filettatura **GAS** cilindrica
in acciaio HSS



DIN 5157

GAS	■ mm	L mm		
1/8x28	5,5	63	1	004340401
1/4x19	9,0	63	1	004340402
3/8x19	9,0	70	1	004340403
1/2x14	12,0	80	1	004340404
5/8x14	14,0	90	1	004340405
3/4x14	16,0	100	1	004340406
7/8x14	18,0	100	1	004340407
1"x11	20,0	110	1	004340408

435

giramaschi regolabili
corpo in acciaio



DIN 1814

	□ mm	L mm		
435/0	2÷4,9	140	3	004350007
435/1	2,1÷5,5	180	2	004350009
435/1,5	2,1÷7,3	180	2	004350011
435/2	3,4÷9	260	2	004350013
435/3	4,9÷14	380	1	004350020
435/4	5,5÷16	490	1	004350027
x M9÷M27				
435/5	8÷18	620	1	004350032
x M13÷M32				

435G

giramaschi regolabili
corpo in lega leggera



DIN 1814

	□ mm	L mm		
435G/0	2÷5	130	5	004350108
x M1÷M8				
435G/1	2÷6,3	190	5	004350110
x M1÷M10				
435G/1,5	2,1÷8	217	5	004350112
x M1÷M12				
435G/2	3÷9	280	5	004350114
x M4÷M12				
435G/3	4,9÷12	380	2	004350121
x M5÷M20				
435G/4	5,5÷16	500	2	004350127
x M11÷M27				
435G/5	7÷18	700	1	004350132
x M13÷M32				
435G/6	11÷24	800	1	004350142
x M18÷M42				

436

giramaschi a cricchetto
reversibile

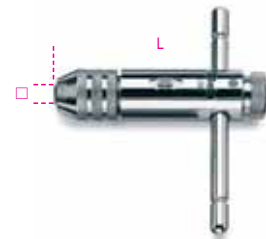

	□ mm	L mm		
436/1	2÷5	85	5	004360002
x M3÷M8				
436/2	4,6÷8	110	5	004360004
x M5÷M12				

436L

giramaschi a cricchetto
reversibile, tipo lungo



	□ mm	L mm		
436L/1	2÷5	245	2	004360012
x M3÷M8				
436L/2	4,6÷8	295	2	004360014
x M5÷M12				

436R

morsetti di ricambio per 436 e 436L

436R/1			1	004360022
436R/2			1	004360024

440

filiere tonde **passo grosso**
in acciaio al cromo



UNI EN 22568

M				
2x0,4			5	004400002
3x0,5			5	004400003
4x0,7			5	004400004
5x0,8			5	004400005
6x1			5	004400006
7x1			5	004400007
8x1,25			5	004400008
9x1,25			5	004400009
10x1,5			5	004400010
12x1,75			5	004400012

440A

filiere tonde **passo grosso**
in acciaio al cromo



UNI EN 22568

M		
10x1,5	3	004400110
11x1,5	3	004400111
12x1,75	3	004400112
14x2	3	004400114
16x2	3	004400116
18x2,5	3	004400118
20x2,5	3	004400120

440B

filiere tonde **passo grosso**
in acciaio al cromo



UNI EN 22568

M		
18x2,5	3	004400122
20x2,5	3	004400124
22x2,5	3	004400126
24x3	3	004400128

440ASW

filiere tonde **Whitworth**
in acciaio al cromo



BSW	Ø mm	
1/8x40	25,4	5 004400201
5/32x32	25,4	5 004400202
3/16x24	25,4	5 004400203
1/4x20	25,4	5 004400204
5/16x18	25,4	5 004400205
3/8x16	38,1	3 004400206
7/16x14	38,1	3 004400207
1/2x12	38,1	3 004400208
9/16x12	38,1	3 004400209
5/8x11	50,8	3 004400210
3/4x10	50,8	3 004400211
7/8x9	50,8	3 004400212
1"x8	50,8	3 004400213

440ASC

filiere tonde, **UNC**
passo grosso, in acciaio al cromo



UNC	Ø mm	
1/4x20	25,4	5 004400221
5/16x18	25,4	5 004400222
3/8x16	38,1	3 004400223
7/16x14	38,1	3 004400224
1/2x13	38,1	3 004400225
9/16x12	38,1	3 004400226
5/8x11	50,8	3 004400227
3/4x10	50,8	3 004400228
7/8x9	50,8	3 004400229
1"x8	50,8	3 004400230

440ASF

filiere tonde, **UNF**
passo fine, in acciaio al cromo



ANSI B1.1

UNF	Ø mm	
1/4x28	25,4	5 004400241
5/16x24	25,4	5 004400242
3/8x24	38,1	3 004400243
7/16x20	38,1	3 004400244
1/2x20	38,1	3 004400245
9/16x18	38,1	3 004400246
5/8x18	50,8	3 004400247
3/4x16	50,8	3 004400248
7/8x14	50,8	3 004400249
1"x12	50,8	3 004400250

440ASG

filiere tonde, filettatura **GAS** cilindrica
in acciaio al cromo



UNI 338 EN 22568

GAS	Ø mm	
1/8x28	38,1	3 004400255
1/4x19	38,1	3 004400256
3/8x19	38,1	3 004400257
1/2x14	50,8	3 004400259
3/4x14	50,8	3 004400260
1"x11	63,5	3 004400261

441

filiere tonde **passo fine**
in acciaio al cromo



DIN 223 EN 22568

M		
6x0,75	5	004410004
7x0,75	5	004410005
8x0,75	5	004410006
8x1	5	004410007
9x0,75	5	004410008
9x1	5	004410009

441A

filiere tonde **passo fine**
in acciaio al cromo



UNI EN 22568

M		
10x0,75	3	004410100
10x1	3	004410101
10x1,25	3	004410102
11x0,75	3	004410103
11x1	3	004410104
11x1,25	3	004410105
12x0,75	3	004410106
12x1	3	004410107
12x1,25	3	004410108
12x1,5	3	004410109
14x1	3	004410110
14x1,25	3	004410111
14x1,5	3	004410112
16x1	3	004410113
16x1,5	3	004410114
18x1,5	3	004410115

441B

filiere tonde **passo fine**
in acciaio al cromo



UNI EN 22568

M		
18x1,5	3	004410117
18x2	3	004410118
20x1,5	3	004410119
22x1,5	3	004410120
24x1,5	3	004410121
24x2	3	004410122



442

filiere tonde **passo grosso**
in acciaio HSS



UNI EN 22568

M	ØxS mm		
3x0,5	20x5	3	004420003
4x0,7	20x5	3	004420004
5x0,8	20x7	3	004420005
6x1	20x7	3	004420006
7x1	25x9	3	004420007
8x1,25	25x9	3	004420008
10x1,5	30x11	3	004420010
12x1,75	38x14	3	004420012
14x2	38x14	1	004420014
16x2	45x18	1	004420016
18x2,5	45x18	1	004420018
20x2,5	45x18	1	004420020
22x2,5	55x22	1	004420022
24x3	55x22	1	004420024

442ASG

filiere tonde, filettatura **GAS** cilindrica
in acciaio HSS



DIN 5158 ISO 4231 EN 22568

GAS	ØxS mm		
1/8x28	30x11	1	004420255
1/4x19	38x10	1	004420256
3/8x19	45x14	1	004420257
1/2x14	45x14	1	004420258
5/8x14	55x16	1	004420259
3/4x14	55x16	1	004420260
7/8x14	65x18	1	004420261
1"x11	65x18	1	004420262

443

filiere tonde, **passo fine**
in acciaio HSS



ISO 2568 EN 22568

M	ØxS mm		
6x0,75	20x7	1	004430107
8x0,75	25x9	1	004430110
8x1	25x9	1	004430111
10x0,75	30x11	1	004430113
10x1	30x11	1	004430114
10x1,25	30x11	1	004430115
12x1	38x10	1	004430116
12x1,25	38x10	1	004430117
12x1,5	38x10	1	004430118
13x1,5	38x10	1	004430119

M	ØxS mm		
14x1	38x10	1	004430120
14x1,25	38x10	1	004430121
14x1,5	38x10	1	004430122
15x1,5	38x10	1	004430123
16x1	45x14	1	004430124
16x1,5	45x14	1	004430125
18x1,5	45x14	1	004430127
20x1,25	45x14	1	004430129
20x1,5	45x14	1	004430130
20x2	45x14	1	004430131
22x1,5	55x16	1	004430132
24x1	55x16	1	004430133
24x1,5	55x16	1	004430135
24x2	55x16	1	004430136

444

girafilere, corpo in acciaio



UNI EN 22568

	Ø mm	L mm		
444	20x5	215	5	004440005
444/0	20x7	215	5	004440007
444/1	25,4	225	5	004440025
444/1A	25x9	225	5	004440027
444/1B	30x11	300	5	004440030
444/C	38x11	315	3	004440033
444/1C	38x10	315	3	004440035
444/2	38,1	360	3	004440038
444/1D	45x14	455	1	004440045
444/2D	45x18	455	1	004440046
444/3	50,8	555	1	004440050
444/4	55x16	555	1	004440055
444/5A	63,5	630	1	004440057

444G

girafilere, corpo in lega leggera



UNI EN 22568

	Ø mm	L mm		
444G/A	16x5	160	5	004440103
444G	20x5	200	5	004440105
444G/0	20x7	200	5	004440107
444G/1	25,4	210	5	004440125
444G/1A	25x9	224	5	004440127
444G/1B	30x11	280	5	004440130
444G/C	38x10	315	3	004440133
444G/1C	38x14	315	3	004440135
444G/2	38,1	320	3	004440138
444G/1D	45x14	450	1	004440145
444G/2D	45x18	450	1	004440146
444G/3	50,8	500	1	004440150
444G/4	55x16	560	1	004440155
444G/5A	63,5	620	1	004440163
444G/6	65x18	630	1	004440165

446/C30

assortimento di maschi e filiere,
in acciaio al cromo e accessori
in cassetta di legno



446/C30

1 004460055

≡ 325x220x35 mm - ⚖ 1200 g

430 M mm	440 M mm		
3x0,5	3x0,5	435/1,5	444/1
4x0,7	4x0,7		
5x0,8	5x0,8		
6x1	6x1		
8x1,25	8x1,25		
10x1,5	10x1,5		
12x1,75	12x1,75		

446/C48

assortimento di maschi e filiere,
in acciaio al cromo e accessori
in cassetta di legno



446/C48

1 004460057

≡ 580x300x50 mm - ⚖ 5000 g

430 M mm	440 M mm	440A M mm		
3x0,5	3x0,5	10x1,5	435/1	444/1
4x0,7	4x0,7	12x1,75	435/3	444/2
5x0,8	5x0,8	14x2		
6x1	6x1	16x2		
8x1,25	8x1,25	18x2,5		
10x1,5		20x2,5		
12x1,75				
14x2				
16x2				
18x2,5				
20x2,5				

446/C110

assortimento di maschi e filiere, in acciaio al cromo e accessori per autoriparazione in cassetta di legno



446/C110 1 004460060

500x337x60 mm - 8100 g

430 M mm	433 M mm	440/440A M mm	441/441A M mm
2x0,4	6x0,75	2x0,4	6x0,75
3x0,5	7x0,75	3x0,5	7x0,75
4x0,7	8x0,75	4x0,7	8x0,75
5x0,8	8x1	5x0,8	8x1
6x1	9x0,75	6x1	9x0,75
7x1	9x1	7x1	9x1
8x1,25	10x0,75	8x1,25	10x0,75
9x1,25	10x1	9x1,25	10x1
10x1,5	10x1,25	10x1,5	10x1,25
11x1,5	11x0,75	11x1,5	11x0,75
12x1,75	11x1	12x1,75	11x1
14x2	11x1,25	14x2	11x1,25
16x2	12x0,75	16x2	12x0,75
	12x1		12x1
	12x1,25		12x1,25
	12x1,5		12x1,5
	14x1		14x1
	14x1,25		14x1,25
	14x1,5		14x1,5
	16x1		16x1
	16x1,5		16x1,5
	18x1,5		18x1,5

435/0	444/1	436/1
435/3	444/2	

446ASF/C29

assortimento di maschi e filiere in acciaio al cromo e accessori filettatura **UNF** in cassetta di legno



446ASF/C30 1 004460070

660x410x50 mm - 6000 g

433ASF	440ASF		
1/4	1/4	435/1,5	444/1
5/16	5/16	435/3	444/2
3/8	3/8		444/3
7/16	7/16		
1/2	1/2		
9/16	9/16		
5/8	5/8		
3/4	3/4		

446ASW/C36

assortimento di maschi e filiere in acciaio al cromo e accessori filettatura **Whitworth** in cassetta di legno



446ASW/C37 1 004460075

525x310x50 mm - 3400 g

430ASW	440ASW		
1/8	1/8	435/1,5	444/1
5/32	5/32	435/2	444/2
3/16	3/16		
1/4	1/4		
5/16	5/16		
3/8	3/8		
7/16	7/16		
1/2	1/2		

446ASC/C37

assortimento di maschi e filiere in acciaio al cromo e accessori filettatura **UNC** in cassetta di legno



446ASC/C38 1 004460080

660x410x50 mm - 6700 g

430ASC	440ASC		
1/4	1/4	435/1,5	444/1
5/16	5/16	435/3	444/2
3/8	3/8		444/3
7/16	7/16		
1/2	1/2		
9/16	9/16		
5/8	5/8		
3/4	3/4		

446ASG/C23

assortimento di maschi e filiere in acciaio al cromo e accessori filettatura **GAS** cilindrica in cassetta di legno



446ASG/C24 1 004460085

700x430x70 mm - 9800 g

433ASG	440ASG		
1/8	1/8	435/3	444/2
1/4	1/4	435/5	444/3
3/8	3/8		444/5A
1/2	1/2		
3/4	3/4		
1"	1"		

Beta

ISO 9001

447/C37

assortimento di maschi e filiere
in acciaio HSS e accessori
in cassetta di metallo



447/C37 1 004470055

380x185x35 mm - 3960 g

431 M mm	442 M mm		
3x0,5	3x0,5	435/0	444
4x0,7	4x0,7	435/2	444/0
5x0,8	5x0,8		444/1A
6x1	6x1		444/1B
8x1,25	8x1,25		444/1C
10x1,5	10x1,5		
12x1,75	12x1,75		

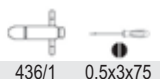

436/1 0,5x3x75

447/C53

assortimento di maschi e filiere
in acciaio HSS e accessori
in cassetta di metallo



447/C53 1 004470060

500x235x50 mm - 9000 g

431 M mm	442 M mm			
3x0,5	3x0,5	435/1,5	444	436/1
4x0,7	4x0,7	435/3	444/0	
5x0,8	5x0,8		444/1A	
6x1	6x1		444/1B	
8x1,25	8x1,25		444/1C	
10x1,5	10x1,5		444/2D	
12x1,75	12x1,75			
14x2	14x2			
16x2	16x2			
18x2,5	18x2,5			
20x2,5	20x2,5			

447/C70

assortimento di maschi e filiere
in acciaio HSS e accessori
per autoriparazione ed industria
in cassetta di legno



447/C70 1 004470065

510x340x70 mm - 7500 g

431 M mm	434 M mm	442 M mm	443 M mm
3x0,5	8x1	3x0,5	8x1
4x0,7	10x1,25	4x0,7	10x1,25
5x0,8	12x1,25	5x0,8	12x1,25
6x1	12x1,5	6x1	12x1,5
7x1	14x1,25	7x1	14x1,25
8x1,25	14x1,5	8x1,25	14x1,5
10x1,5	16x1,5	10x1,5	16x1,5
12x1,75	12x1,75	12x1,75	
14x2	14x2		
16x2	16x2		

435/0	444	436/1
435/3	444/0	
	444/1A	
	444/1B	
	444/1C	
	444/1D	

450

seghe a tazza
in acciaio HSS-Bimetal



Ø 16÷30 = 450AL/1

Ø 32÷152 = 450AL/2

Ø mm	Ø "	A mm	
16	(5/8)	57	1 004500016
17	(11/16)	57	1 004500017
19	(3/4)	51	1 004500019
20	-	51	1 004500020
21	(13/16)	51	1 004500021
22	(7/8)	51	1 004500022
24	(15/16)	51	1 004500024
25	(1")	51	1 004500025
27	(1"1/16)	51	1 004500027
29	(1"1/8)	51	1 004500029
30	(1"3/16)	51	1 004500030
32	(1"1/4)	51	1 004500032
33	(1"5/16)	51	1 004500033
35	(1"3/8)	51	1 004500035

Ø mm	Ø "	A mm	
37	(1"7/16)	51	1 004500037
38	(1"1/2)	44	1 004500038
40	(1"9/16)	44	1 004500040
41	(1"5/8)	44	1 004500041
43	(1"11/16)	44	1 004500043
44	(1"3/4)	44	1 004500044
46	(1"13/16)	44	1 004500046
48	(1"7/8)	44	1 004500048
51	(2")	44	1 004500051
52	(2"1/16)	44	1 004500052
54	(2"1/8)	44	1 004500054
57	(2"1/4)	44	1 004500057
59	(2"5/16)	44	1 004500059
60	(2"3/8)	44	1 004500060
64	(2"1/2)	44	1 004500064
65	(2"9/16)	44	1 004500065
67	(2"5/8)	44	1 004500067
68	-	44	1 004500068
70	(2"3/4)	44	1 004500070
73	(2"7/8)	44	1 004500073
76	(3")	44	1 004500076
79	(3"1/8)	44	1 004500079
83	(3"1/4)	44	1 004500083
86	(3"3/8)	44	1 004500086
89	(3"1/2)	44	1 004500089
92	(3"5/8)	44	1 004500092
95	(3"3/4)	44	1 004500095
98	(3"7/8)	44	1 004500098
102	(4")	44	1 004500102
105	(4"1/8)	44	1 004500105
108	(4"1/4)	44	1 004500108
111	(4"3/8)	44	1 004500111
114	(4"1/2)	44	1 004500114
121	(4"3/4)	44	1 004500121
127	(5")	44	1 004500127
140	(5"1/2)	44	1 004500140
152	(6")	44	1 004500152

450AL

alberi per seghe a tazza



	Ø mm	L mm	
450AL/1	16÷30	54	1 004500210
450AL/2	32÷152	70	1 004500215

Beta
SHOP
in Shop

450AD

adattatore per alberi 450AL/1



450AD	∅ mm	32÷51	1	004500230
-------	---------	-------	---	-----------

450PA/1

punta per centrare
in acciaio HSS
per alberi 450AL/1



450PA/1	∅xL mm	6,35x105	1	004500252
---------	-----------	----------	---	-----------

450PA/2

punta per centrare
in acciaio HSS
per alberi 450AL/2



450PA/2	∅xL mm	6,35x90	1	004500253
---------	-----------	---------	---	-----------

450PR

prolunga per seghe a tazza



450PR	L mm	305	1	004500255
-------	---------	-----	---	-----------

450/C9

assortimento di seghe a tazza
ed accessori per **elettricisti**



450/C9	1	004500305
--------	---	-----------

450 ∅ 22 - 29 - 35 - 44 - 51 - 64 mm

450AL /1 - /2

450AD

220x160x60 mm - 1120 g

450/C13

assortimento di seghe a tazza
ed accessori per **installatori**



450/C13	1	004500310
---------	---	-----------

450 ∅ 19 - 22 - 29 - 35 - 38
44 - 51 - 57 - 64 mm

450AL /1 - /2

450PA/1

450AD

215x180x65 mm - 1435 g

450/C21

assortimento di seghe a tazza
ed accessori per **uso industriale**



450/C21	1	004500315
---------	---	-----------

450 ∅ 19 - 22 - 29 - 35 - 38
44 - 51 - 57 - 64 - 76
83 - 92 - 95 - 105 - 114 mm

450AL /1 - /2

450PA

450PR

450AD

420x280x60 mm - 5200 g

451

frese a tazza
in acciaio HSS
interamente rettificate

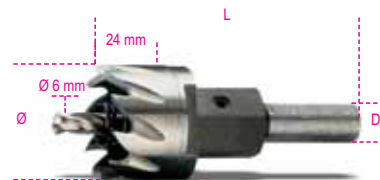

∅ mm	L mm	D		
12	85	8	1	004510012
13	85	8	1	004510013
14	85	8	1	004510014
15	85	10	1	004510015
16	85	10	1	004510016
17	85	10	1	004510017
18	85	10	1	004510018
19	85	10	1	004510019
20	85	10	1	004510020
21	85	10	1	004510021
22	85	10	1	004510022
23	85	10	1	004510023
24	85	10	1	004510024
25	85	10	1	004510025
26	90	10	1	004510026
27	90	10	1	004510027
28	90	10	1	004510028
29	90	10	1	004510029
30	90	10	1	004510030
31	90	10	1	004510031
32	90	10	1	004510032
33	90	10	1	004510033
34	90	10	1	004510034
35	90	10	1	004510035
36	85	10	1	004510036
37	85	10	1	004510037
38	85	10	1	004510038
39	85	10	1	004510039
40	85	10	1	004510040
41	85	10	1	004510041
42	85	10	1	004510042
43	85	10	1	004510043
44	85	10	1	004510044
45	85	10	1	004510045
46	85	10	1	004510046
47	85	10	1	004510047
48	85	10	1	004510048
49	85	10	1	004510049
50	85	10	1	004510050

451GA

gambi per frese a tazza 451



M	∅ mm	L mm	D mm		
10x1,25	12÷14	57	8	1	004510101
12x1,25	15÷34	57	10	1	004510102
14x1,5	35÷50	57	10	1	004510105

451PA

punta pilota per frese a tazza 451
in acciaio HSS



451PA	∅ mm	L mm	1	004510103
	6	53		



451PR

prolunga per frese a tazza 451



M mm	Ø mm	L mm		
12x1,25	15÷34	400	1	004510104
14x1,5	35÷50	400	1	004510108

452

frese a tazza
con inserti in metallo duro



Ø mm	Ø1 mm	L mm		
15	10	90	1	004520015
16	10	90	1	004520016
17	10	90	1	004520017
18	10	90	1	004520018
19	10	90	1	004520019
20	10	90	1	004520020
21	10	95	1	004520021
22	10	95	1	004520022
23	10	95	1	004520023
24	10	95	1	004520024
25	10	95	1	004520025
26	10	95	1	004520026
27	10	95	1	004520027
28	10	95	1	004520028
29	10	95	1	004520029
30	10	95	1	004520030
31	10	95	1	004520031
32	10	95	1	004520032
33	10	95	1	004520033
34	10	95	1	004520034
35	10	95	1	004520035
36	10	95	1	004520036
37	10	95	1	004520037
38	10	95	1	004520038
39	13	95	1	004520039
40	13	95	1	004520040
41	13	95	1	004520041
42	13	95	1	004520042
43	13	95	1	004520043
44	13	95	1	004520044
45	13	95	1	004520045
46	13	95	1	004520046
47	13	95	1	004520047
48	13	95	1	004520048
49	13	95	1	004520049
50	13	90	1	004520050
55	13	90	1	004520055
60	13	90	1	004520060
65	13	90	1	004520065
70	13	95	1	004520070
75	13	95	1	004520075
80	13	95	1	004520080
85	13	95	1	004520085
90	13	95	1	004520090

452GA

gambi per frese a tazza 452



	Ø mm		
452GA/1	15÷21	1	004520125
452GA/2	22÷38	1	004520126
452GA/3	39÷100	1	004520127

560/C2

moltiplicatore di coppia e accessori
rapporto 5:1
in cassetta di plastica

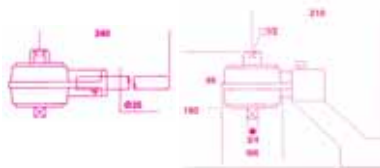

Nm	Kgfm	lbf.ft	□	■	kg
1300	130	960	1/2	3/4	3,8

560/C2	1	005600020
560/2	1	005600002
560/18	1	005600018
560/19	1	005600019
560/22	1	005600022

560/C4+

moltiplicatore di coppia
rapporto 5:1
con piede di reazione

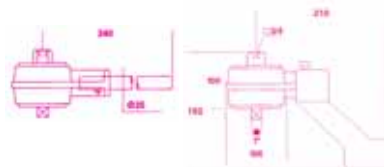

Nm	Kgfm	lbf.ft	□	■	kg
2700	270	2000	3/4	1"	5

560/C4+	1	005600042
560/4	1	005600004
560/18	1	005600018
560/22	1	005600022

561

moltiplicatore di coppia
rapporto 5:1



Nm	Kgfm	lbf.ft	□	■	kg
1000	100	740	1/2	3/4	4,6

561	1	005610001
-----	---	-----------

562/1 - 562/2

moltiplicatori di coppia
rapporto 5:1



Nm	Kgfm	lbf.ft	□	■	D mm	A mm	L min mm	L max mm	kg
1700	170	1250	3/4	1"	108	95	85	220	5,3

562/1	1	005620001
-------	---	-----------

Nm	Kgfm	lbf.ft	□	■	D mm	A mm	L min mm	L max mm	kg
3400	340	2500	3/4	1"	119	115	85	265	7,0

562/2	1	005620002
-------	---	-----------

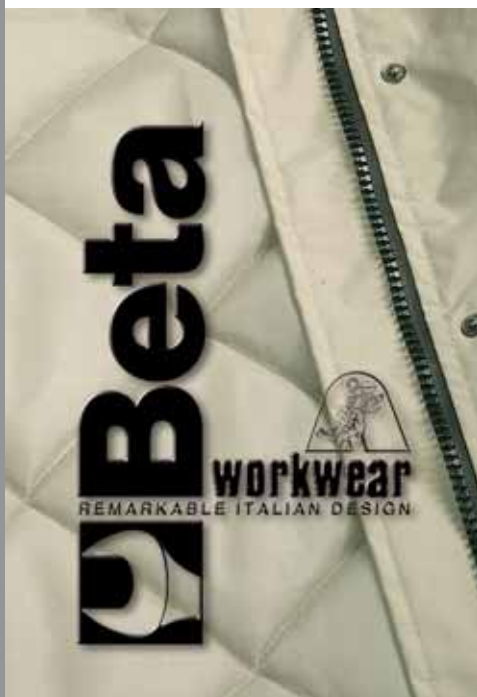

564/3R - 564/4R

moltiplicatori di coppia
rapporto 25:1
con dispositivo antiritorno



Nm	Kgfm	lbf.ft	□	■	D mm	A mm	L mm	kg
3000	300	2200	1/2	1"	108	188	155	9,2

564/3R 1 005640003

Nm	Kgfm	lbf.ft	□	■	D mm	A mm	L mm	kg
6000	600	4500	1/2	1 1/2"	119	235	200	15,5

564/4R 1 005640004

565/1R - 565/2R - 565/3R

moltiplicatori di coppia
rapporto 25:1
con dispositivo antiritorno



Nm	Kgfm	lbf.ft	□	■	D mm	A mm	L min mm	L max mm	kg
1700	170	1250	1/2	1"	108	125	80	215	7,7

565/1R 1 005650011

Nm	Kgfm	lbf.ft	□	■	D mm	A mm	L min mm	L max mm	kg
3400	340	2500	1/2	1"	119	145	85	265	10,1

565/2R 1 005650012

Nm	Kgfm	lbf.ft	□	■	D mm	A mm	L min mm	L max mm	kg
3400	340	2500	1/2	1 1/2"	119	145	85	265	10,7

565/3R 1 005650013



565/4R

moltiplicatori di coppia
rapporto 25:1
con dispositivo antiritorno

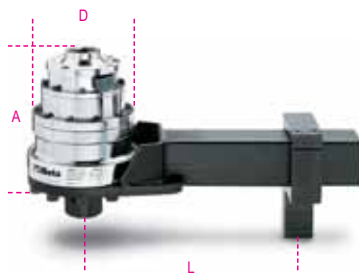

Nm	Kgfm	lbf.ft	□	■	D mm	A mm	L min mm	L max mm	kg
6000	600	4500	1/2	1 1/2"	144	180	125	335	17

565/4R 1 005650014

565/5R

moltiplicatori di coppia
rapporto 25:1
con dispositivo antiritorno

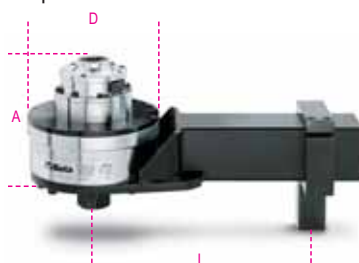

Nm	Kgfm	lbf.ft	□	■	D mm	A mm	L min mm	L max mm	kg
9500	950	7000	3/4	1 1/2"	184	180	155	355	25

565/5R 1 005650015

567/4R

moltiplicatori di coppia
rapporto 125:1
con dispositivo antiritorno

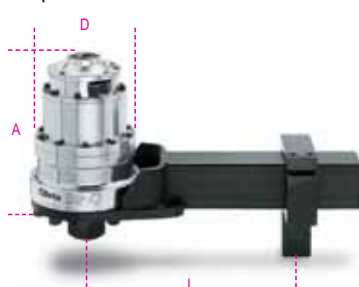

Nm	Kgfm	lbf.ft	□	■	D mm	A mm	L min mm	L max mm	kg
6000	600	4500	1/2	1 1/2"	144	210	125	335	19

567/4R 1 005670014

567/5R

moltiplicatore di coppia
rapporto 125:1
con dispositivo antiritorno

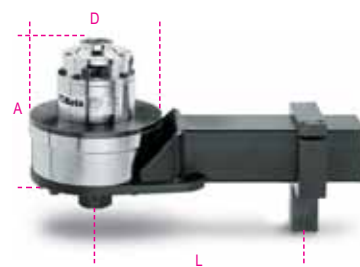

Nm	Kgfm	lbf.ft	□	■	D mm	A mm	L min mm	L max mm	kg
9500	950	7000	1/2	1 1/2"	184	210	155	350	27

567/5R 1 005670015

580/5F - 580/10F

giravite dinamometrici a lettura
adatti a serraggi destrorsi e sinistrorsi
precisione di serraggio ± 6%

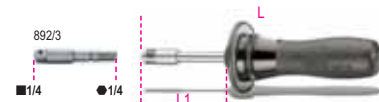

UNI EN 26789
ISO 6789

cNm	gfm	ozf.in	○	L mm	L1 mm	g
0÷50	0÷50	0÷70	1/4	180	66	190

580/5F 1 005800205

cNm	gfm	ozf.in	○	L mm	L1 mm	g
0÷100	0÷100	0÷140	1/4	180	66	190

580/10F 1 005800210

580/25F - 580/50F

giravite dinamometrici a lettura
adatti a serraggi destrorsi e sinistrorsi
precisione di serraggio ± 6%

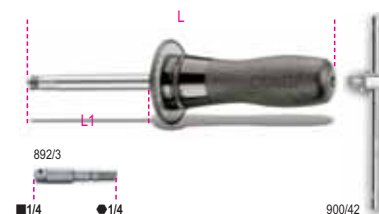

UNI EN 26789
ISO 6789

cNm	gfm	lbf.in	○	L mm	L1 mm	g
0÷250	0÷250	0÷20	1/4	250	110	450

580/25F 1 005800225

cNm	gfm	lbf.in	○	L mm	L1 mm	g
0÷500	0÷500	0÷40	1/4	250	110	460

580/50F 1 005800250



581/1F

giravite dinamometrico a slittamento, non graduato
adatto a serraggi destrorsi e sinistrorsi
precisione di serraggio $\pm 6\%$
(per il settaggio della coppia usare gli artt. 588 - 682)



UNI EN 26789
ISO 6789

Nm	gfm	Ø	L mm	L1 mm	g
0,6÷5,5	60÷550	1/4	138	21	275

581/1F 1 005810010

582F0 - 582F1

giravite dinamometrico a slittamento
adatto a serraggi destrorsi e sinistrorsi,
precisione di serraggio $\pm 6\%$



UNI EN 26789
ISO 6789

cNm	gfm	Ø	L mm	L1 mm	g
5÷40	5÷40	1/4	164	32	160

582F0 1 005820000

cNm	gfm	Ø	L mm	L1 mm	g
20÷120	20÷120	1/4	180	32	215

582F1 1 005820001

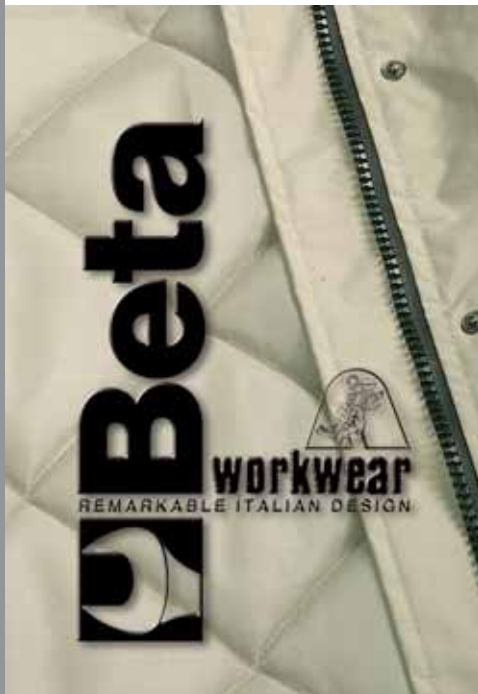

584F6 - 584F9

giravite dinamometrici a slittamento
adatti a serraggi destrorsi e sinistrorsi,
precisione di serraggio $\pm 6\%$

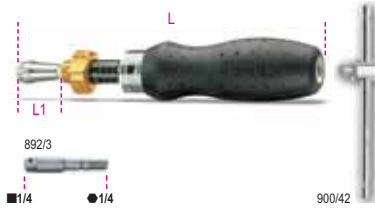

UNI EN 26789
ISO 6789

Nm	gfm	Ø	L mm	L1 mm	g
1÷6	100÷600	1/4	195	32	365

584F6 1 005840001

Nm	gfm	Ø	L mm	L1 mm	g
4÷9	400÷900	1/4	195	32	365

584F9 1 005840002

588

misuratori di coppia
meccanici analogici



Nm	Ø	□	lbf.in	kg
0,2÷4	1/4	3/8	2÷36	1,9

588/4 1 005880104

Nm	Ø	□	lbf.in	kg
2÷25	1/4	3/8	20÷240	2,0

588/25 1 005880125

590 + 592/4

chiavi dinamometriche a lettura diretta
adatte a serraggi destrorsi e sinistrorsi
precisione di serraggio $\pm 4\%$



UNI EN 26789
ISO 6789

Nm	Kgfm	lbf.in	□	A mm	L mm	kg
0,3÷4	0,03÷0,4	3÷35	1/4	60	253	0,52

590 1 005900001

Nm	Kgfm	lbf.in	□	A mm	L mm	kg
0,5÷13,5	0,05÷1,35	4÷120	1/4	60	253	0,52

590/1 1 005900003

Nm	Kgfm	lbf.in	□	A mm	L mm	kg
1÷27	0,1÷2,7	10÷240	3/8	70	253	0,52

592/3 1 005920005

Nm	Kgfm	lbf.in	□	A mm	L mm	kg
3÷40	0,3÷4	20÷360	3/8	70	253	0,52

592/4 1 005920007



594/8 - 594/21

chiavi dinamometriche a lettura diretta
adatte a serraggi destrorsi e sinistrorsi
precisione di serraggio $\pm 4\%$



UNI EN 26789
ISO 6789

Nm	Kgfm	lbf.ft	□	A mm	L mm	kg
6÷80	0,6÷8	5÷60	1/2	85	455	1,35

594/8 1 005940011

Nm	Kgfm	lbf.ft	□	A mm	L mm	kg
20÷215	2÷21,5	15÷160	1/2	85	530	1,40

594/21 1 005940015

596/80SL - 598/200SL

chiavi dinamometriche a lettura diretta adatte a serraggi destrorsi e sinistrorsi precisione di serraggio $\pm 4\%$

Il raggiungimento della coppia prefissata viene segnalato da una luce e da un suono intermittente



UNI EN 26789
ISO 6789

Nm	Kgfm	lbf.ft	■	A mm	L mm	g
40÷800	4÷80	20÷600	3/4	115	1025	4,85

596/80SL	1	005960020
----------	---	-----------

Nm	Kgfm	lbf.ft	■	A mm	L mm	g
200÷2000	20÷200	150÷1500	1"	135	1930	16,70

598/200SL	1	005980022
-----------	---	-----------

599DGT/20

chiave dinamometrica elettronica con cricchetto reversibile, per serraggi destrorsi e sinistrorsi precisione di serraggio $\pm 2\%$ destrorso, $\pm 3\%$ sinistrorso

il raggiungimento della coppia prefissata viene segnalato da avvisori luminosi e da un suono intermittente

• Alimentazione con 2 batterie da 1,5V (include)

12"

CE



UNI EN 26789
ISO 6789

Nm	Kgfm	lbf.ft	■	D mm	A mm	L mm	g
40÷200	4÷20	30÷150	1/2	40	43	520	2

599DGT/20	1	005990020
-----------	---	-----------

600/1 - 600/2

attrezzi per serraggi angolari



	□	■	☐	☑
600/1	1/2	1/2		1 006000001
600/2	3/4	3/4		1 006000002

601

goniometro elettronico per serraggi angolari

il raggiungimento dell'angolo prefissato viene segnalato da avvisori luminosi e da un suono intermittente

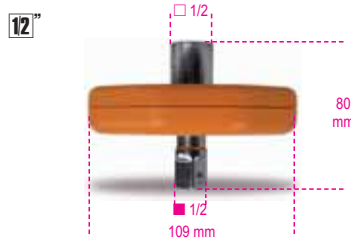

FUNZIONI:

- Lettura diretta dell'angolo
- Impostazione angolo da raggiungere
- Valore massimo raggiunto

DATI TECNICI:

- Campo di misura: da -999° a $+999^\circ$
- Precisione: $\pm 1\%$
- Lettura: destrorsa/sinistrorsa
- Alimentazione: 3 batterie 1,5V (include)
- Risoluzione: $0,1^\circ$
- Display: 32 digit - tipo LCD - retroilluminato

601	1	006010001
-----	---	-----------

603/5 - 603/10

chiavi dinamometriche a slittamento per serraggi destrorsi precisione di serraggio $\pm 6\%$



ISO 6789

Nm	Kgfm	lbf.in	■	A mm	L mm	g
1÷5	0,1÷0,5	10÷45	1/4	35	195	235

603/5	1	006030005
-------	---	-----------

Nm	Kgfm	lbf.in	■	A mm	L mm	g
2÷10	0,2÷1,0	18÷90	1/4	35	195	235

603/10	1	006030010
--------	---	-----------

606/2 - 606/2X

chiavi dinamometriche a scatto con cricchetto reversibile per serraggi destrorsi precisione di serraggio $\pm 4\%$

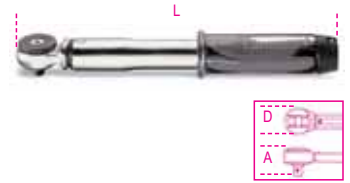

UNI EN 26789
ISO 6789

Nm	Kgfm	lbf.in	■	D mm	A mm	L mm	g
4÷20	0,4÷2	40÷180	1/4	28	25	220	400

606/2	1	006060102
-------	---	-----------

Nm	Kgfm	lbf.in	■	D mm	A mm	L mm	g
4÷20	0,4÷2	40÷180	3/8	28	31	220	400

606/2X	1	006060103
--------	---	-----------

606/6 + 606/30

chiavi dinamometriche a scatto con cricchetto reversibile per serraggi destrorsi precisione di serraggio $\pm 4\%$



UNI EN 26789
ISO 6789

Nm	Kgfm	lbf.ft	■	D mm	A mm	L mm	g
8÷60	0,8÷6	6÷44	3/8	30	33	305	595

606/6	1	006060105
-------	---	-----------

Nm	Kgfm	lbf.ft	■	D mm	A mm	L mm	g
20÷100	2÷10	15÷80	3/8	30	33	345	660

606/10	1	006060110
--------	---	-----------

Nm	Kgfm	lbf.ft	■	D mm	A mm	L mm	g
20÷100	2÷10	15÷80	1/2	30	37	345	680

606/10X	1	006060111
---------	---	-----------

Nm	Kgfm	lbf.ft	■	D mm	A mm	L mm	g
40÷200	4÷20	30÷150	1/2	40	43	440	920

606/20	1	006060120
--------	---	-----------

Nm	Kgfm	lbf.ft	■	D mm	A mm	L mm	g
60÷330	6÷33	40÷250	1/2	40	43	560	1180

606/30	1	006060130
--------	---	-----------



606MQ/50

chiave dinamometrica a scatto con cricchetto reversibile



EN 60900
UNI EN 26789
ISO 6789

Nm	Kgfm	lbf.ft	A mm	L mm	g
5÷50	0,5÷5	4÷40	90	375	1130

606MQ/50 1 006060705

608/2

barra dinamometrica a scatto per serraggi destrorsi e sinistrorsi precisione di serraggio ± 4%



UNI EN 26789
ISO 6789

Nm	Kgfm	lbf.in	Ø mm	L mm	g
4÷20	0,4÷2	40÷180	16	208	330

608/2 1 006080102

612 + 614

cricchetti reversibili per barre dinamometriche



Gli articoli 612 e 612X non devono essere utilizzati con coppie di serraggio superiori a 100 Nm

	■	L mm	
612	3/8	66	3 006120000
612X	1/2	66	3 006120010
614	1/2	71	3 006140000
614X	3/4	71	3 006140004

614/50

cricchetto semplice per barre dinamometriche



	■	L mm	
614/50	1/2	71	3 006140002

Meccanismi rotanti di ricambio dei cricchetti, vedi tabella dopo l'art. 929/C8

616 - 617 - 619

quadri maschi per barre dinamometriche



	■	L mm	
616	1/4	61	3 006160000
617	3/8	61	3 006170000
619	1/2	63	3 006190000

642

chiavi a forchetta per barre dinamometriche



Ø mm	L mm	
10	57	2 006420010
12	58	2 006420012
13	58	2 006420013
14	59	2 006420014
17	60	2 006420017
19	61	2 006420019

652

chiavi poligonali per barre dinamometriche



Ø mm	L mm	
10	59	2 006520010
13	61	2 006520013
14	62	2 006520014
17	64	2 006520017
19	65	2 006520019

666

chiavi dinamometriche a scatto con cricchetto reversibile per serraggi destrorsi precisione di serraggio ± 4%



UNI EN 26789
ISO 6789

Nm	Kgfm	lbf.ft	■	D mm	A mm	L mm	g
8÷60	0,8÷6	6÷44	3/8	30	33	305	600

666/6 1 006660106

Nm	Kgfm	lbf.ft	■	D mm	A mm	L mm	g
20÷100	2÷10	15÷80	3/8	30	33	345	680

666/10 1 006660110

Nm	Kgfm	lbf.ft	■	D mm	A mm	L mm	g
20÷100	2÷10	15÷80	1/2	30	37	350	780

666/10X 1 006660111

Nm	Kgfm	lbf.ft	■	D mm	A mm	L mm	g
40÷200	4÷20	30÷150	1/2	40	43	440	995

666/20 1 006660120

Nm	Kgfm	lbf.ft	■	D mm	A mm	L mm	g
60÷330	6÷33	40÷250	1/2	40	43	560	1260

666/30 1 006660130

667

chiavi dinamometriche a scatto con cricchetto semplice per serraggi destrorsi e sinistrorsi precisione di serraggio ± 4%



UNI EN 26789
ISO 6789

Nm	Kgfm	lbf.ft	■	D mm	A mm	L mm	g
40÷200	4÷20	30÷150	1/2	40	43	440	960

667/20 1 006670120

Nm	Kgfm	lbf.ft	■	D mm	A mm	L mm	g
60÷330	6÷33	40÷250	1/2	40	43	560	1260

667/30 1 006670130

Nm	Kgfm	lbf.ft	■	D mm	A mm	L mm	g
80÷400	8÷40	60÷320	3/4	50	50	690	2200

667/40 1 006670140

Beta
Collection

667/C3

assortimento di una chiave dinamometrica a scatto con cricchetto semplice 667/40 e tre chiavi a bussola esagonali



667/C3 3/4 1 006670240
Nm 80÷400

667/40
928A 24-27-30 mm

**Meccanismi rotanti
di ricambio dei cricchetti,
vedi tabella dopo l'art. 929/C8**

668

barre dinamometriche a scatto per serraggi destrorsi e sinistrorsi precisione di serraggio ± 4%



UNI EN 26789
ISO 6789

Nm	Kgfm	lbf.ft	Ø mm	L mm	g
8÷60	0,8÷6	6÷44	16	300	530

668/5 1 006680105

Nm	Kgfm	lbf.ft	Ø mm	L mm	g
20÷100	2÷10	15÷80	16	340	610

668/10 1 006680110

Nm	Kgfm	lbf.ft	Ø mm	L mm	g
40÷200	4÷20	30÷150	16	420	780

668/20 1 006680120

Nm	Kgfm	lbf.ft	Ø mm	L mm	g
60÷300	6÷30	40÷220	16	550	1100

668/30 1 006680130

671/C10

barra dinamometrica 668/10 e accessori

3/8"



671/C10 1 006710010

668/10	100 Nm
612	■ 3/8
617	■ 3/8
642	10-13-14-17-19 mm
652	10-13-14-17-19 mm
910A	□ 3/8-8-10-11-13-14-17-19 mm
910/21	125 mm
910/22	250 mm

620x180x45 mm - 4300 g



671/C20

barra dinamometrica 668/20 e accessori

1/2"



671/C20 1 006710020

668/20	200 Nm
614	■ 1/2
619	■ 1/2
642	10-13-14-17-19 mm
652	10-13-14-17-19 mm
920A	□ 1/2-10-11-13-14-17-19-22 mm
920/20	75 mm
920/21	125 mm
920/22	255 mm

510x180x45 mm - 5500 g

671/C30

barra dinamometrica 668/30 e accessori

1/2"



671/C30 1 006710030

668/30	300 Nm
614	■ 1/2
619	■ 1/2
642	13-14-17-19 mm
652	13-14-17-19 mm
920A	□ 1/2-13-14-17-19-22-24-27 mm
920/20	75 mm
920/21	125 mm
920/22	255 mm

620x180x45 mm - 5800 g

677

chiavi dinamometriche a disinnesto con cricchetto semplice per serraggi destrorsi e sinistrorsi precisione di serraggio ± 4%

3/4"



UNI EN 26789
ISO 6789

Nm	Kgfm	lbf.ft	D mm	A mm	L mm	kg
100÷500	10÷50	70÷350	70	55	915	5,2

677/50 1 006770050

Nm	Kgfm	lbf.ft	D mm	A mm	L mm	kg
150÷700	15÷70	100÷500	70	55	1140	6,2

677/70 1 006770070

Nm	Kgfm	lbf.ft	D mm	A mm	L mm	kg
300÷1000	30÷100	200÷750	70	55	1470	7,5

677/100 1 006770100

677/C...

chiavi dinamometriche 677 in cassetta

3/4"



677/C50 1 006770605

Nm 100÷500

677/C70 1 006770610

Nm 150÷700

677/C100 1 006770615

Nm 300÷1000

Beta

ISO 9001

678

chiavi dinamometriche a scatto con cricchetto semplice per serraggi destrorsi e sinistrorsi precisione di serraggio $\pm 4\%$

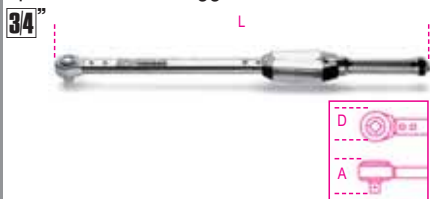

UNI EN 26789
ISO 6789

Nm	Kgfm	lbf.ft	D mm	A mm	L mm	kg
110÷550	11÷55	80÷405	61	55	845	3,7

678/55 1 006780055

Nm	Kgfm	lbf.ft	D mm	A mm	L mm	kg
300÷1000	30÷100	220÷750	75	60	1250	6,0

678/100 1 006780100

Nm	Kgfm	lbf.ft	D mm	A mm	L mm	kg
500÷1500	50÷150	370÷1100	75	60	1570	6,7

678/150 1 006780150

678/C...

chiavi dinamometriche 678 in cassetta



678/C55 1 006780605

Nm 110÷550

678/C100 1 006780610

Nm 300÷1000

678/C150 1 006780615

Nm 500÷1500

678/CV...

cassette vuote per chiavi dinamometriche 677 e 678



678/CV1 1 006780405

677/50-678/55

678/CV2 1 006780410

677/70-678/100

678/CV3 1 006780415

677/100-678/150

680/40

misuratore di coppia elettronico digitale Dynatester 680 per verifica tarature funzionamento destrorso e sinistrorso



680/40 Nm 16÷400 1 006800040

682

misuratore di coppia elettronico digitale con trasduttori porziometrici Dynatester 682 funzionamento destrorso e sinistrorso

Alta precisione di lettura
Fornito di uscita seriale RS 232



CARATTERISTICHE TECNICHE:

Precisione di lettura: $\pm 1\%$ del valore letto

Unità di misura selezionabili

Nm-dNm-cNm-Lbf.ft-Lbf.in-Ozf.in-Kgf.m-Kgf.cm-gf.cm

Alimentazione: 90 a 264V AC a 50/60 Hz

Dimensioni: 235x185x185 mm

Verifica di tolleranza secondo norma ISO6789

Indicazione dell'intervallo di accettabilità specifico per ogni chiave dinamometrica testata

Display: Menu selezionabile in 11 lingue

Documentazione allegata

Certificato di calibrazione con rintracciabilità UKAS

	Nm		
682/60	1,2÷60	1	006820006
682/400	8÷400	1	006820040
682/1500	30÷1500	1	006820150

700

chiavi a bussola Macchina serie normale



UNI/ISO 2725 DIN 3129

mm	D mm		
4	7,8	10	007000040
4,5	7,9	10	007000045
5	9,0	10	007000050
5,5	9,6	10	007000055
6	10,2	10	007000060
7	11,5	10	007000070
8	13,7	10	007000080
9	14,0	10	007000090
10	15,2	10	007000100
11	16,5	10	007000110
12	17,7	10	007000120
13	19,0	10	007000130
14	20,2	10	007000140

700FTX

chiavi a bussola Macchina per viti con testa a profilo Torx®



	D mm		
E5	7,7	2	007000405
E6	8,7	2	007000406
E7	9,2	2	007000407
E8	9,7	2	007000408
E10	12,2	2	007000410

700/16

raccordo Macchina con attacco quadro femmina 1/4" e maschio 3/8"



	1/4	3/8	L mm		
700/16			22	5	007000814

700/20

prolunga Macchina con attacchi quadri maschio e femmina 1/4"



	L mm		
700/20	75	2	007000821

700/25

snodo Macchina con attacchi quadri maschio e femmina 1/4"



	L mm		
700/25	39	2	007000830

700/OR - 700/SP

anello e spina per bussole e accessori Macchina

14"



700/OR	10	007000920
700/SP	10	007000910

702FTX/C7

cassetta bussole per motori DEUTZ

14"

38"

12"



702FTX/C7	1	007020400
-----------	---	-----------

	700FTX	E8 - E10
	710FTX	E10 - E12
	720FTX	E18
	95FTX	E6xE8 - E10xE12

170x100x35 mm - 800 g

710

chiavi a bussola Macchina serie normale

38"



UNI/ISO 2725 DIN 3129

mm	D mm	L mm	
7	12,5	28	5 007100007
8	13,8	28	5 007100008
9	15,0	28	5 007100009
10	16,3	28	5 007100010
11	17,5	30	5 007100011
12	19,0	30	5 007100012
13	20,0	30	5 007100013
14	21,3	30	5 007100014
16	23,8	30	5 007100016
17	25,0	30	5 007100017
18	26,3	30	5 007100018
19	27,5	30	5 007100019
21	30,0	32	5 007100021
22	32,0	32	5 007100022

710FTX

chiavi a bussola Macchina per viti con testa a profilo Torx®

38"



	D mm	
E5	8,0	5 007100405
E6	9,0	5 007100406
E7	10,0	5 007100407
E8	11,5	5 007100408
E10	14,0	5 007100410
E12	15,9	5 007100412
E14	17,7	5 007100414

710/16

raccordo Macchina con attacco quadro femmina 3/8" e maschio 1/2"

38"



710/16	3/8	1/2	32	3	007100810
--------	-----	-----	----	---	-----------

710/20

prolunga Macchina con attacchi quadri maschio e femmina 3/8"

38"



710/20	L mm	75	3	007100821
--------	------	----	---	-----------

710/21

prolunga Macchina con attacchi quadri maschio e femmina 3/8"

38"



710/21	L mm	125	3	007100823
--------	------	-----	---	-----------

710/25

snodo Macchina con attacchi quadri maschio e femmina 3/8"

38"



710/25	L mm	58	2	007100830
--------	------	----	---	-----------

710/C10

10 chiavi a bussola Macchina

38"



710/C10	1	007100910
7-8-10-11-12-13		
14-17-19-22 mm		

130x55x40 mm - 800 g

710/OR... - 710/SP...

anelli e spine per bussole e accessori Macchina

38"



710/OR1	10	007100921
710/OR2	10	007100922
710/SP1	10	007100911
710/SP2	10	007100912

720

chiavi a bussola Macchina serie normale

12"



UNI/ISO 2725 DIN 3129

mm	D mm	L mm	
10	17,0	38	5 007200010
11	18,5	38	5 007200011
12	20,0	38	5 007200012
13	21,0	38	5 007200013
14	22,5	38	5 007200014
15	23,0	38	5 007200015
16	25,0	38	5 007200016
17	26,0	38	5 007200017
18	27,5	38	5 007200018
19	28,5	38	5 007200019
21	31,0	38	5 007200021
22	32,5	38	5 007200022
23	34,0	38	5 007200023
24	35,0	38	5 007200024
27	38,5	45	3 007200027
30	42,0	50	3 007200030
32	44,0	50	3 007200032
36	50,0	50	3 007200036

Beta



720AS

chiavi a bussola Macchina serie normale



mm	D mm	L mm		
3/8	17,0	38	3	007200210
7/16	18,2	38	3	007200211
1/2	20,7	38	3	007200213
9/16	22,0	38	3	007200214
5/8	24,5	38	3	007200216
11/16	25,7	38	3	007200217
3/4	28,2	38	3	007200219
13/16	30,7	38	3	007200221
7/8	32,0	38	3	007200222
15/16	34,5	38	3	007200224
1	35,7	38	3	007200225
1.1/16	38,2	40	3	007200227
1.1/8	40,7	42	3	007200229
1.1/4	44,5	42	3	007200232

720L

chiavi a bussola Macchina serie lunga



UNI/ISO 2725

mm	D mm	D1 mm		
10	17,0	25	3	007200310
11	18,5	25	3	007200311
12	20,0	25	3	007200312
13	21,0	25	3	007200313
14	22,5	25	3	007200314
15	23,0	30	3	007200315
16	25,0	30	3	007200316
17	26,0	30	3	007200317
18	27,5	30	3	007200318
19	28,5	30	3	007200319
21	31,0	30	3	007200321
22	32,5	30	3	007200322
24	35,0	30	3	007200324
27	38,5	30	3	007200327
30	42,0	30	2	007200330
32	44,0	30	2	007200332
36	50,0	30	2	007200336

720L/S3

serie di 3 chiavi a bussola 720L



mm		
17-19-21	1	007200355

720PL

chiavi a bussola Macchina con inserti polimerici per dadi ruote



mm	D mm		
17	29,5	2	007200617
19	29,5	2	007200619
21	31,0	2	007200621
22	33,0	2	007200622
24	35,0	2	007200624

720PL/C5

5 chiavi a bussola Macchina con inserti polimerici per dadi ruote



720PL/C5	
17-19-21-22-24 mm	1 007200650

240x165x50 mm - 1,8 kg

720LPL

chiavi a bussola Macchina con inserti polimerici per dadi ruote serie lunga



mm	D mm		
17	24,3	1	007200717
19	26,2	1	007200719
21	28,5	1	007200721

720LPL/C3

3 chiavi a bussola Macchina lunghe con inserti polimerici per dadi ruote fornito con 3 inserti di ricambio



720LPL/C3	
17-19-21 mm	1 007200750

270x185x60 mm - 1 kg

720IP

inserti di ricambio polimerici per chiavi a bussola 720PL-LPL



720IP17	1	007200667
720IP19	1	007200669
720IP21	1	007200671
720IP22	1	007200672
720IP24	1	007200674

720FTX

chiavi a bussola Macchina per viti con testa a profilo Torx®



	D mm	L mm		
E10	14,0	38	3	007200410
E12	15,9	38	3	007200412
E14	17,7	38	3	007200414
E16	20,0	38	3	007200416
E18	22,0	38	3	007200418
E20	25,0	40	3	007200420



720FTX/SB6	
E10-E12-E14 E16-E18-E20	1 007200450

720TX

chiavi a bussola maschio Macchina per viti con impronta Torx®



	L mm		
T30	60	3	007200460
T40	60	3	007200470
T45	68	3	007200472
T50	68	3	007200474
T55	68	3	007200476
T60	68	3	007200478

Beta
SHOP
in Shop

720TX/C6

6 chiavi a bussola maschio Macchina per viti con impronta Torx®



720TX/C6
T30-T40-T45
T50-T55-T60

250x100x35 mm - 850 g

720ME

chiavi a bussola Macchina maschio esagonale



mm	L mm	
5	60	3 007200505
6	60	3 007200506
8	60	3 007200508
10	68	3 007200510
12	68	3 007200512
14	78	3 007200514
17	78	3 007200517
19	78	3 007200519

720ME/C8

8 chiavi a bussola Macchina maschio esagonale



720ME/C8
5-6-8-10-12
14-17-19 mm

270x120x45 mm - 1710 g

720/15

raccordo Macchina con attacco quadro femmina 1/2" e maschio 3/8"



720/15 1/2 3/8 37,5 3 007200810

720/16

raccordo Macchina con attacco quadro femmina 1/2" e maschio 3/4"



720/16 1/2 3/4 44 3 007200814

720/20

prolunga Macchina con attacchi quadri maschio e femmina 1/2"



720/20 L mm 75 3 007200818

720/21

prolunga Macchina con attacchi quadri maschio e femmina 1/2"



720/21 L mm 125 3 007200822

720/25

snodo Macchina con attacchi quadri maschio e femmina 1/2"



720/25 L mm 72 2 007200830

720/C6

6 chiavi a bussola Macchina



720/C6 1 007200910

195x80x55 mm - 1100 g

720/C12

12 chiavi a bussola Macchina



720/C12 10-11-12-13-14-17 19-22-24-27-30-32 mm 1 007200912

195x80x55 mm - 2000 g

720PT

barre di torsione Macchina per dadi ruote autoveicoli



	mm	Nm	D mm	L mm	
720PT/5	17	95	25,7	214	2 007200535
720PT/7	17	110	25,7	204	2 007200537
720PT/8	17	120	25,7	200	2 007200538
720PT/15	19	90	28,2	223	2 007200545
720PT/17	19	120	28,2	203	2 007200547
720PT/25	21	100	30,7	214	2 007200555



720PT/S6 720PT/5-720PT/7 720PT/8-720PT/15 720PT/17-720PT/25 1 007200571

720/OR... - 720/SP...

anelli e spine per bussole e accessori Macchina



720/OR1	10	007200923
720/OR2	10	007200924
720/SP1	10	007200913
720/SP2	10	007200914

727PI/16

bussola portainseri Macchina per 727/ES16 e 727/ES16TX



727PI/16 2 007270016

727/ES16

inserti Macchina maschio esagonale, attacco 16 mm

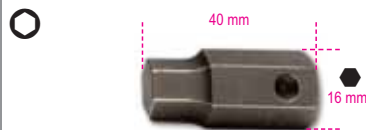

mm	
10	2 007270110
12	2 007270112
13	2 007270113
14	2 007270114
16	2 007270116
17	2 007270117
18	2 007270118
19	2 007270119
22	2 007270122

727/ES16TX

inserti Macchina maschio per viti con impronta Torx®, attacco 16 mm



T55	2 007270355
T60	2 007270360
T70	2 007270370

727PI/22

bussola portainseri Macchina per 727/ES22 e 727/ES22TX



727PI/22 2 007270022

727/ES22

inserti Macchina maschio esagonale, attacco 22 mm



mm	
19	2 007270219
22	2 007270222
24	2 007270224
27	2 007270227
30	2 007270230
32	2 007270232

727/ES22TX

inserti Macchina maschio per viti con impronta Torx®, attacco 22 mm



T80	2 007270480
T90	2 007270490
T100	2 007270500

727/C16

12 inserti Macchina maschio e 4 accessori



727/C16 1 007270900

727PI/16	
727/ES16	14-17-19 mm
727/ES16TX	T55-T60-T70
727PI/22	
727/ES22	22-24-27 mm
727/ES22TX	T80-T90-T100
96BPC	3-4 mm

335x145x60 mm - 3560 g

727PI/32

bussola portainseri Macchina per 727/ES32



727PI/32 1 007270032

727/ES32

inserti Macchina maschio esagonale, attacco 32 mm

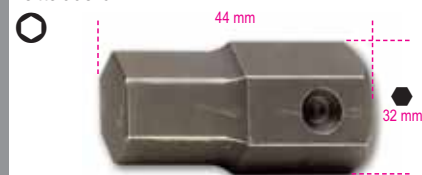

mm	
19	2 007270519
22	2 007270522
24	2 007270524
27	2 007270527
30	2 007270530
32	2 007270532
36	2 007270536

728

chiavi a bussola Macchina serie normale



UNI/ISO 2725 DIN 3129

mm	D mm	L mm	
17	30,0	51	2 007280017
18	31,0	51	2 007280018
19	32,5	51	2 007280019
21	35,0	51	2 007280021
22	36,0	51	2 007280022
23	37,5	51	2 007280023
24	38,5	51	2 007280024
27	42,5	53	2 007280027
28	44,0	53	2 007280028
30	46,0	53	2 007280030
32	48,5	57	2 007280032
33	50,0	57	2 007280033
34	51,0	57	2 007280034
36	53,5	57	2 007280036
38	56,0	57	1 007280038
41	60,0	58	1 007280041
46	66,0	62	1 007280046
50	71,0	68	1 007280050

728FTX

chiavi a bussola Macchina per viti con testa a profilo Torx®



	D mm	
E20	28,5	2 007280420
E22	30,0	2 007280422
E24	32,5	2 007280424



728L

chiavi a bussola Macchina
serie lunga



mm	D mm	
19	32,5	2 007280319
21	35,0	2 007280321
22	36,0	2 007280322
24	38,5	2 007280324
26	41,0	2 007280326
27	42,5	2 007280327
30	46,0	2 007280330
32	48,5	2 007280332
33	50,0	2 007280333
34	51,0	2 007280334
36	53,5	2 007280336
38	56,0	2 007280338
41	60,0	2 007280341

728LS

chiavi a bussola Macchina
serie lunga sottile

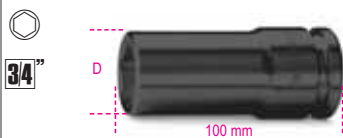

mm	D mm	
17	28,0	2 007280517
19	30,5	2 007280519
22	34,3	2 007280522
24	36,8	2 007280524
27	40,5	2 007280527
30	44,3	2 007280530
32	46,8	2 007280532
33	48,0	2 007280533
36	51,8	2 007280536

728LS/S3

serie di 3 chiavi a bussola 728LS



mm	
22-24-27	1 007280550

728/15

raccordo Macchina con attacco quadro
femmina 3/4" e maschio 1/2"



mm	L mm	
728/15	3/4 1/2	54 2 007280810

728/16

raccordo Macchina con attacco quadro
femmina 3/4" e maschio 1"



mm	L mm	
728/16	3/4 1	62 2 007280813

728/21

prolunga Macchina con attacchi quadri
maschio e femmina 3/4"



mm	L mm	
728/21	175	2 007280815

728/22

prolunga Macchina con attacchi quadri
maschio e femmina 3/4"



mm	L mm	
728/22	250	2 007280825

728/25

snodo Macchina con attacchi quadri
maschio e femmina 3/4"



mm	L mm	
728/25	107,5	1 007280830

728/C10

10 chiavi a bussola Macchina



mm	
728/C10	17-19-22-24-27-30 32-36-41-46 mm 1 007280910

275x120x65 mm - 5700 g

728/OR - 728/SP

anelli e spine per bussole e accessori
Macchina



mm	
728/OR	10 007280926
728/SP	10 007280916

729

chiavi a bussola Macchina
serie normale



UNI/ISO 2725 DIN 3129

mm	D mm	L mm	
24	41,5	58	1 007290024
27	45,0	60	1 007290027
30	49,0	62	1 007290030
32	51,5	63	1 007290032
33	52,5	63	1 007290033
34	54,0	63	1 007290034
36	56,5	66	1 007290036
38	59,0	66	1 007290038
41	62,5	68	1 007290041
46	69,0	72	1 007290046
50	74,0	76	1 007290050
55	80,0	84	1 007290055
60	86,5	88	1 007290060
65	92,5	92	1 007290065
70	99,0	96	1 007290070
75	105,0	102	1 007290075
80	111,5	102	1 007290080

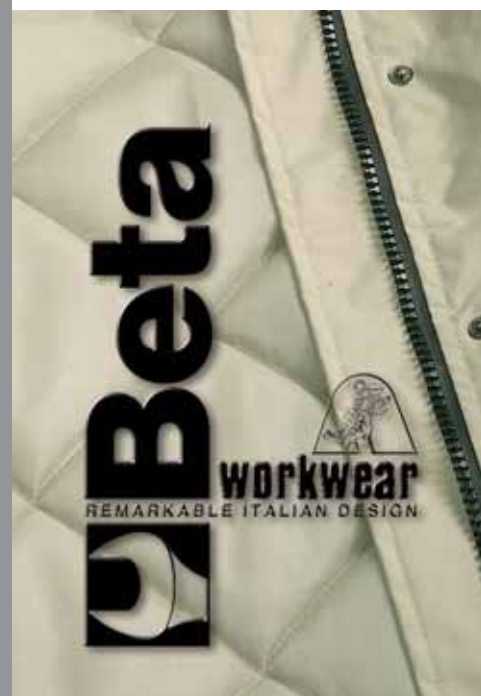

729L

chiavi a bussola Macchina serie lunga



mm	D mm	L mm		
24	41,5	108	1	007290324
27	45,0	108	1	007290327
30	49,0	108	1	007290330
32	51,5	108	1	007290332
33	52,2	108	1	007290333
34	54,0	108	1	007290334
36	56,5	108	1	007290336
41	62,5	108	1	007290341
46	69,0	108	1	007290346
50	74,0	108	1	007290350
55	80,0	108	1	007290355
60	86,5	108	1	007290360
65	92,5	108	1	007290365
70	99,0	108	1	007290370
75	105,0	108	1	007290375
80	111,5	108	1	007290380

729LS

chiavi a bussola Macchina serie lunga sottile



mm	D mm	L mm		
22	36,0	108	1	007290522
24	38,5	108	1	007290524
27	42,3	108	1	007290527
30	46,0	108	1	007290530
32	48,5	108	1	007290532
33	49,8	108	1	007290533
36	53,5	108	1	007290536

729/15

raccordo Macchina con attacco quadro femmina 1" e maschio 3/4"



		L mm		
729/15	1	3/4	66,5	1 007290810

729/16

raccordo Macchina con attacco quadro femmina 1" e maschio 1.1/2"



		L mm		
729/16	1	1.1/2	88	1 007290813

729/21

prolunga Macchina con attacchi quadri maschio e femmina 1"



	L mm		
729/21	175	1	007290815

729/22

prolunga Macchina con attacchi quadri maschio e femmina 1"



	L mm		
729/22	330	1	007290825

729/25

snodo Macchina con attacchi quadri maschio e femmina 1"



	L mm		
729/25	130	1	007290830

729/OR... - 729/SP...

anelli e spine per bussole e accessori Macchina



729/OR1	5	007290927
729/OR2	5	007290928
729/SP1	5	007290917
729/SP2	5	007290918

730

chiavi a bussola Macchina serie normale

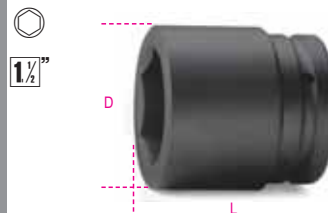

UNI/ISO 2725 DIN 3129

mm	D mm	L mm		
50	81	87	1	007300050
55	88	90	1	007300055
60	94	95	1	007300060
65	100	100	1	007300065
70	106	105	1	007300070
75	113	110	1	007300075
80	119	115	1	007300080
85	125	120	1	007300085
90	132	125	1	007300090
95	138	125	1	007300095
100	144	130	1	007300100
105	150	135	1	007300105
110	157	140	1	007300110
115	163	140	1	007300115
120	169	145	1	007300120
125	175	145	1	007300125
130	182	150	1	007300130

730/15

raccordo Macchina riduttore



		L mm		
730/15	1.1/2	1	105	1 007300810

733/15

raccordo Macchina riduttore



		L mm		
733/15	2.1/2	1.1/2	156	1 007330810

850BM

portainserti magnetico con impugnatura



L1 mm	L mm		
125	240	2	008500010

Beta



850BM/C

portainseri magnetico
con impugnatura
modello corto



L1 mm	L mm		
45	160	2	008500020

851SR

portainseri magnetico a sgancio rapido
con impugnatura



L1 mm	L mm		
110	230	2	008510001

855

portainseri con impugnatura
a cricchetto reversibile



L1 mm	L mm		
62	187	1	008550001

855T

portainseri con impugnatura a T,
con sgancio rapido universale
e cricchetto reversibile
sul lato lungo



L1 mm	L mm		
135	185	1	008550050

861LP

inserti per avvitatori
per viti a testa con intaglio

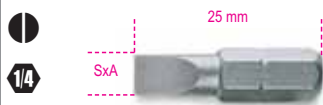

ISO 2351-1
ISO 1173 C 6,3

SxA mm		
0,5x3	10	008610005
0,6x4,5	10	008610010
0,8x5,5	10	008610015
1x5,5	10	008610020
1,2x6,5	10	008610025
1,2x8	10	008610028
1,6x8	10	008610030

861PH

inserti per avvitatori
per viti con impronta a croce Phillips®



ISO 2351-2
ISO 1173 C 6,3

PH	L mm		
0	25	10	008610200
1	25	10	008610205
2	25	10	008610210
2L	50	10	008610213
3	25	10	008610215
4	32	10	008610220

861PH/C

inserti per avvitatori
per viti con impronta a croce Phillips®



ISO 2351-2
ISO 1173 C 6,3

PH	L mm		
0	25	200	008610250
1	25	200	008610255
2	25	200	008610260
2L	50	100	008610263
3	25	200	008610265
4	32	100	008610270

861PZ

inserti per avvitatori
per viti con impronta a croce
Pozidriv® - Supadriv®



ISO 2351-2
ISO 1173 C 6,3

PZ	L mm		
1	25	10	008610300
2	25	10	008610305
2L	50	10	008610308
3	25	10	008610310
4	32	10	008610315

861PZ/C

inserti per avvitatori
per viti con impronta a croce
Pozidriv® - Supadriv®



ISO 2351-2
ISO 1173 C 6,3

PZ	L mm		
1	25	200	008610350
2	25	200	008610355
2L	50	100	008610358
3	25	200	008610360
4	32	100	008610365

861PE

inserti maschio esagonale
per avvitatori



ISO 2351-3
ISO 1173 C 6,3

mm		
2	10	008610100
2,5	10	008610105
3	10	008610110
4	10	008610115
5	10	008610120
6	10	008610125
8	10	008610130
10	10	008610135

861TX

inserti per avvitatori
per viti con impronta Torx®



ISO 1173 C 6,3

T6	10	008610400
T7	10	008610405
T8	10	008610410
T9	10	008610415
T10	10	008610420
T15	10	008610425
T20	10	008610430
T25	10	008610435
T27	10	008610440
T30	10	008610445
T40	10	008610450

861TX/C

inserti per avvitatori
per viti con impronta Torx®

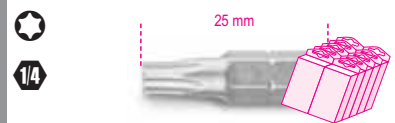

ISO 1173 C 6,3

T10	200	008610470
T15	200	008610475
T20	200	008610480
T25	200	008610485
T27	200	008610490
T30	200	008610495
T40	200	008610499

Beta
Collection

861RTX

inserti per avvitatori per viti con impronta Tamper Resistant Torx®



ISO 1173 C 6,3

T9	10 008610500
T10	10 008610505
T15	10 008610510
T20	10 008610515
T25	10 008610520
T27	10 008610525
T30	10 008610530
T40	10 008610535

861TRW

inserti per avvitatori per viti con impronta Tri-Wing®



ISO 1173 C 6,3

GR	
1	10 008610601
2	10 008610602
3	10 008610603
4	10 008610604
5	10 008610605
6	10 008610606

861TQS

inserti per avvitatori per viti con impronta Torq-Set®



ISO 1173 C 6,3

GR	
0	10 008610620
1	10 008610621
2	10 008610622
3	10 008610623
4	10 008610624
5	10 008610625
6	10 008610626
8	10 008610628
10	10 008610630

861SP

inserti per avvitatori per viti con impronta Spanner

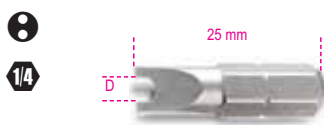

ISO 1173 C 6,3

SP	D mm	
4	1,5	10 008610650
6	2,4	10 008610653
8	2,8	10 008610656
10	3,3	10 008610658
12	3,9	10 008610660

861PHZ/S9

8 inserti con portainseri magnetico in astuccio tascabile



861PHZ/S9

1 008610340

	861PH	PH1 PH2 PH3	n. 1 2 1
	861PZ	PZ1 PZ2 PZ3	1 2 1
	882M1	○ 1/4 ● 1/4	

861PHZ/S31

30 inserti con portainseri magnetico in astuccio tascabile



861PHZ/S31

1 008610341

	861PH	PH1 PH2 PH3	n. 3 9 3
	861PZ	PZ1 PZ2 PZ3	3 9 3
	882M1	○ 1/4 ● 1/4	

861PE/S9

8 inserti maschio esagonale con portainseri magnetico in astuccio tascabile



861PE/S9

1 008610139

	861PE	2 - 2,5 - 3 - 4 - 5 - 6 - 8 - 10 mm	
	882M1	○ 1/4 ● 1/4	

861TX/S9

8 inserti con portainseri magnetico in astuccio tascabile



861TX/S9

1 008610391

	861TX	T8 - T10 - T15 - T20 - T25 T27 - T30 - T40	
	882M1	○ 1/4 ● 1/4	

861TX/S31

30 inserti con portainseri magnetico in astuccio tascabile



861TX/S31

1 008610393

	861TX	T6 - T7 - T8 T9 - T10 - T15 - T20 T25 - T27 - T30 - T40	n. 2 3
	882M1	○ 1/4 ● 1/4	

861PHT/S31

30 inserti con portainseri magnetico in astuccio tascabile



861PHT/S31

1 008610392

	861PH	PH1 PH2	n. 3 6
	861TX	T10 - T15 - T20 - T25 T27 - T30 - T40	3
	882M1	○ 1/4 ● 1/4	

861RTX/S9

8 inserti con portainseri magnetico in astuccio tascabile

1/4



861RTX/S9

1 008610536

- 861RTX T9 - T10 - T15 - T20
T25 - T27 - T30 - T40
- 882M1 ○ 1/4 ● 1/4

861MIX/S9

8 inserti con portainseri magnetico in astuccio tascabile

1/4



861MIX/S9

1 008610980

- 861LP 0,8x5,5 - 1,2x6,5 mm
- 861PH 1 - 2 - 3
- 861PZ 1 - 2 - 3
- 882M1 ○ 1/4 ● 1/4

861MIX/S31

30 inserti con portainseri magnetico in astuccio tascabile

1/4



861MIX/S31

1 008610984

- 861LP 0,5x3 - 0,6x4,5 - 0,8x5,5
1,0x5,5 - 1,2x6,5 mm
- 861PE 2 - 2,5 - 3 - 4 - 5 - 6 - 8 - 10 mm
- 861PH 0 - 1 - 2 - 3 - 4
- 861PZ 1 - 2 - 3 - 4
- 861RTX T9 - T10 - T15 - T20
T25 - T27 - T30 - T40
- 882M1 ○ 1/4 ● 1/4

861/C26N

26 inserti per avvitatori e 2 accessori

1/4



861/C26N

1 008610960

- 861LP 0,5x3 - 0,8x5,5
1,0x5,5 - 1,2x6,5 mm
- 861PE 2 - 3 - 4 - 5 - 6 - 8 mm
- 861PH 0 - 1 - 2 - 3
- 861PZ 1 - 2 - 3
- 861TX T8 - T9 - T10 - T15 - T20
T25 - T27 - T30 - T40
- 194 ○ 1/4" ○ 5/16"
- 850BM ○ 1/4"

270x120x45 mm - 950 g

861/C61P

61 inserti per avvitatori e 1 portainseri magnetico a sgancio rapido

1/4



861/C61P

1 008610978

- 861LP 0,5x3 - 0,6x4,5 - 0,8x5,5 - 1,0x5,5
1,2x6,5 - 1,2x8 - 1,6x8 mm
- 861PE 2 - 2,5 - 3 - 4 - 5 - 6 - 8 - 10 mm
- 861PH 0 - 1 - 2 - 3
- 861PZ 1 - 2 - 3
- 861TX T6 - T7 - T8 - T9 - T10 - T15
T20 - T25 - T27 - T30 - T40
- 861RTX T9 - T10 - T15 - T20 - T25
T27 - T30 - T40
- 861TRW 1 - 2 - 3 - 4 - 5 - 6
- 861TQS 0 - 1 - 2 - 3 - 4 - 5 - 6 - 8 - 10
- 861SP 4 - 6 - 8 - 10 - 12
- 851SR ○ 1/4"

270x120x45 mm - 975 g

862LP

inserti per avvitatori per viti a testa con intaglio

1/4



ISO 2351-1
ISO 1173 E 6,3

SxA mm		
0,5x3	5	008620005
0,6x4,5	5	008620010
0,8x5,5	5	008620015
1x5,5	5	008620020
1,2x6,5	5	008620025
1,2x8	5	008620030
1,6x8	5	008620035

862PH

inserti per avvitatori per viti con impronta a croce Phillips®

1/4



ISO 2351-2
ISO 1173 E 6,3

PH		
1	5	008620200
2	5	008620205
3	5	008620210

862PH/L

inserti per avvitatori per viti con impronta a croce Phillips®

1/4



ISO 2351-2
ISO 1173 E 6,3

PH		
1	5	008620230
2	5	008620232
3	5	008620234

862PZ

inserti per avvitatori per viti con impronta a croce Pozidriv® - Supadriv®

1/4



ISO 2351-2
ISO 1173 E 6,3

PZ		
1	5	008620300
2	5	008620305
3	5	008620310

Beta

ISO 9001

862PE

inserti maschio esagonale
per avvitatori



ISO 2351-3
ISO 1173 E 6,3

mm	
3	5 008620103
4	5 008620104
5	5 008620105
6	5 008620106
8	5 008620108

862TX

inserti per avvitatori per viti
con impronta Torx®



ISO 1173 E 6,3

T9	5 008620509
T10	5 008620510
T15	5 008620515
T20	5 008620520
T25	5 008620525
T27	5 008620527
T30	5 008620530
T40	5 008620540

862TX/L

inserti per avvitatori per viti
con impronta Torx®



ISO 1173 E 6,3

T9	5 008620559
T10	5 008620560
T15	5 008620565
T20	5 008620570
T25	5 008620575
T27	5 008620577
T30	5 008620580
T40	5 008620590

862F

inserti per avvitatori
chiavi a bussola esagonale magnetici



ISO 1173 E 6,3

mm	
5,5	5 008620405
6	5 008620406
7	5 008620407
8	5 008620408
10	5 008620410
12	5 008620412
13	5 008620413

866LP

inserti per avvitatori
per viti a testa con intaglio



ISO 2351-1
ISO 1173 C 8

SxA mm	
1x5,5	10 008660005
1,2x6,5	10 008660010
1,6x8	10 008660015
1,6x10	10 008660020
2x12	10 008660025

866PH

inserti per avvitatori
per viti con impronta a croce Phillips®



ISO 2351-2
ISO 1173 C 8

PH	L mm	
1	32	10 008660200
2	32	10 008660205
3	32	10 008660210
4	38	10 008660215

866PZ

inserti per avvitatori
per viti con impronta a croce
Pozidriv® - Supadriv®



ISO 2351-2
ISO 1173 C 8

PZ	L mm	
1	32	10 008660300
2	32	10 008660305
3	32	10 008660310
4	38	10 008660315

866PE

inserti maschio esagonale
per avvitatori



ISO 2351-3
ISO 1173 C 8

mm	
3	10 008660100
4	10 008660105
5	10 008660110
6	10 008660115
8	10 008660120
10	10 008660125

866TX

inserti per avvitatori
per viti con impronta Torx®



ISO 1173 C 8

T20	10 008660400
T25	10 008660405
T27	10 008660410
T30	10 008660415
T40	10 008660420
T45	10 008660425
T50	10 008660430
T55	10 008660435

867PE

inserti maschio esagonale

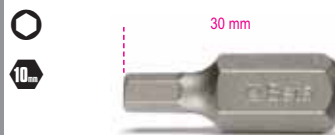

mm	
4	5 008670104
5	5 008670105
6	5 008670106
7	5 008670107
8	5 008670108
10	5 008670110
12	5 008670112

867PE/L

inserti maschio esagonale



mm	
4	5 008670154
5	5 008670155
6	5 008670156
7	5 008670157
8	5 008670158
10	5 008670160
12	5 008670162

867XZN

inserti a profilo XZN®



M5	5 008670205
M6	5 008670206
M8	5 008670208
M10	5 008670210
M12	5 008670212

867XZN/L

inserti a profilo XZN®



M5	5	008670255
M6	5	008670256
M8	5	008670258
M10	5	008670260
M12	5	008670262

867TX

inserti per viti con impronta Torx®



T20	5	008670400
T25	5	008670405
T30	5	008670410
T40	5	008670415
T45	5	008670420
T50	5	008670425
T55	5	008670430

867TX/L

inserti per viti con impronta Torx®



T20	5	008670450
T25	5	008670455
T30	5	008670460
T40	5	008670465
T45	5	008670470
T50	5	008670475
T55	5	008670480

867RTX

inserti per viti con impronta
Tamper Resistant Torx®



T20	5	008670500
T25	5	008670505
T30	5	008670510
T40	5	008670515
T45	5	008670520
T50	5	008670525
T55	5	008670530

867RTX/L

inserti per viti con impronta
Tamper Resistant Torx®



T20	5	008670550
T25	5	008670555
T30	5	008670560
T40	5	008670565
T45	5	008670570
T50	5	008670575
T55	5	008670580

867/...

bussole portainseri per 867



867/1	10 mm	3/8"	5	008670600
867/2	10 mm	1/2"	5	008670601

867/C52

52 inserti con attacco esagonale 10 mm
e 2 accessori



867/C52	1	008670901
---------	---	-----------

	867PE	4-5-6-7-8-10-12 mm
	867PE/L	4-5-6-7-8-10-12 mm
	867XZN	M5-M6-M8-M10-M12
	867XZN/L	M5-M6-M8-M10-M12
	867TX	T20-T25-T30-T40-T45-T50-T55
	867TX/L	T20-T25-T30-T40-T45-T50-T55
	867RTX	T20-T25-T30-T40-T45-T50-T55
	867RTX/L	T20-T25-T30-T40-T45-T50-T55
	867/1	10 mm - 3/8"
	867/2	10 mm - 1/2"

880

portainseri con anello di ritengo
per avvitatori



ISO 1173 A 5,5

880	1/4	5,5	L mm	D mm	5	008800001
			57	11		

880M

portainseri con anello di ritengo
per avvitatori



ISO 1173 A 5,5

880M	1/4	5,5	L mm	D mm	5	008800005
			72	10,5		

882

portainseri con anello di ritengo
per avvitatori



ISO 1173 C 6,3

882	1/4	1/4	L mm	D mm	5	008820001
			57	11		

882M

portainseri magnetico
per avvitatori

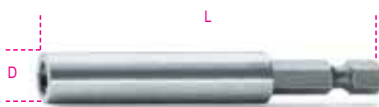

ISO 1173 C 6,3

882M	1/4	1/4	L mm	D mm	5	008820005
			75	11		

882M1

portainseri magnetico
per avvitatori



ISO 1173 C 6,3

882M1	1/4	1/4	L mm	D mm	5	008820006
			50	11		

882SR

portainseri a sgancio rapido per avvitatori



ISO 1173 C 6,3

L mm	○	●		
50	1/4	1/4	5	008820105
75	1/4	1/4	5	008820107

884

portainseri con anello di ritegno per avvitatori



○	●	L mm	D mm	
884	1/4	5/16	65	11

892

raccordi per avvitatori



	■	●	L mm	
* 892/1	1/4	5,5	50	5 008920001
* 892/2	3/8	5,5	50	5 008920002
° 892/3	1/4	1/4	50	5 008920003
° 892/4	3/8	1/4	50	5 008920004
892/5	1/4	5/16	75	5 008920005
892/6	3/8	5/16	75	5 008920006

* ISO 1173 A 5,5
° ISO 1173 C 6,3

895

bussole portainseri per 861, 862, 866



DIN 7427

○	□	L mm	D mm	
895/1	1/4	1/4	22	12
895/3	1/4	3/8	30	17,3
895/4	5/16	3/8	38	18
895/5	1/4	1/2	38	22
895/6	5/16	1/2	38	22

897

portainseri flessibile con impugnatura



L mm	L1 mm	
280	154	2 008970010

897L

portainseri flessibile con impugnatura modello lungo



L mm	L1 mm	
500	380	2 008970015

900

chiavi a bussola a mano bocca esagonale



UNI/ISO 2725 DIN 3124

mm	D mm	L mm	
4	6,7	25	10 009000040
4,5	7,4	25	10 009000045
5	8,0	25	10 009000050
5,5	8,6	25	10 009000055
6	9,3	25	10 009000060
7	10,4	25	10 009000070
8	11,8	25	10 009000080
9	12,7	25	10 009000090
10	14,2	25	10 009000100
11	15,8	25	10 009000110
12	17,2	25	10 009000120
13	18,0	25	10 009000130
14	20,0	25	10 009000140



900/SB13	
4-4,5-5-5,5-6-7-8-9	1 009000150
10-11-12-13-14 mm	

900MB

chiavi a bussola a mano bocca poligonale



UNI/ISO 2725 DIN 3124

mm	D mm	L mm	
4	7	22	5 009000160
5	7,7	22	5 009000161
5,5	8,3	22	5 009000162
6	9,0	22	5 009000163
7	10,2	22	5 009000164
8	11,3	22	5 009000165
9	13,0	22	5 009000166
10	14,3	22	5 009000167
11	16,0	22	5 009000168
12	17,4	22	5 009000169
13	18,0	22	5 009000170
14	19,3	24	5 009000171



900MB/SB12	
4-5-5,5-6-7-8-9-10	1 009000179
11-12-13-14 mm	

900L

chiavi a bussola a mano lunghe bocca esagonale

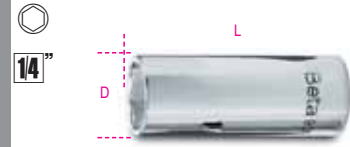

UNI/ISO 2725 DIN 3124

mm	D mm	L mm	
4	6,5	50	5 009000181
4,5	7,0	50	5 009000182
5	7,5	50	5 009000183
5,5	8,5	50	5 009000184
6	9,5	50	5 009000185
7	10,5	50	5 009000186
8	12,0	50	5 009000187
9	13,0	50	5 009000188
10	14,0	50	5 009000189
11	16,0	50	5 009000190
12	17,5	50	5 009000191
13	17,5	50	5 009000192
14	20,0	50	5 009000193

900MB/L

chiavi a bussola a mano lunghe bocca poligonale

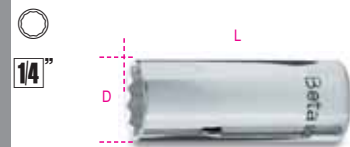

UNI/ISO 2725 DIN 3124

mm	D mm	L mm	
5	8,0	50	5 009000211
6	9,3	50	5 009000212
7	10,9	50	5 009000213
8	11,6	50	5 009000214
9	13,0	50	5 009000215
10	14,3	50	5 009000216
11	16,0	50	5 009000217
12	17,4	50	5 009000218
13	18,0	50	5 009000219
14	19,0	50	5 009000220

900AS

chiavi a bussola a mano bocca esagonale



mm	D mm	L mm	
5/32	6,5	22	5 009000349
3/16	7,4	22	5 009000340
7/32	8,6	22	5 009000345

	D mm	L mm		
1/4	9,6	22	5	009000350
9/32	10,4	22	5	009000355
5/16	11,8	22	5	009000360
11/32	12,7	22	5	009000365
3/8	14,2	22	5	009000370
7/16	15,8	22	5	009000375
1/2	17,2	22	5	009000380
9/16	20,0	24	5	009000385

900AS/MB

chiavi a bussola a mano
bocca poligonale



SAE AS 954E

	D mm	L mm		
3/16	8,0	22	5	009000390
7/32	8,6	22	5	009000391
1/4	9,6	22	5	009000392
9/32	10,0	22	5	009000393
5/16	11,9	22	5	009000394
11/32	12,0	22	5	009000395
3/8	13,9	22	5	009000396
7/16	15,2	22	5	009000397
1/2	17,2	22	5	009000398
9/16	19,0	24	5	009000399

900AS/L

chiavi a bussola a mano lunghe
bocca esagonale



	D mm	L mm		
3/16	7,0	50	5	009000301
7/32	8,5	50	5	009000303
1/4	9,8	50	5	009000305
9/32	10,5	50	5	009000307
5/16	12,0	50	5	009000309
11/32	13,0	50	5	009000311
3/8	14,0	50	5	009000313
7/16	16,0	50	5	009000315
1/2	17,5	50	5	009000317
9/16	20,0	50	5	009000319

900AS/MBL

chiavi a bussola a mano lunghe
bocca poligonale

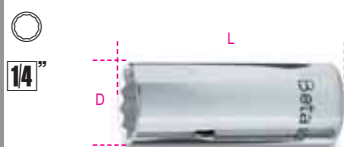

	D mm	L mm		
5/32	6,8	50	5	009000325
3/16	8,0	50	5	009000326
7/32	8,5	50	5	009000327
1/4	9,8	50	5	009000328

	D mm	L mm		
9/32	10,9	50	5	009000329
5/16	11,6	50	5	009000330
11/32	13,0	50	5	009000331
3/8	14,3	50	5	009000332
7/16	16,0	50	5	009000333
1/2	18,0	50	5	009000334
9/16	19,0	50	5	009000335

900FTX

chiavi a bussola a mano per viti
con teste a profilo Torx®



	D mm	D1 mm		
E4	5,4	11,2	5	009000404
E5	6,7	11,2	5	009000405
E6	7,7	11,2	5	009000406
E7	8,3	11,2	5	009000407
E8	9,6	11,2	5	009000408
E10	11,3	12,0	5	009000410

900LP

chiavi a bussola a giravite
per viti con intaglio



SxA mm	D mm		
0,8x4	12	10	009000605
1x5,5	12	10	009000610
1,2x6,5	12	10	009000615
1,2x8	13	10	009000620
1,6x10	14	10	009000625

900PH

chiavi a bussola a giravite
per viti con impronta a croce Phillips®



PH	D mm		
1	12	10	009000701
2	12	10	009000702
3	12	10	009000703
4	13	10	009000704

900ME

chiavi a bussola a giravite
maschio esagonale



mm	D mm		
2,5	12	10	009000502
3	12	10	009000503
4	12	10	009000504
5	12	10	009000505
6	12	10	009000506
7	13	10	009000507
8	13	10	009000508

900PT

chiavi a bussola a giravite per viti con
impronta pentalobata

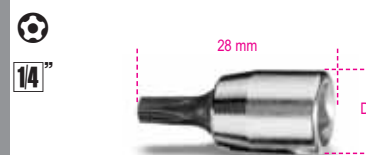

PT	D mm		
PT10	12	5	009000750
PT15	12	5	009000755
PT20	12	5	009000760
PT25	12	5	009000765
PT27	12	5	009000767
PT30	12	5	009000770

900TX

chiavi a bussola a giravite maschio
per viti con impronta Torx®



T	D mm		
T9	12	5	009000720
T10	12	5	009000721
T15	12	5	009000722
T20	12	5	009000723
T25	12	5	009000724
T27	12	5	009000725
T30	12	5	009000726
T40	12	5	009000727

900/16

raccordo con attacco quadro
femmina 1/4" e maschio 3/8"



UNI/ISO 3316 DIN 3123

	L mm		
1/4	3/8	22	5 009000814

900/...

prolunghe con attacchi quadri maschio e femmina 1/4"

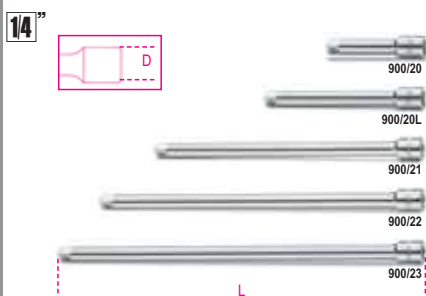

UNI/ISO 3316 DIN 3123

	L mm	D mm	
900/20	50	11,5	5 009000818
900/20L	100	11,5	5 009000819
900/21	150	11,5	5 009000822
900/22	250	11,5	5 009000823
900/23	350	11,5	5 009000824

900AN

prolunghe con attacchi quadri maschio e femmina 1/4" angolari

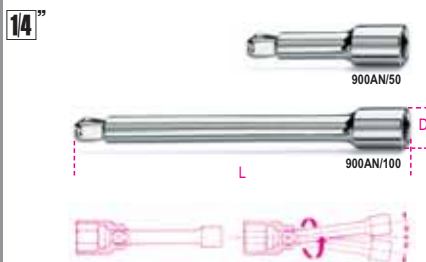

	L mm	D mm	
900AN/50	50	11,5	3 009000825
900AN/100	100	11,5	3 009000826

900FL

prolunga flessibile con attacchi quadri maschio e femmina 1/4"



L mm	D mm	
150	12	3 009000828

900/25

snodo con attacchi quadri maschio e femmina 1/4"



UNI/ISO 3316 DIN 3123

L mm	D mm	
41	12,5	5 009000830

900/30

quadro maschio 1/4" con impugnatura



UNI/ISO 3315 DIN 3122

L mm	
176	5 009000835

900/32

quadro maschio 1/4" flessibile con impugnatura



L mm	L1 mm	
280	154	2 009000839

900/35A

quadro maschio 1/4" snodato con impugnatura



UNI/ISO 3315 DIN 3122

L mm	
148	5 009000840

900M/35

quadro maschio 1/4" snodato con impugnatura in metallo



L mm	
130	3 009000845

900/40

quadro maschio 1/4" snodato a T



L mm	
390	5 009000843

900/42

quadro maschio 1/4" con spina scorrevole



UNI/ISO 3315 DIN 3122

L mm	
115	5 009000854

900/55

cricchetto reversibile con attacco quadro maschio 1/4" meccanismo a 48 denti



UNI/ISO 3315 DIN 3122

L mm	D mm	A mm	
125	25	18	5 009000870

900M/55

cricchetto reversibile con attacco quadro maschio 1/4" con impugnatura in metallo



L mm	D mm	A mm	
110	22	18	3 009000905

900M/56

cricchetto reversibile snodato con attacco quadro maschio 1/4" con impugnatura in metallo



L mm	D mm	A mm	
165	25	18	3 009000907

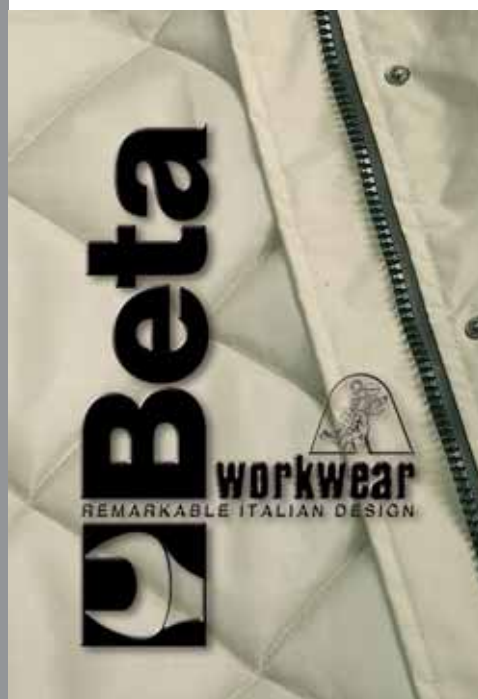

900/C11

11 chiavi a bussola esagonali,
20 inserti per avvitatori e 8 accessori

14"
1/4"



900/C11

1 009000970

	861LP	0,5x3 - 0,8x5,5 1x5,5 - 1,2x6,5 mm
	861PE	3 - 4 - 5 - 6 - 8 mm
	861PH	0 - 1 - 2 - 3
	861TX	T8 - T10 - T15 - T20 T25 - T30 - T40
	895/1	
	900	5 - 5,5 - 6 - 7 - 8 - 9 - 10 11 - 12 - 13 - 14 mm
	900/16	□ 1/4 - ■ 3/8
	900/20	50 mm
	900/21	150 mm
	900/25	
	900/30	
	900/42	
	900/55	

≡ 270x120x45 mm - i 1200 g

900/C13-5

13 chiavi a bussola esagonali
e 5 accessori

14"



900/C13-5

1 009000950

	900	4 - 4,5 - 5 - 5,5 - 6 - 7 - 8 - 9 10 - 11 - 12 - 13 - 14 mm
	900/21	150 mm
	900/25	
	900/30	
	900/42	
	900/55	

≡ 270x120x45 mm - i 1000 g

900/C13-8

13 chiavi a bussola esagonali
e 8 accessori

14"



900/C13-8

1 009000951

	900	4 - 4,5 - 5 - 5,5 - 6 - 7 - 8 - 9 10 - 11 - 12 - 13 - 14 mm
	900/16	□ 1/4 - ■ 3/8
	900/20	50 mm
	900/21	150 mm
	900/25	
	900/30	
	900/35A	
	900/42	
	900/55	

≡ 270x120x45 mm - i 1100 g

900MB/C19

11 chiavi a bussola poligonali
e 8 accessori

14"



900MB/C19

1 009000972

	900MB	5 - 5,5 - 6 - 7 - 8 - 9 - 10 - 11 12 - 13 - 14 mm
	900/16	□ 1/4 - ■ 3/8
	900/20	50 mm
	900/21	150 mm
	900/25	
	900/30	
	900/35A	
	900/42	
	900/55	

≡ 270x120x45 mm - i 1080 g

900/C24

13 chiavi a bussola esagonali
11 a giravite e 6 accessori

14"



900/C24

1 009000955

	900	4 - 4,5 - 5 - 5,5 - 6 - 7 - 8 - 9 10 - 11 - 12 - 13 - 14 mm
	900LP	0,8x4 - 1,2x6,5 - 1,2x8 mm
	900PH	PH1 - PH2 - PH3
	900ME	3 - 4 - 5 - 6 - 8 mm
	900/20	50 mm
	900/21	150 mm
	900/25	
	900/30	
	900/42	
	900/55	

≡ 270x120x45 mm - i 1150 g

900MB/C28

11 chiavi a bussola poligonali
11 a giravite e 6 accessori

14"



900MB/C28

1 009000973

	900MB	5 - 5,5 - 6 - 7 - 8 - 9 - 10 - 11 12 - 13 - 14 mm
	900LP	0,8x4 - 1,2x6,5 - 1,2x8 mm
	900PH	PH1 - PH2 - PH3
	900ME	3 - 4 - 5 - 6 - 8 mm
	900/20	50 mm
	900/21	150 mm
	900/25	
	900/30	
	900/42	
	900/55	

≡ 270x120x45 mm - i 1130 g

Beta

ISO 9001

900AS/C10 - /MB-C17

10 chiavi a bussola
e 7 accessori

1/4"



900AS/C10 1 009000959

	○ 900AS	3/16 - 7/32 - 1/4 - 9/32 - 5/16 11/32 - 3/8 - 7/16 - 1/2 - 9/16
	900/20	50 mm
	900/21	150 mm
	900/25	
	900/30	
	900/35A	
	900/42	
	900/55	
≡ 270x120x45 mm - 📦 1080 g		



900AS/MB-C17 1 009000974

	○ 900AS/MB	3/16 - 7/32 - 1/4 - 9/32 - 5/16 11/32 - 3/8 - 7/16 - 1/2 - 9/16
	900/20	50 mm
	900/21	150 mm
	900/25	
	900/30	
	900/35A	
	900/42	
	900/55	
≡ 270x120x45 mm - 📦 1080 g		

900AS/C17-MBM

10 chiavi a bussola poligonali
e 7 accessori
per manutenzioni aeronautiche

1/4"



900AS/C17-MBM 1 009000976

	○ 900AS/MB	3/16 - 7/32 - 1/4 - 9/32 - 5/16 11/32 - 3/8 - 7/16 - 1/2 - 9/16
	900/20	50 mm
	900/21	150 mm
	900/25	
	900/30	
	900M/35	
	900/42	
	900M/55	
≡ 270x120x45 mm - 📦 1200 g		

900/C30

7 chiavi a bussola esagonale,
21 inserti per avvitatori e 2 accessori

1/4"

3/8"



900/C30 1 009000958

	○ 855	1/4"
	● 861LP	0,8x5,5 - 1x5,5 - 1,2x6,5 mm
	⊕ 861PH	1 - 2(x2) - 3
	⬢ 861PE	2 - 2,5 - 3 - 4 - 5 mm
	⊕ 861PZ	1 - 2(x2) - 3
	⊕ 861RTX	T9 - T10 - T15 - T20 - T25
	892/3	■ 1/4 ● 1/4
	○ 900	5 - 5,5 - 6 - 7 - 8 - 10 - 13 mm
≡ 270x120x45 mm - 📦 950 g		

902R/C6

6 raccordi per chiavi a bussola



902R/C6 1 009020814

	900/16	□ 1/4 - ■ 3/8
	910/15	□ 3/8 - ■ 1/4
	910/16	□ 3/8 - ■ 1/2
	920/15	□ 1/2 - ■ 3/8
	920/16	□ 1/2 - ■ 3/4
	928/15	□ 3/4 - ■ 1/2
≡ 170x100x35 mm - 📦 600 g		

910A

chiavi a bussola a mano
bocca esagonale

3/8"

3/8"



UNI/ISO 2725 DIN 3124

mm	D mm	L mm	📦
6	9,5	28	5 009100006
7	10,7	28	5 009100007
8	12,1	28	5 009100008
9	13,2	28	5 009100009
10	14,6	29	5 009100010
11	15,8	29	5 009100011

mm	D mm	L mm	📦
12	17,2	30	5 009100012
13	18,4	31	5 009100013
14	19,7	32	5 009100014
15	20,9	32	5 009100015
16	22,2	33	5 009100016
17	23,2	33	5 009100017
18	24,7	34	5 009100018
19	25,8	35	5 009100019
20	27,2	35	5 009100020
21	28,2	36	5 009100021
22	29,7	37	5 009100022

3/8"



910A/SB17 1 009100030

6-7-8-9-10-11-12
13-14-15-16-17
18-19-20-21-22 mm

910B

chiavi a bussola a mano
bocca poligonale

3/8"

3/8"



UNI/ISO 2725 DIN 3124

mm	D mm	L mm	📦
6	9,5	28	5 009100106
7	10,7	28	5 009100107
8	12,1	28	5 009100108
9	13,2	28	5 009100109
10	14,6	29	5 009100110
11	15,8	29	5 009100111
12	17,2	30	5 009100112
13	18,4	31	5 009100113
14	19,7	32	5 009100114
15	20,9	32	5 009100115
16	22,2	33	5 009100116
17	23,2	33	5 009100117
18	24,7	34	5 009100118
19	25,8	35	5 009100119
20	27,2	35	5 009100120
21	28,2	36	5 009100121
22	29,7	37	5 009100122

3/8"



910B/SB17 1 009100130

6-7-8-9-10-11-12
13-14-15-16-17
18-19-20-21-22 mm

910AL

chiavi a bussola a mano lunghe
bocca esagonale



UNI/ISO 2725 DIN 3124

mm	D mm	L mm	
8	12,0	55	5 009100158
9	13,0	55	5 009100159
10	14,5	55	5 009100160
11	16,0	55	5 009100161
12	17,0	55	5 009100162
13	18,0	55	5 009100163
14	20,0	55	5 009100164
15	21,0	55	5 009100165
16	22,0	55	5 009100166
17	23,5	55	5 009100167
18	24,5	55	5 009100168
19	25,0	55	5 009100169
21	27,0	65	5 009100171
22	29,0	65	5 009100172



910AL/SB14

8-9-10-11-12-13-14
15-16-17-18-19-21-22 mm

910BL

chiavi a bussola a mano lunghe
bocca poligonale



UNI/ISO 2725 DIN 3124

mm	D mm	L mm	
8	12,0	55	5 009100308
9	13,0	55	5 009100309
10	14,5	55	5 009100310
11	16,0	55	5 009100311
12	17,0	55	5 009100312
13	18,0	55	5 009100313
14	20,0	55	5 009100314
15	21,0	55	5 009100315
16	22,0	55	5 009100316
17	23,5	55	5 009100317
18	24,5	55	5 009100318
19	25,0	55	5 009100319
21	27,0	65	5 009100321
22	29,0	65	5 009100322

3/8"



910BL/SB14

8-9-10-11-12-13
14-15-16-17-18
19-21-22 mm

910B/SN

chiavi a bussola a mano snodate
bocca poligonale

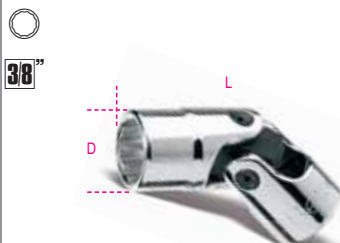

mm	D mm	L mm	
10	14,5	48,5	5 009100230
11	15,8	49,5	5 009100231
12	17,0	50,0	5 009100232
13	18,3	51,0	5 009100233
14	19,5	51,0	5 009100234
15	20,8	53,5	5 009100235
16	22,0	53,5	5 009100236
17	23,3	54,5	5 009100237
18	24,5	54,5	5 009100238
19	25,8	56,5	5 009100239

910A/AS

chiavi a bussola a mano
bocca esagonale



	D mm	L mm	
1/4	10,3	26	5 009100276
5/16	11,9	26	5 009100278
11/32	13,3	26	5 009100279
3/8	13,9	26	5 009100280
7/16	15,8	26	5 009100281
1/2	17,9	26	5 009100283
9/16	19,5	27	5 009100284
19/32	20,6	27	5 009100285
5/8	21,9	28	5 009100286
11/16	24,6	30	5 009100287
3/4	25,9	30	5 009100289
13/16	27,9	32	5 009100291
7/8	29,6	32	5 009100292



910A-AS/SB13

1/4-5/16-11/32-3/8-7/16
1/2-9/16-19/32-5/8-11/16
3/4-13/16-7/8

910AS

chiavi a bussola a mano
bocca poligonale



	D mm	L mm	
1/4	9,5	28	5 009100201
5/16	12,1	28	5 009100202
11/32	13,2	28	5 009100203
3/8	14,6	29	5 009100204
7/16	15,8	29	5 009100205
1/2	18,4	31	5 009100206
9/16	19,7	32	5 009100207
19/32	20,9	32	5 009100208
5/8	22,2	33	5 009100209
11/16	24,7	34	5 009100210
3/4	25,8	35	5 009100211
13/16	28,2	36	5 009100212
7/8	29,7	37	5 009100213



910AS/SB13

1/4-5/16-11/32-3/8-7/16
1/2-9/16-19/32-5/8-11/16
3/4-13/16-7/8

910AS/L

chiavi a bussola a mano lunghe
bocca poligonale



	D mm	L mm	
1/4	10	55	5 009100350
5/16	12	55	5 009100351
3/8	14	55	5 009100352
7/16	16	55	5 009100353
1/2	18	55	5 009100354
9/16	20	55	5 009100355
19/32	21	55	5 009100356
5/8	22	55	5 009100357
11/16	23	55	5 009100359
3/4	25	55	5 009100360
13/16	27	65	5 009100362
7/8	29	65	5 009100363



910ASL/SB12

1/4-5/16-3/8-7/16
1/2-9/16-19/32-5/8-11/16
3/4-13/16-7/8

Beta
SHOP
in Shop

910AS/SN

chiavi a bussola a mano snodate
bocca poligonale



* SAE AS 954E

	D mm	L mm		
* 3/8	14,0	48,0	5	009100260
* 7/16	15,8	51,0	5	009100261
* 1/2	18,3	51,0	5	009100262
* 9/16	19,5	51,0	5	009100263
* 5/8	22,0	53,5	5	009100264
11/16	24,5	54,5	5	009100265
3/4	25,8	56,5	5	009100266

910FTX

chiavi a bussola a mano per viti
con testa a profilo Torx®

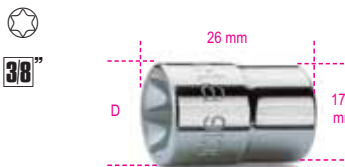

	D mm		
E4	6,2	5	009100404
E5	7,0	5	009100405
E6	8,3	5	009100406
E7	8,9	5	009100407
E8	9,9	5	009100408
E10	12,0	5	009100410
E12	14,5	5	009100412
E14	15,8	5	009100414
E16	18,0	5	009100416



910FTX/SB9	1	009100430
E4-E5-E6-E7-E8		
E10-E12-14-E16		

910FTX/L

chiavi a bussola a mano lunghe
per viti con testa a profilo Torx®

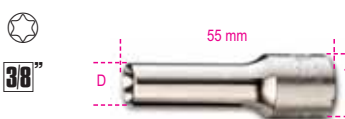

	D mm		
E4	6,2	5	009100440
E5	7,0	5	009100441
E6	8,3	5	009100442
E7	8,9	5	009100443
E8	9,9	5	009100444
E10	12,0	5	009100445



910FTX/LSB6	1	009100449
E4-E5-E6		
E7-E8-E10		

910LP

chiavi a bussola a giravite
per viti con intaglio



SxA mm		
1x5,5	5	009100452
1,2x6,5	5	009100453
1,2x8	5	009100454
1,6x9	5	009100456

910PH

chiavi a bussola a giravite
per viti con impronta a croce Phillips®

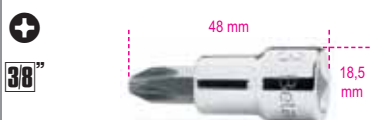

PH		
1	5	009100471
2	5	009100472
3	5	009100473
4	5	009100474

910LH/SB7

chiavi a bussola a giravite
per viti con intaglio e
con impronta a croce Phillips®



910LH/SB7	1	009100479
910LP	1x5,5 - 1,2x6,5 - 1,2x8 - 1,6x9	
910PH	PH1 - PH2 - PH3	

910PE

chiavi a bussola maschio esagonale

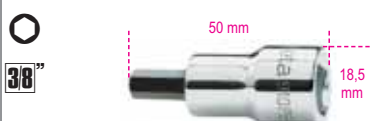

mm		
3	5	009100490
4	5	009100492
5	5	009100494
6	5	009100496
7	5	009100497
8	5	009100498
10	5	009100500



910PE/SB7	1	009100503
3-4-5-6-7-8-10 mm		

910ME

chiavi a bussola maschio esagonale



mm	D mm		
4	18	5	009100504
5	18	5	009100505
6	18	5	009100506
7	18	5	009100507
8	19	5	009100508
10	20	5	009100510
12	20	5	009100512

910PT

chiavi a bussola a giravite per viti con
impronta pentalobata



910PT/SB8	1	009100558
PT40	3	009100540
PT45	3	009100545
PT50	3	009100550



910PT/SB8	1	009100558
PT10-PT15-PT20-PT25		
PT30-PT40-PT45-PT50		

910TX

chiavi a bussola maschio
per viti con impronta Torx®



910TX/SB8	1	009100558
T15	5	009100519
T20	5	009100520
T25	5	009100521
T27	5	009100522
T30	5	009100523
T40	5	009100524

3/8"



910TX/SB6
T15-T20-T25
T27-T30-T40

1 009100530

910CF

chiavi a zampa di gallo

3/8"



Ø mm	A mm	L mm	
10	21,3	32,3	5 009100135
11	23,1	34,3	5 009100136
12	25,5	36,2	5 009100137
13	26,9	37,4	5 009100138
14	30,2	40,0	5 009100139
15	33,3	41,3	5 009100140
16	33,3	41,3	5 009100141
17	38,1	46,5	5 009100142
18	38,1	46,5	5 009100143
19	39,6	48,0	5 009100144

3/8"



910CF/SB10
10-11-12-13-14-15
16-17-18-19 mm

1 009100147

910/15

raccordo con attacco quadro
femmina 3/8" e maschio 1/4"

3/8"



UNI/ISO 3316 DIN 3123

□	■	L mm	
3/8	1/4	30	5 009100810

910/16

raccordo con attacco quadro
femmina 3/8" e maschio 1/2"

3/8"



UNI/ISO 3316 DIN 3123

□	■	L mm	
3/8	1/2	32	5 009100814

910/21 - 910/22

prolunghe con attacchi quadri
maschio e femmina 3/8"

3/8"



UNI/ISO 3316 DIN 3123

	L mm	D mm	
910/21	125	17	5 009100822
910/22	250	17	5 009100826

910AN

prolunghe con attacchi quadri
maschio e femmina 3/8"
angolari

3/8"

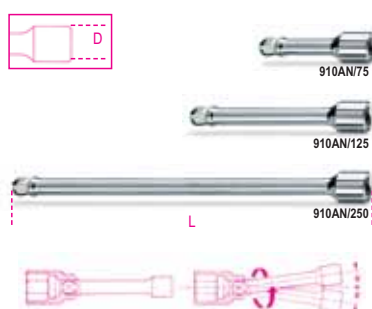

	L mm	D mm	
910AN/75	75	17	3 009100827
910AN/125	125	17	3 009100828
910AN/250	250	17	3 009100829

910/25

snodo con attacchi quadri
maschio e femmina 3/8"

3/8"



UNI/ISO 3316 DIN 3123

L mm	D mm	
54,6	19	5 009100830

910M/35

quadro maschio 3/8" snodato
con impugnatura in metallo

3/8"



UNI/ISO 3315 DIN 3122

L mm	
250	3 009100839

910M/35L

quadro maschio 3/8" snodato
con impugnatura in metallo, lungo

3/8"



L mm	
380	2 009100841



È assolutamente necessario applicare
il carico di torsione adeguatamente
e progressivamente per evitare rotture
o danni accidentali.

910/36A

quadro maschio 3/8" snodato
con impugnatura

3/8"



UNI/ISO 3315 DIN 3122

L mm	
255	3 009100845

910/40

quadro maschio 3/8"
snodato a T

3/8"



L mm	
420	3 009100850

910/42

quadro maschio 3/8"
con spina scorrevole

3/8"



UNI/ISO 3315 DIN 3122

L mm	
210	5 009100854

910/46

quadro maschio 3/8"
con manovella

3/8"



UNI/ISO 3315 DIN 3122

L mm	
315	1 009100862

910/55

cricchetto reversibile
con attacco quadro maschio 3/8"
meccanismo a 72 denti



UNI/ISO 3315 DIN 3122

L mm	D mm	A mm	
200	30	33	3 009100882

910/55Q

cricchetto reversibile
con attacco quadro maschio 3/8"
meccanismo a 48 denti



UNI/ISO 3315 DIN 3122

L mm	D mm	A mm	
200	30	33	3 009100885

910M/55

cricchetto reversibile
con attacco quadro maschio 3/8"
con impugnatura in metallo



L mm	D mm	A mm	
178	30	26	2 009100875

910M/56

cricchetto reversibile snodato
con attacco quadro maschio 3/8"
con impugnatura in metallo



L mm	D mm	A mm	
265	31	29	2 009100887

910.../C10

10 chiavi a bussola
e 2 accessori



910A/C10 1 009100909

	910A	
	6 - 7 - 8 - 10 - 11 - 12	
	13 - 14 - 17 - 19 mm	
	910/21	125 mm
	910/55	

270x120x45 mm - 1340 g

910B/C10 1 009100910

	910B	
	6 - 7 - 8 - 10 - 11 - 12	
	13 - 14 - 17 - 19 mm	
	910/21	125 mm
	910/55	

270x120x45 mm - 1320 g

910A/C16...

16 chiavi a bussola esagonali
e 5 accessori



910A/C16 1 009100936

	910A	
	6 - 7 - 8 - 9 - 10 - 11 - 12 - 13	
	14 - 15 - 16 - 17 - 18 - 19	
	21 - 22 mm	
	910/21	125 mm
	910/22	250 mm
	910/25	
	910/42	
	910/55	

335x145x60 mm - 2360 g

910A/C16Q 1 009100932

	910A	
	6 - 7 - 8 - 9 - 10 - 11 - 12 - 13	
	14 - 15 - 16 - 17 - 18 - 19	
	21 - 22 mm	
	910/21	125 mm
	910/22	250 mm
	910/25	
	910/42	
	910/55Q	

335x145x60 mm - 2360 g

910B/C16...

16 chiavi a bussola poligonali
e 5 accessori



910B/C16 1 009100937

	910B	
	6 - 7 - 8 - 9 - 10 - 11 - 12 - 13	
	14 - 15 - 16 - 17 - 18 - 19	
	21 - 22 mm	
	910/21	125 mm
	910/22	250 mm
	910/25	
	910/42	
	910/55	

335x145x60 mm - 2340 g

910B/C16Q 1 009100933

	910B	
	6 - 7 - 8 - 9 - 10 - 11 - 12 - 13	
	14 - 15 - 16 - 17 - 18 - 19	
	21 - 22 mm	
	910/21	125 mm
	910/22	250 mm
	910/25	
	910/42	
	910/55Q	

335x145x60 mm - 2340 g

Beta

910A/C17

17 chiavi a bussola esagonali
e 9 accessori

38"



910A/C17

1 009100938

	910A	6 - 7 - 8 - 9 - 10 - 11 - 12 - 13 14 - 15 - 16 - 17 - 18 - 19 - 20 21 - 22 mm
	910/15	□ 3/8 - ■ 1/4
	910/16	□ 3/8 - ■ 1/2
	910/21	125 mm
	910/22	250 mm
	910/25	
	910/36A	
	910/42	
	910/46	
	910/55	

420x280x60 mm - 4000 g

910.../C29

17 chiavi a bussola
12 a giravite e 5 accessori

38"



910A/C29

1 009100944

	910A	6 - 7 - 8 - 9 - 10 - 11 - 12 - 13 14 - 15 - 16 - 17 - 18 - 19 - 20 21 - 22 mm
	910LP	1x5,5 - 1,2x6,5 - 1,2x8 mm
	910PH	PH1 - PH2 - PH3
	910PE	3 - 4 - 5 - 6 - 8 - 10 mm
	910/21	125 mm
	910/22	250 mm
	910/25	
	910/42	
	910/55	

420x185x60 mm - 3450 g

910B/C29

1 009100945

	910B	6 - 7 - 8 - 9 - 10 - 11 - 12 - 13 14 - 15 - 16 - 17 - 18 - 19 - 20 21 - 22 mm
	910LP	1x5,5 - 1,2x6,5 - 1,2x8 mm
	910PH	PH1 - PH2 - PH3
	910PE	3 - 4 - 5 - 6 - 8 - 10 mm
	910/21	125 mm
	910/22	250 mm
	910/25	
	910/42	
	910/55	

420x185x60 mm - 3410 g

910AS/C13...

13 chiavi a bussola poligonali
e 5 accessori

38"



910AS/C13

1 009100925

	910AS	1/4 - 5/16 - 11/32 - 3/8 - 7/16 1/2 - 9/16 - 19/32 - 5/8 - 11/16 3/4 - 13/16 - 7/8
	910/21	125 mm
	910/22	250 mm
	910/42	
	910/25	
	910/55	

335x145x60 mm - 2250 g

910AS/MBM-C18

13 chiavi a bussola poligonali
e 5 accessori
per manutenzioni aeronautiche

38"



910AS/MBM-C18

1 009100926

	910AS	1/4 - 5/16 - 11/32 - 3/8 - 7/16 1/2 - 9/16 - 19/32 - 5/8 - 11/16 3/4 - 13/16 - 7/8
	910/21	125 mm
	910/22	250 mm
	910/25	
	910/42	
	910M/55	

335x145x60 mm - 2500 g

920A

chiavi a bussola a mano
bocca esagonale



12"



UNI/ISO 2725 DIN 3124

mm	D mm	L mm	
8	12,4	38	10 009200008
9	13,5	38	10 009200009
10	14,9	38	10 009200010
11	16,1	38	10 009200011
12	17,5	38	10 009200012
13	18,7	38	10 009200013
14	20,1	38	10 009200014
15	21,5	38	10 009200015
16	22,7	38	10 009200016
17	24,1	38	10 009200017
18	25,3	39	10 009200018
19	26,6	39	10 009200019
20	27,8	40	5 009200020
21	28,8	40	5 009200021
22	29,9	41	5 009200022
23	30,8	42	5 009200023
24	32,2	43	5 009200024
25	33,2	44	5 009200025
26	34,7	45	5 009200026
27	36,2	46	5 009200027
28	37,2	47	5 009200028
29	38,6	48	5 009200029
30	40,2	48	5 009200030
32	42,3	49	5 009200032

12"



920A/SB13

10-11-12-13-14-15-16
17-18-19-20-21-22 mm

1 009200040

12"



920A/SB8

23-24-25-26-27
28-30-32 mm

1 009200042

920MQ/A

chiavi a bussola esagonali



12"



1000 V

EN 60900

mm	D mm	L mm	
10	21,5	57	2 009200240
11	21,5	57	2 009200241
12	23,0	57	2 009200242

mm	D mm	L mm		
13	23,0	57	2	009200243
14	23,0	57	2	009200244
17	30,0	57	2	009200247
19	32,2	57	2	009200249
22	36,0	57	2	009200252
24	39,0	57	2	009200254

920B

chiavi a bussola a mano
bocca poligonale

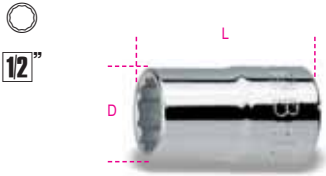

UNI/ISO 2725 DIN 3124

mm	D mm	L mm		
8	12,4	38	10	009200108
9	13,5	38	10	009200109
10	14,9	38	10	009200110
11	16,1	38	10	009200111
12	17,5	38	10	009200112
13	18,7	38	10	009200113
14	20,1	38	10	009200114
15	21,5	38	10	009200115
16	22,7	38	10	009200116
17	24,1	38	10	009200117
18	25,3	39	10	009200118
19	26,6	39	10	009200119
20	27,8	40	5	009200120
21	28,8	40	5	009200121
22	29,9	41	5	009200122
23	30,8	42	5	009200123
24	32,2	43	5	009200124
25	33,2	44	5	009200125
26	34,7	45	5	009200126
27	36,2	46	5	009200127
28	37,2	47	5	009200128
29	38,6	48	5	009200129
30	40,2	48	5	009200130
32	42,3	49	5	009200132



920B/SB13
10-11-12-13-14-15-16
17-18-19-20-21-22 mm

1 009200140



920B/SB8
23-24-25-26-27
28-30-32 mm

1 009200142

920AL

chiavi a bussola a mano lunghe
bocca esagonale



UNI/ISO 2725 DIN 3124

mm	D mm	L mm		
10	14,7	77	5	009200626
12	17,8	77	5	009200627
13	19,0	77	5	009200628
14	20,3	77	5	009200629
15	21,5	77	5	009200630
16	22,8	77	5	009200631
17	24,0	77	5	009200632
18	25,0	77	5	009200633
19	26,5	77	5	009200634
21	29,0	77	5	009200635
22	30,0	77	5	009200636
23	31,5	77	5	009200637
24	32,8	77	5	009200638
27	36,5	77	3	009200639
30	40,0	77	3	009200640
32	42,8	77	3	009200641
36	48,0	77	3	009200642



920AL/SB11
10-12-13-14-15-16
17-18-19-21-22 mm

1 009200644

920BL

chiavi a bussola a mano lunghe
bocca poligonale



UNI/ISO 2725 DIN 3124

mm	D mm	L mm		
10	14,7	77	5	009200310
12	17,8	77	5	009200312
13	19,0	77	5	009200313
14	20,3	77	5	009200314
15	21,5	77	5	009200315
16	22,8	77	5	009200316
17	24,0	77	5	009200317
18	25,0	77	5	009200318
19	26,5	77	5	009200319
21	29,0	77	5	009200321
22	30,0	77	5	009200322
23	31,5	77	5	009200323
24	32,8	77	5	009200324
27	36,5	77	3	009200327
30	40,0	77	3	009200330
32	42,8	77	3	009200332
36	48,0	77	3	009200336



920BL/SB11
10-12-13-14-15-16-17-18
19-21-22 mm

1 009200338

920A/AS

chiavi a bussola a mano
bocca esagonale

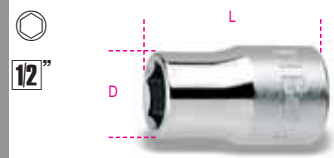

mm	D mm	L mm		
3/8	14,6	37	5	009200270
7/16	16,5	37	5	009200272
1/2	19,0	37	5	009200273
9/16	20,3	37	5	009200274
5/8	22,8	37	5	009200276
11/16	25,0	37	5	009200277
3/4	26,5	38	5	009200279
13/16	29,0	38	5	009200281
7/8	30,0	40	5	009200282
15/16	32,8	42	5	009200284
1	35,0	42	5	009200285
1.1/16	36,5	43	5	009200287
1.1/8	39,0	43	5	009200289
1.1/4	42,8	46	5	009200292



920A-AS/SB11
3/8-7/16-1/2-9/16-5/8
11/16-3/4-13/16-7/8
15/16-1

1 009200295

920AS

chiavi a bussola a mano
bocca poligonale

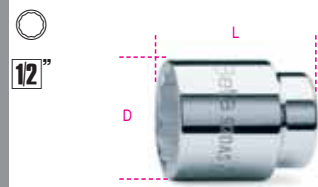

mm	D mm	L mm		
3/8	14,9	38	5	009200201
7/16	16,1	38	5	009200202
1/2	18,7	38	5	009200203
9/16	20,1	38	5	009200204
5/8	22,7	38	5	009200206
19/32	21,5	38	5	009200207
11/16	25,3	39	5	009200208
3/4	26,6	39	5	009200209
25/32	27,8	40	5	009200210
13/16	28,8	40	5	009200211
7/8	29,9	41	5	009200212
15/16	32,2	43	5	009200214
1	34,2	45	5	009200216
1.1/16	36,2	46	5	009200217
1.1/8	38,6	48	5	009200218
1.3/16	40,2	48	5	009200219
1.1/4	42,3	49	5	009200220



920AS/SB11
3/8-7/16-1/2-9/16-5/8
11/16-3/4-13/16-7/8
15/16-1

1 009200225

920AS/L

chiavi a bussola a mano lunghe
bocca poligonale



	D mm	L mm		
1/2	19,0	77	2	009200352
9/16	20,3	77	2	009200353
5/8	22,8	77	2	009200355
11/16	25,0	77	2	009200357
3/4	26,5	77	2	009200358
13/16	29,0	77	2	009200360
7/8	30,0	77	2	009200361
15/16	32,8	77	2	009200362
1	35,0	77	2	009200363
1.1/16	36,5	77	2	009200364
1.1/8	37,8	77	2	009200365



920ASL/SB11 1 009200369
1/2-9/16-5/8-11/16
3/4-13/16-7/8-15/16
1-1.1/8-1.1/16

920FTX

chiavi a bussola a mano per viti
con testa a profilo Torx®



	D mm	L mm		
E10	13,2	36	5	009200380
E12	15,0	37	5	009200381
E14	16,3	37	5	009200382
E16	18,8	37	5	009200383
E18	20,4	37	5	009200384
E20	22,9	37	5	009200385
E22	25,0	37	5	009200387
E24	26,5	40	5	009200388



920FTX/SB6 1 009200390
E10-E12-E14
E16-E18-E20



920FTX/C8 1 009200391
E10-E12-E14-E16
E18-E20-E22-E24
270X120X45 mm - 1050 g

920FTX/L

chiavi a bussola a mano lunghe
per viti con testa a profilo Torx®



	D mm		
E10	13,2	5	009200400
E12	15,0	5	009200401
E14	16,3	5	009200402
E16	18,8	5	009200403
E18	20,4	5	009200404
E20	22,9	5	009200405



920FTX/LSB6 1 009200409
E10-E12-E14
E16-E18-E20

920LP

chiavi a bussola a giravite
per viti con intaglio



SxA mm	D mm		
1x5,5	22,5	5	009200452
1,2x6,5	22,5	5	009200453
1,2x8	22,5	5	009200454
1,6x9	22,5	5	009200456
2x12	22,5	5	009200458

920PH

chiavi a bussola a giravite
per viti con impronta a croce Phillips®



PH	D mm		
1	22,5	5	009200471
2	22,5	5	009200472
3	22,5	5	009200473
4	22,5	5	009200474

920LH/SB7

chiavi a bussola a giravite
per viti con impronta a croce Phillips®



920LH/SB7 1 009200478
920LP 1,2x6,5 - 1,2x8
1,6x9 - 2X12 mm
920PH PH2 - PH3 - PH4

920PE

chiavi a bussola
maschio esagonale

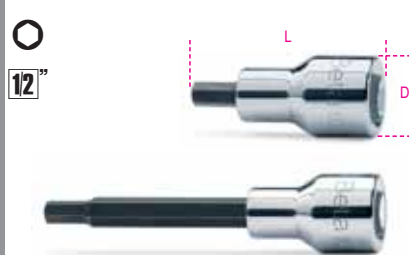

mm	D mm	L mm		
3	22,5	58	5	009200410
4	22,5	58	5	009200412
5	22,5	58	5	009200414
5L	22,5	100	5	009200415
6	22,5	58	5	009200417
6L	22,5	100	5	009200418
7	22,5	58	5	009200420
7L	22,5	100	5	009200421
8	22,5	58	5	009200423
8L	22,5	100	5	009200424
9	22,5	58	5	009200425
10	22,5	58	5	009200428
10L	22,5	140	5	009200429
12	23,0	58	5	009200432
14	23,0	58	5	009200434
17	29,5	60	5	009200437
19	29,5	60	5	009200439



920PE/SB9 1 009200441
4-5-6-8-10 mm
5L-6L-8L-10L mm



920PE/C10 1 009200443
4-5-6-7-8-10
12-14-17-19 mm
270X120X45 mm - 1450 g

920PE/LS4

serie di 4 chiavi 920PE



6L-7L-8L-10L 1 009200442

920PE/AS

chiavi a bussola
maschio esagonale



	D mm	L mm		
1/8	22,5	58	2	009200460
3/16	22,5	58	2	009200461
1/4	22,5	58	2	009200463
1/2	22,5	60	2	009200465
3/4	22,5	60	1	009200468

920BP

chiavi a bussola maschio esagonale
con estremità sferica

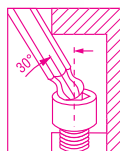

mm	L mm		
5L	100	5	009200490
5XL	240	1	009200495
6L	100	5	009200491
6XL	240	1	009200496
7L	100	5	009200492
8L	100	5	009200493
8XL	240	1	009200497
10L	140	5	009200494



920BP/SB8		1	009200500
5L-6L-7L-8L-10L mm			
5XL-6XL-8XL mm			

920ME

chiavi a bussola
maschio esagonale



mm	D mm		
5	21	5	009200505
6	21	5	009200506
7	21	5	009200507
8	21	5	009200508
10	23	5	009200510
12	24	5	009200512
14	24	5	009200514
17	24	5	009200517



920ME/SB7		1	009200519
5-6-8-10-12-14-17 mm			



920ME/C7		1	009200518
5-6-8-10-12-14-17 mm			
250X100X35 mm			1360 g

920TX

chiavi a bussola maschio
per viti con impronta Torx®



	D mm	L mm		
T20	22,5	58	5	009200520
T25	22,5	58	5	009200521
T27	22,5	58	5	009200522
T30	22,5	58	5	009200523
T40	22,5	58	5	009200524
T40L	22,5	120	3	009200535
T45	22,5	58	5	009200525
T45L	22,5	120	3	009200537
T50	22,5	58	5	009200526
T55	23,0	58	3	009200527
T55L	23,0	140	3	009200539
T60	23,0	58	3	009200528
T70L	23,0	120	3	009200541



920TX/SB9		1	009200532
T20-T25-T27-T30			
T40-T45-T50-T55-T60			

12"



920TX/C9		1	009200546
T20-T25-T27-T30-T40			
T45-T50-T55-T60			
270X120X45 mm			1200 g

920TX/LS4

serie di 4 chiavi 920TX

12"



40L-45L-55L-70L	1	009200544
-----------------	---	-----------

920RTX

chiavi a bussola maschio per viti
con impronta Tamper Resistant Torx®

12"



T20	5	009200370
T25	5	009200371
T27	5	009200372
T30	5	009200373
T40	5	009200374

12"



920RTX/SB5		1	009200378
T20-T25-T27-T30-T40			

920XZN

chiavi a bussola maschio
a profilo XZN®

12"

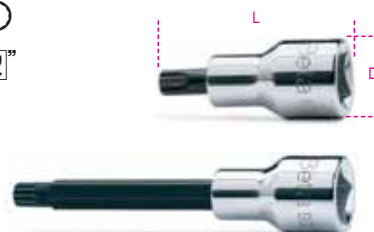

	D mm	L mm		
M4	22,5	58	5	009200559
M5	22,5	58	5	009200560
M6	22,5	58	5	009200561

	D mm	L mm		
M6L	22,5	100	3	009200562
M8	22,5	58	5	009200563
M8L	22,5	100	3	009200564
M9	22,5	58	3	009200582
M9L	22,5	100	3	009200583
M10	22,5	58	3	009200565
M10L	22,5	100	3	009200566
M12	22,5	58	3	009200568
M12L	22,5	100	3	009200569
M14	23,0	58	3	009200571
M14L	23,0	100	3	009200572
M16	23,0	58	3	009200573

12"

920XZN/SB7
M4-M5-M6-M8
M10-M12-M14

1 009200579

12"

920XZN/SB12
M5-M6-M8-M10-M12
M14-M16-M6L-M8L
M10L-M12L-M14L

1 009200577

12"

920XZN/LS5
M6L-M8L-M10L
M12L-M14L

1 009200578

920ES

chiavi a bussola per viti con impronta esascalata

12"

UNI 9326

Ø mm	L mm		
7	(6R) 58	5	009200587
7XL	(6R) 240	1	009200607
9	(8R) 58	5	009200589
9XL	(8R) 240	1	009200609
10	(8S) 58	5	009200590
10XL	(8S) 240	1	009200610
11	(10R) 58	5	009200591
11XL	(10R) 240	1	009200611
12L	(10S) 100	3	009200592
12XL	(10S) 240	1	009200612
14L	(12S) 100	3	009200594
14XL	(12S) 240	1	009200614
16L	(14R) 100	3	009200596
16XL	(14R) 240	1	009200616

12"

920ES/SB7
7-9-10-11-12L-14L-16L

1 009200598

920/15

raccordo con attacco quadro femmina 1/2" e maschio 3/8"

12"

UNI/ISO 3316 DIN 3123

□	■	L mm		
1/2	3/8	42	5	009200810

920/16

raccordo con attacco quadro femmina 1/2" e maschio 3/4"

12"

UNI/ISO 3316 DIN 3123

□	■	L mm		
1/2	3/4	46	5	009200814

920/20 - 920/21 - 920/22

prolunghe con attacchi quadri maschio e femmina 1/2"

12"

UNI/ISO 3316 DIN 3123

	L mm	D mm		
920/20	75	22	5	009200818
920/21	125	22	5	009200822
920/22	255	22	5	009200826

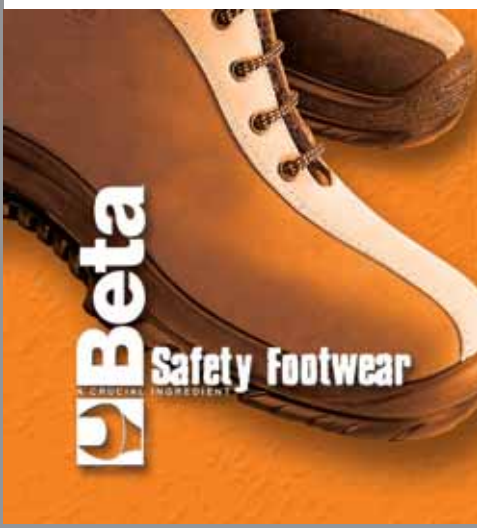

920AN

prolunghe con attacchi quadri maschio e femmina 1/2" angolari

12"

UNI/ISO 3316 DIN 3123

	L mm	D mm		
920AN/50	50	22	5	009200833
920AN/125	125	22	5	009200834
920AN/250	250	22	3	009200835
920AN/375	375	22	3	009200836

920MQ/21

prolunga quadro maschio e femmina 1/2"

12"

EN 60900

L mm	D mm		
135	28	2	009200804

920MQ/22

prolunga quadro maschio e femmina 1/2"

12"

EN 60900

L mm	D mm		
264	30	2	009200805

920/25

snodo con attacchi quadri maschio e femmina 1/2"

12"

UNI/ISO 3316 DIN 3123

L mm	D mm		
75	27	5	009200830

920/35A

quadro maschio 1/2" snodato con impugnatura

12"

UNI/ISO 3315 DIN 3122

L mm			
285		3	009200846

920M/35

quadro maschio 1/2" snodato
con impugnatura in metallo



UNI/ISO 3315 DIN 3122

L
mm
380 2 009200845

920M/35L

quadro maschio 1/2" snodato
con impugnatura in metallo, lungo



L
mm
600 1 009200843



È assolutamente necessario applicare
il carico di torsione adeguatamente
e progressivamente per evitare rotture
o danni accidentali.

920/36A

quadro maschio 1/2" snodato
con impugnatura



UNI/ISO 3315 DIN 3122

L
mm
408 2 009200847

920/40

quadro maschio 1/2"
snodato a T



L
mm
490 2 009200850

920/42

quadro maschio 1/2"
con spina scorrevole



UNI/ISO 3315 DIN 3122

L
mm
305 5 009200854

920/44

quadro maschio 1/2"
ad angolo



UNI/ISO 3315 DIN 3122

L
mm
230 3 009200858

920MQ/T

quadro maschio 1/2", a T

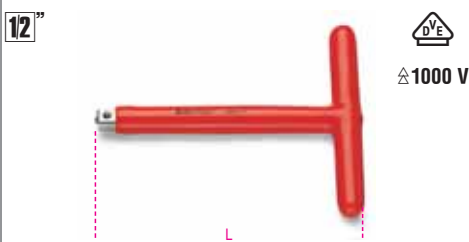

EN 60900

L
mm
200 2 009200807

920/46

quadro maschio 1/2"
con manovella



UNI/ISO 3315 DIN 3122

L
mm
385 1 009200862

920/50

cricchetto semplice
con attacco quadro scorrevole 1/2"
meccanismo a 72 denti



UNI/ISO 3315 DIN 3122

L D A
mm mm mm
275 40 42 3 009200871

920/50F

cricchetto semplice
con attacco quadro femmina 1/2"
meccanismo a 72 denti



UNI/ISO 3315 DIN 3122

L D A
mm mm mm
275 40 27 2 009200889

920/55

cricchetto reversibile
con attacco quadro maschio 1/2"
meccanismo a 72 denti



UNI/ISO 3315 DIN 3122

L D A
mm mm mm
275 40 43 3 009200882

920/55Q

cricchetto reversibile
con attacco quadro maschio 1/2"
meccanismo a 48 denti



UNI/ISO 3315 DIN 3122

L D A
mm mm mm
275 40 43 3 009200885

920/55X

cricchetto reversibile
con attacco quadro maschio 1/2"
meccanismo a 72 denti



UNI/ISO 3315 DIN 3122

L D A
mm mm mm
200 30 33 3 009200895

920/55LC

cricchetto reversibile
con attacco quadro maschio 1/2"
"Locking System"
meccanismo a 72 denti

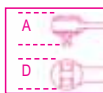

UNI/ISO 3315 DIN 3122

L mm	D mm	A mm	
275	40	43	2 009200896

920M/55

cricchetto reversibile
con attacco quadro maschio 1/2"
con impugnatura in metallo

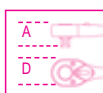

L mm	D mm	A mm	
253	38	35	1 009200893

920MQ/55A

cricchetto reversibile
con attacco quadro maschio 1/2"
con sistema di bloccaggio bussola



EN 60900

L mm	D mm	A mm	
240	50	89	1 009200809

920/56A

cricchetto reversibile snodato
con attacco quadro maschio 1/2"
meccanismo a 72 denti



L mm	D mm	A mm	
315	40	43	1 009200911

920M/56

cricchetto reversibile snodato
con attacco quadro maschio 1/2"
con impugnatura in metallo



L mm	D mm	A mm	
330	38	35,7	2 009200894

920.../C11

11 chiavi a bussola
e 2 accessori



920A/C11		
1	009200921	

920A		
920A	10 - 12 - 13 - 14 - 15 - 16 17 - 18 - 19 - 21 - 22 mm	
920/22	255 mm	
920/50		
	335x145x60 mm - 2530 g	

920B/C11		
1	009200922	

920B		
920B	10 - 12 - 13 - 14 - 15 - 16 17 - 18 - 19 - 21 - 22 mm	
920/22	255 mm	
920/50		
	335x145x60 mm - 2500 g	

920.../C12...

12 chiavi a bussola
e 5 accessori



920A/C12X		
1	009200933	

920A		
920A	10 - 11 - 12 - 13 - 14 - 17 - 19 22 - 24 - 27 - 30 - 32 mm	
920/21	125 mm	
920/22	255 mm	
920/25		
920/42		
920/55		
	420x185x60 mm - 4180 g	

920A/C12		
1	009200931	

920A		
920A	10 - 11 - 12 - 13 - 14 - 17 - 19 22 - 24 - 27 - 30 - 32 mm	
920/21	125 mm	
920/22	255 mm	
920/25		
920/42		
920/50		
	420x185x60 mm - 4180 g	

920B/C12X		
1	009200934	

920B		
920B	10 - 11 - 12 - 13 - 14 - 17 - 19 22 - 24 - 27 - 30 - 32 mm	
920/21	125 mm	
920/22	255 mm	
920/25		
920/42		
920/55		
	420x185x60 mm - 4050 g	

920B/C12		
1	009200932	

920B		
920B	10 - 11 - 12 - 13 - 14 - 17 - 19 22 - 24 - 27 - 30 - 32 mm	
920/21	125 mm	
920/22	255 mm	
920/25		
920/42		
920/50		
	420x185x60 mm - 4050 g	

920.../C20...

20 chiavi a bussola
e 5 accessori

12"



1 009200950

920A 10 - 11 - 12 - 13 - 14 - 15 - 16
17 - 18 - 19 - 20 - 21 - 22 - 23
24 - 26 - 27 - 28 - 30 - 32 mm

920/21 125 mm
920/22 255 mm
920/25
920/42
920/55

420x185x60 mm - 5100 g

1 009200948

920A 10 - 11 - 12 - 13 - 14 - 15 - 16
17 - 18 - 19 - 20 - 21 - 22 - 23
24 - 26 - 27 - 28 - 30 - 32 mm

920/21 125 mm
920/22 255 mm
920/25
920/42
920/50

420x185x60 mm - 5130 g

1 009200955

920A 10 - 11 - 12 - 13 - 14 - 15 - 16
17 - 18 - 19 - 20 - 21 - 22 - 23
24 - 26 - 27 - 28 - 30 - 32 mm

920/21 125 mm
920/22 255 mm
920/25
920/42
920/55Q

420x185x60 mm - 5100 g

1 009200949

920B 10 - 11 - 12 - 13 - 14 - 15 - 16
17 - 18 - 19 - 20 - 21 - 22 - 23
24 - 26 - 27 - 28 - 30 - 32 mm

920/21 125 mm
920/22 255 mm
920/25
920/42
920/50

420x185x60 mm - 5080 g

920B/C20X 1 009200951

920B 10 - 11 - 12 - 13 - 14 - 15 - 16
17 - 18 - 19 - 20 - 21 - 22 - 23
24 - 26 - 27 - 28 - 30 - 32 mm

920/21 125 mm
920/22 255 mm
920/25
920/42
920/55

420x185x60 mm - 5050 g

920.../C21...

21 chiavi a bussola
e 6 accessori

12"



920A/C21 1 009200952

920A 10 - 11 - 12 - 13 - 14 - 15 - 16
17 - 18 - 19 - 20 - 21 - 22 - 23
24 - 25 - 26 - 27 - 28 - 30 - 32 mm

920/21 125 mm
920/22 255 mm
920/25
920/42
920/46
920/50

420x280x60 mm - 6510 g

920A/C21X 1 009200983

920A 10 - 11 - 12 - 13 - 14 - 15 - 16
17 - 18 - 19 - 20 - 21 - 22 - 23
24 - 25 - 26 - 27 - 28 - 30 - 32 mm

920/21 125 mm
920/22 255 mm
920/25
920/42
920/46
920/55

420x280x60 mm - 6440 g

920B/C21 1 009200953

920B 10 - 11 - 12 - 13 - 14 - 15 - 16
17 - 18 - 19 - 20 - 21 - 22 - 23
24 - 25 - 26 - 27 - 28 - 30 - 32 mm

920/21 125 mm
920/22 255 mm
920/25
920/42
920/46
920/50

420x280x60 mm - 6430 g

920B/C21X 1 009200984

920B 10 - 11 - 12 - 13 - 14 - 15 - 16
17 - 18 - 19 - 20 - 21 - 22 - 23
24 - 25 - 26 - 27 - 28 - 30 - 32 mm

920/21 125 mm
920/22 255 mm
920/25
920/42
920/46
920/55

420x280x60 mm - 6380 g

920B/C30Q

30 chiavi a bussola poligonali
e 5 accessori

12"



920B/C30Q 1 009200975

920B 8 - 9 - 10 - 11 - 12 - 13 - 14
15 - 16 - 17 - 18 - 19 - 20 - 21
22 - 23 - 24 - 26 - 27 - 30 mm

920BL 12 - 13 - 14 - 17 - 19 - 21
22 - 24 - 27 - 30 mm
920/21 125 mm
920/22 255 mm
920/25
920/42
920/55Q

420x280x60 mm - 7600 g

Beta

920.../C33

20 chiavi a bussola poligonali
13 a giravite e 5 accessori

12"



920A/C33

1 009200985

	○ 920A	10 - 11 - 12 - 13 - 14 - 15 - 16 17 - 18 - 19 - 20 - 21 - 22 - 23 24 - 26 - 27 - 28 - 30 - 32 mm
	● 920LP	1,2x8 - 1,6x9 - 2x12 mm
	⊕ 920PH	PH2 - PH3 - PH4
	○ 920PE	4 - 5 - 6 - 8 - 10 - 12 - 14 mm
	920/21	125 mm
	920/22	255 mm
	920/25	
	920/42	
	920/55	

≡ 420x280x60 mm - 📦 6720 g

920/C37

37 chiavi a bussola poligonali
e 5 accessori

12"



920/C37

1 009200988

	○ 920B	10 - 11 - 12 - 13 - 14 - 15 - 16 17 - 18 - 19 - 20 - 21 - 22 - 23 24 - 26 - 27 - 28 - 30 - 32 mm
	○ 920AS	3/8 - 7/16 - 1/2 - 9/16 - 19/32 5/8 - 11/16 - 3/4 - 25/32 - 13/16 7/8 - 15/16 - 1 - 1.1/16 - 1.1/8 1.3/16 - 1.1/4
	920/21	125 mm
	920/22	255 mm
	920/25	
	920/42	
	920/55	

≡ 420x280x60 mm - 📦 7500 g

920AS/C15

15 chiavi a bussola poligonali
e 6 accessori

12"



920AS/C15

1 009200947

	○ 920AS	3/8 - 7/16 - 1/2 - 9/16 - 5/8 - 11/16 3/4 - 13/16 - 7/8 - 15/16 - 1 1.1/16 - 1.1/8 - 1.3/16 - 1.1/4
	920/21	125 mm
	920/22	255 mm
	920/25	
	920/42	
	920/46	
	920/50	

≡ 420x280x60 mm - 📦 5900 g

920AS/C10

10 chiavi a bussola poligonali
e 2 accessori

12"



920AS/C10

1 009200919

	○ 920AS	3/8 - 7/16 - 1/2 - 9/16 - 5/8 11/16 - 3/4 - 13/16 - 7/8 - 15/16
	920/22	255 mm
	920/50	

≡ 335x145x60 mm - 📦 2600 g

920AS/C17X

17 chiavi a bussola poligonali
e 5 accessori

12"



920AS/C17X

1 009200942

	○ 920AS	3/8 - 7/16 - 1/2 - 9/16 - 19/32 - 5/8 11/16 - 3/4 - 25/32 - 13/16 - 7/8 15/16 - 1 - 1.1/16 - 1.1/8 - 1.3/16 - 1.1/4
	920/21	125 mm
	920/22	255 mm
	920/25	
	920/42	
	920/55	

≡ 420x185x60 mm - 📦 4800 g



920AS/MBM-C21

16 chiavi a bussola poligonali
e 5 accessori
per manutenzioni aeronautiche

12"



920AS/MBM-C21

1 009200944

	920AS	3/8 - 7/16 - 1/2 - 9/16 19/32 - 5/8 - 11/16 - 3/4 25/32 - 13/16 - 7/8 - 15/16 1 - 1.1/16 - 1.3/16 - 1.1/4
	920M/55	
	920/21	125 mm
	920/22	255 mm
	920/25	
	920/42	
		420x185x60 mm - 5000 g

920MQ/C16

9 chiavi a bussola esagonali
3 chiavi a T maschio esagonale
e 4 accessori

12"

1000 V



EN 60900

920MQ/C16

1 009200918

	920MQ/A	10 - 11 - 12 - 13 - 14 17 - 19 - 22 - 24 mm
	920MQ/21	135 mm
	920MQ/22	264 mm
	920MQ/55A	
	920MQ/T	
	951MQ	5 - 6 - 8 mm
		420x280x60 mm - 5500 g

928B

chiavi a bussola a mano
bocca poligonale

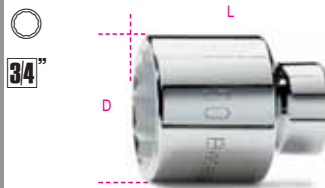

mm	D mm	L mm	
19	29,2	50	5 009280119
22	31,3	53	5 009280122
23	33,3	53	5 009280123
24	34,5	53	5 009280124
26	36,8	55	5 009280126
27	38,0	56	5 009280127
28	39,0	57	5 009280128
29	40,2	58	5 009280129
30	41,5	58	5 009280130
32	44,3	60	5 009280132
33	45,8	60	3 009280133
34	46,8	60	3 009280134
35	48,1	62	3 009280135
36	49,5	64	3 009280136
38	52,0	68	3 009280138
41	56,0	71	3 009280141
46	62,3	75	3 009280146
50	67,4	80	3 009280150
55	73,7	84	1 009280155
60	80,0	87	1 009280160

920TX/C17

6 inserti per avvitatori
6 chiavi a bussola
5 chiavi a bussola maschio
e 4 accessori, per viti con impronta Torx®

12"



920TX/C17

1 009200989

	861TX	T8 - T10 - T15 - T20 - T25 - T27
	897	
	920TX	T27 - T30 - T40 - T45 - T50
	920FTX	E10 - E12 - E14 - E16 - E18 - E20
	920/20	75 mm
	920/22	255 mm
	920/55	
		420x185x60 mm - 2900 g

928A

chiavi a bussola a mano
bocca esagonale



mm	D mm	L mm	
19	29,2	50	5 009280019
22	31,3	53	5 009280022
23	33,3	53	5 009280023
24	34,5	53	5 009280024
26	36,8	55	5 009280026
27	38,0	56	5 009280027
28	39,0	57	5 009280028
29	40,2	58	5 009280029
30	41,5	58	5 009280030
32	44,3	60	5 009280032
33	45,8	60	3 009280033
34	46,8	60	3 009280034
35	48,1	62	3 009280035
36	49,5	64	3 009280036
38	52,0	68	3 009280038
41	56,0	71	3 009280041
46	62,3	75	3 009280046
50	67,4	80	3 009280050
55	73,7	84	1 009280055
60	80,0	87	1 009280060

928AS

chiavi a bussola a mano
bocca esagonale

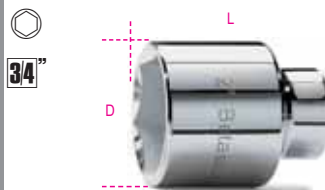

mm	D mm	L mm	
7/8	32,0	53	1 009280202
15/16	34,5	53	1 009280203
1	36,2	55	1 009280204
1.1/16	38,0	56	1 009280205
1.1/8	40,2	58	1 009280206
1.1/4	44,2	60	1 009280208
1.5/16	45,8	60	1 009280209
1.3/8	48,1	62	1 009280210
1.7/16	49,5	64	1 009280211
1.1/2	52,0	68	1 009280212
1.5/8	56,0	71	1 009280214
1.11/16	58,8	74	1 009280215
1.13/16	62,3	75	1 009280217
1.7/8	65,0	78	1 009280218
2	68,3	80	1 009280219
2.1/16	71,5	83	1 009280220

928ME

chiavi a bussola
maschio esagonale



3/4"



mm	L mm		
14	75	2	009280514
17	75	2	009280517
19	75	2	009280519
22	75	2	009280522

928/15

raccordo con attacco quadro
femmina 3/4" e maschio 1/2"

3/4"



□	■	L mm	
3/4	1/2	51,5	5 009280801

928/16

raccordo con attacco quadro
femmina 3/4" e maschio 1"

3/4"



□	■	L mm	
3/4	1"	65	5 009280807

928/21 - 928/22

prolunghe con attacchi quadri
maschio e femmina 3/4"

3/4"



	L mm	D mm	
928/21	200	34	3 009280815
928/22	380	34	3 009280825

928/25

snodo con attacchi quadri maschio
e femmina 3/4"

3/4"



UNI/ISO 3316 DIN 3123

L mm	D mm		
108	40	1	009280830

928/36A

quadro maschio 3/4" snodato
con impugnatura

3/4"



L mm		
545	1	009280844

928/42

quadro maschio 3/4"
con spina scorrevole

3/4"



L mm		
450	3	009280850

928/55

cricchetto reversibile
con attacco quadro maschio 3/4"
meccanismo a 72 denti

3/4"



L mm	D mm	A mm	
510	58	59	2 009280862

928.../C9SN

9 chiavi a bussola esagonali
e 5 accessori

3/4"



928A/C9SN 1 009280962

	928A	22-24-27-30-32-36 41-46-50 mm
	928/21	200 mm
	928/22	380 mm
	928/25	
	928/42	
	928/55	

530x220x80 mm - 12,0 kg

928B/C9SN 1 009280966

	928B	22-24-27-30-32-36 41-46-50 mm
	928/21	200 mm
	928/22	380 mm
	928/25	
	928/42	
	928/55	

530x220x80 mm - 12,2 kg

928.../C11

11 chiavi a bussola
e 7 accessori

3/4"



928A/C11 1 009280954

	928A	22 - 24 - 27 - 30 - 32 - 36 41 - 46 - 50 - 55 - 60 mm
	928/15	□ 3/4 - ■ 1/2
	928/16	□ 3/4 - ■ 1"
	928/21	200 mm
	928/22	380 mm
	928/36A	
	928/42	
	928/55	

530x220x95 mm - 16,7 kg



928B/C11 1 009280958

- 928B 22 - 24 - 27 - 30 - 32 - 36
41 - 46 - 50 - 55 - 60 mm
- 928/15 □ 3/4 - ■ 1/2
- 928/16 □ 3/4 - ■ 1"
- 928/21 200 mm
- 928/22 380 mm
- 928/36A
- 928/42
- 928/55

530x220x95 mm - 16,5 kg

928AS/C8SN

8 chiavi a bussola esagonali e 5 accessori



928AS/C8SN 1 009280967

- 928AS 7/8-15/16-1.1/8-1.5/16
1.1/2-1.11/16-1.7/8-2.1/16
- 928/21 200 mm
- 928/22 380 mm
- 928/25
- 928/42
- 928/55

530x220x80 mm - 12,5 kg

929

chiavi a bussola a mano bocca esagonale

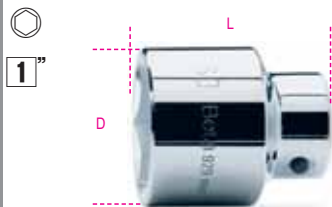

UNI/ISO 2725 DIN 3124

mm	D mm	L mm	
36	49,5	65	1 009290036
41	56,0	70	1 009290041
46	62,0	75	1 009290046
50	67,5	80	1 009290050
55	74,0	85	1 009290055
60	80,0	90	1 009290060
65	86,0	95	1 009290065
70	92,0	100	1 009290070
75	99,0	110	1 009290075
80	106,0	120	1 009290080

929/15

raccordo con attacco quadro femmina 1" e maschio 3/4"



UNI/ISO 3316 DIN 3123

□	■	L mm	
1"	3/4	65	2 009290801

929/21 - 929/22

prolunghe con attacchi quadri maschio e femmina 1"

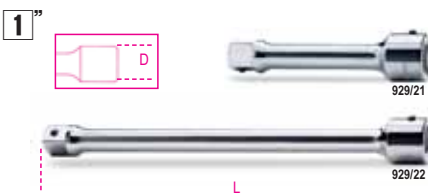

UNI/ISO 3316 DIN 3123

	L mm	D mm	
929/21	200	47	1 009290815
929/22	400	47	1 009290825

929/42

quadro maschio 1" con spina scorrevole



UNI/ISO 3315 DIN 3122

L mm	
535	1 009290850

929/55

cricchetto reversibile con attacco quadro maschio 1" meccanismo a 72 denti



UNI/ISO 3315 DIN 3122

L mm	D mm	A mm	
770	62	63	1 009290860

929/C8

8 chiavi a bussola esagonali e 5 accessori



929/C8 1 009290925

- 929 46 - 50 - 55 - 60 - 65
70 - 75 - 80 mm
- 929/15 □ 1" - ■ 3/4
- 929/21 200 mm
- 929/22 400 mm
- 929/42
- 929/55

560x290x12 mm - 29 kg

900/R55



900/R55 x 900/55 1 009000871

900M/R55



900M/R55 x 900M/55 1 009000888

900M/R56



900M/R56 x 900M/56 1 009000889

910/R55



910/R55 x 606/6-606/10-612
666/6-666/10-910/55 1 009100879



910M/R55



910M/R55
x 910M/55-910M/56

1 009100888

910/R55Q



910/R55Q
x 910/55Q

1 009100877

920/R50



920/R50
x 614/50-667/20-667/30
920/50

1 009200866

920/R55



920/R55
x 606/20-606/30-666/20-666/30
920/55-920/56A

1 009200879

920M/R55



920M/R55
x 920M/55-920M/56

1 009200888

920/R55Q



920/R55Q
x 920/55Q

1 009200877

920/R55X



920/R55X
x 606/10X-612X
666/10X-920/55X

1 009200878

920/R55LC



920/R55LC
x 920/55LC "Locking System"

1 009200887

928/R55



928/R55
x 928/55

1 009280859

928/R55X



928/R55X
x 614X

1 009280858

929/R55



929/R55
x 929/55

1 009290859

930

chiavi a tubo doppie poligonali
serie pesante



UNI 6745

mm	L mm	
6x7	100	5 009300006
8x9	108	5 009300010
10x11	116	5 009300014
12x13	124	5 009300018
14x15	132	5 009300023
16x17	140	5 009300027
18x19	148	5 009300032
20x22	156	3 009300036
21x23	163	3 009300040
24x26	173	3 009300044
25x28	182	3 009300048
27x29	191	3 009300052
30x32	200	3 009300056



930/S8
6x7-8x9-10x11
12x13-14x15-16x17
18x19-20x22 mm

1 009300081

930/S12
6x7-8x9-10x11-12x13
14x15-16x17-18x19
20x22-21x23-24x26
25x28-30x32 mm

1 009300082

930/S13
6x7-8x9-10x11-12x13
14x15-16x17-18x19
20x22-21x23-24x26
25x28-27x29-30x32 mm

1 009300083



930/SP13
6x7-8x9-10x11-12x13
14x15-16x17-18x19
20x22-21x23-24x26
25x28-27x29-30x32 mm

1 009300084

930/SPV
1 009300095



930/C13
6x7-8x9-10x11-12x13
14x15-16x17-18x19
20x22-21x23-24x26
25x28-27x29-30x32 mm

1 009300098

932

chiavi a pipa doppie
esagonali-poligonali
cromate lucide

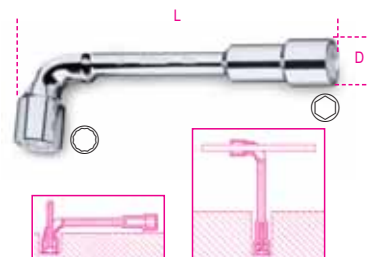

NF E 74.303

mm	D mm	L mm	
6x6	11,0	110	5 009320006
7x7	12,0	114	5 009320007
8x8	13,0	119	5 009320008

Ø mm	D mm	L mm		
9x9	14,5	125	5	009320009
10x10	16,0	131	5	009320010
11x11	17,0	137	5	009320011
12x12	18,0	144	5	009320012
13x13	19,0	152	5	009320013
14x14	21,0	160	5	009320014
15x15	22,5	174	5	009320015
16x16	24,0	185	5	009320016
17x17	25,0	197	5	009320017
18x18	26,5	211	5	009320018
19x19	28,0	218	5	009320019
20x20	30,0	222	5	009320020
21x21	30,5	231	5	009320021
22x22	32,0	247	3	009320022
23x23	33,5	255	3	009320023
24x24	34,5	266	3	009320024
25x25	36,0	278	3	009320025
26x26	37,0	289	3	009320026
27x27	38,5	299	3	009320027
28x28	39,0	310	3	009320028
30x30	42,0	332	3	009320030
32x32	45,0	353	3	009320032



1 009320080

932/S11

6-7-8-10-11-12
13-14-17-19-22 mm

932/S17 1 009320081

6-7-8-9-10-11-12
13-14-15-16-17
18-19-20-21-22 mm

932/S25 1 009320082

6-7-8-9-10-11-12-13
14-15-16-17-18-19
20-21-22-23-24-25
26-27-28-30-32 mm

933

chiavi a pipa doppie
esagonali
cromate lucide

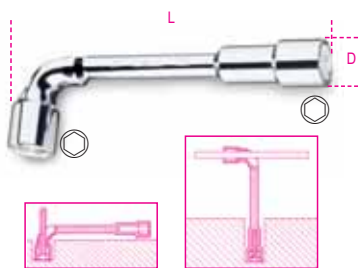

NF E 74.303

Ø mm	D mm	L mm		
6x6	11,0	110	5	009330006
7x7	12,0	114	5	009330007
8x8	13,0	119	5	009330008
9x9	14,5	125	5	009330009
10x10	16,0	131	5	009330010
11x11	17,0	137	5	009330011
12x12	18,0	144	5	009330012
13x13	19,0	152	5	009330013
14x14	21,0	160	5	009330014
15x15	22,5	174	5	009330015
16x16	24,0	185	5	009330016
17x17	25,0	197	5	009330017
18x18	26,5	211	5	009330018
19x19	28,0	218	5	009330019

Ø mm	D mm	L mm		
20x20	30,0	222	5	009330020
21x21	30,5	231	5	009330021
22x22	32,0	247	3	009330022
23x23	33,5	255	3	009330023
24x24	34,5	266	3	009330024
25x25	36,0	278	3	009330025
26x26	37,0	289	3	009330026
27x27	38,5	299	3	009330027
28x28	39,0	310	3	009330028
30x30	42,0	332	3	009330030
32x32	45,0	353	3	009330032



1 009330080

933/S11

6-7-8-10-11-12
13-14-17-19-22 mm

933/S17 1 009330081

6-7-8-9-10-11-12
13-14-15-16-17
18-19-20-21-22 mm

933/S25 1 009330082

6-7-8-9-10-11-12-13
14-15-16-17-18-19
20-21-22-23-24-25
26-27-28-30-32 mm

935

chiavi a tubo doppie
esagonali
serie leggera



UNI 6746 DIN 896

Ø mm	L mm		
6x7	100	5	009350105
8x9	110	5	009350111
10x11	120	5	009350115
12x13	130	5	009350117
14x15	140	5	009350126
16x17	150	5	009350128
18x19	160	5	009350131
20x22	170	3	009350138
21x23	180	3	009350141
24x26	190	3	009350144
25x28	200	3	009350150
27x29	210	3	009350153
30x32	220	3	009350156



1 009350181

935/S8

6x7-8x9-10x11
12x13-14x15-16x17
18x19-20x22 mm

935/S12 1 009350182

6x7-8x9-10x11
12x13-14x15-16x17
18x19-20x22-21x23
24x26-25x28-30x32 mm

935/S13 1 009350183

6x7-8x9-10x11
12x13-14x15-16x17
18x19-20x22-21x23
24x26-25x28-27x29
30x32 mm

937

chiavi a pipa doppie
esagonali-poligonali
cromate

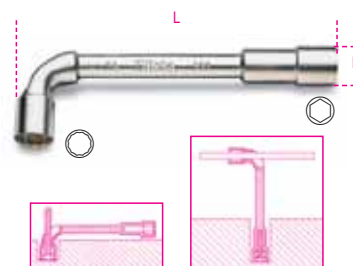

Ø mm	D mm	L mm		
6x6	11,0	110	5	009370006
7x7	12,0	114	5	009370007
8x8	13,0	119	5	009370008
9x9	14,5	125	5	009370009
10x10	16,0	131	5	009370010
11x11	17,0	137	5	009370011
12x12	18,0	144	5	009370012
13x13	19,0	152	5	009370013
14x14	21,0	160	5	009370014
15x15	22,5	174	5	009370015
16x16	24,0	185	5	009370016
17x17	25,0	197	5	009370017
18x18	26,5	211	5	009370018
19x19	28,0	218	5	009370019
20x20	30,0	222	5	009370020
21x21	30,5	231	3	009370021
22x22	32,0	247	3	009370022
23x23	33,5	255	3	009370023
24x24	34,5	266	3	009370024
25x25	36,0	278	3	009370025
26x26	37,0	289	3	009370026
27x27	38,5	299	3	009370027
28x28	39,0	310	3	009370028
30x30	42,0	332	3	009370030
32x32	45,0	353	3	009370032



937/S11	1	009370080
6-7-8-10-11-12 13-14-17-19-22 mm		
937/S17	1	009370081
6-7-8-9-10-11-12 13-14-15-16-17 18-19-20-21-22 mm		

940

spine di manovra per 930-935



	mm	L mm		
940/1	6÷13	100	5	009400001
940/2	14÷22	170	5	009400002
940/3	21÷32	290	5	009400003

942BM

chiavi a bussola esagonale
con impugnatura bimatériale
tipo corto



UNI 6750

mm	L mm	L1 mm		
4	186	70	10	009420613
5	186	70	10	009420614
5,5	186	70	10	009420615
6	186	70	10	009420616
7	186	70	10	009420617
8	197	70	5	009420618
9	197	70	5	009420619
10	197	70	5	009420620
11	197	70	5	009420621
12	203	70	5	009420622
13	203	70	5	009420623
14	203	70	5	009420624



942BM/S12	1	009420630
4-5-5,5-6-7-8-9 10-11-12-13-14 mm		

942BX

chiavi a bussola esagonale
con impugnatura bimatériale
tipo corto



UNI 6750

mm	L mm	L1 mm		
4	190	70	5	009420003
5	190	70	5	009420004
5,5	190	70	5	009420005
6	190	70	5	009420006
7	190	70	5	009420007
8	202	70	5	009420008
9	202	70	5	009420009
10	202	70	5	009420010
11	202	70	5	009420011
12	202	70	5	009420012
13	202	70	5	009420013
14	202	70	5	009420014



942BX/S12	1	009420030
4-5-5,5-6-7-8-9 10-11-12-13-14 mm		

943BM

chiavi a bussola esagonale
con impugnatura bimatériale
tipo lungo



UNI 6750

mm	L mm	L1 mm		
4	266	150	5	009430613
5	266	150	5	009430614
5,5	266	150	5	009430615
6	266	150	5	009430616
7	266	150	5	009430617
8	277	150	5	009430618
9	277	150	5	009430619
10	277	150	5	009430620
11	277	150	5	009430621
12	283	150	5	009430622
13	283	150	5	009430623
14	283	150	5	009430624



943BM/S12	1	009430630
4-5-5,5-6-7-8-9 10-11-12-13-14 mm		



943BM/D8	1	009430637
5-5,5-6-7-8-9-10-13 mm		

943BX

chiavi a bussola esagonale
con impugnatura bimatériale
tipo lungo



UNI 6750

mm	L mm	L1 mm		
4	270	150	5	009430003
5	270	150	5	009430004
5,5	270	150	5	009430005
6	270	150	5	009430006
7	270	150	5	009430007
8	282	150	5	009430008
9	282	150	5	009430009
10	282	150	5	009430010
11	282	150	5	009430011
12	282	150	5	009430012
13	282	150	5	009430013
14	282	150	5	009430014



943BX/S12	1	009430030
4-5-5,5-6-7-8-9 10-11-12-13-14 mm		



943BX/D6	1	009430026
5-6-7-8-10-13 mm		

943MQ

chiavi a bussola esagonale con impugnatura



EN 60900

mm	L mm	L1 mm	
5,5	233	125	2 009430962
6	233	125	2 009430963
7	240	125	2 009430964
8	240	125	2 009430965
10	252	125	2 009430967
13	257	125	2 009430968



943MQ/S6
5,5-6-7-8-10-13 mm 1 009430970

943FL

chiavi a bussola esagonale flessibili con impugnatura



mm	L mm	L1 mm	
5	265	150	5 009430304
5,5	265	150	5 009430305
6	265	150	5 009430306
7	265	150	5 009430307
8	265	150	5 009430308
10	290	175	5 009430310



943FL/S6
5-5,5-6-7-8-10 mm 1 009430320

950

chiavi a T semplici esagonali

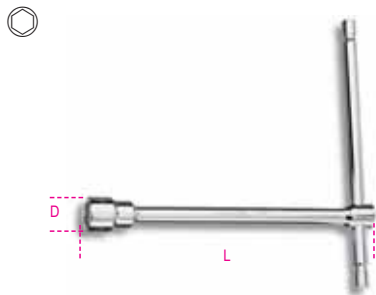

UNI 6742 DIN 3112

mm	L mm	D mm	
6	210	10,1	5 009500006
7	212	11,2	5 009500007
8	220	12,4	5 009500008
9	223	13,5	5 009500009
10	230	14,9	5 009500010
11	233	16,1	5 009500011
12	240	17,5	5 009500012
13	244	19,7	5 009500013
14	250	20,1	3 009500014
15	254	21,5	3 009500015
16	260	22,7	3 009500016
17	264	24,1	3 009500017
19	274	26,6	3 009500019
22	290	29,9	3 009500022
24	300	32,2	3 009500024
27	315	36,2	3 009500027



950/S9 7-8-10-11-12 13-14-17-19 mm	1 009500079
950/S14 6-7-8-9-10-11-12-13 14-15-16-17-19-22 mm	1 009500082

951

chiavi a T con tre estremità maschio esagonale



mm	L mm	L1 mm	
2	125	63	5 009510521
2,5	150	63	5 009510525
3	150	63	5 009510530
3,5	175	76	5 009510535
4	175	76	5 009510540
4,5	195	87	5 009510545
5	195	87	5 009510550
6	215	99	5 009510560
7	230	109	5 009510570
8	250	122	5 009510580
9	265	132	5 009510590

mm	L mm	L1 mm	
10	280	142	5 009510610
12	305	160	3 009510620
14	330	178	3 009510640

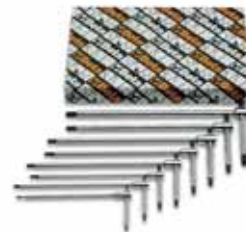

951/S8 2-2,5-3-3,5-4-4,5-5-6 mm	1 009510693
951/S14 2-2,5-3-3,5-4-4,5 5-6-7-8-9-10-12-14 mm	1 009510695



951/SP6 3-4-5-6-8-10 mm	1 009510696
951/SPV	1 009510697

951AS

chiavi a T con tre estremità maschio esagonale



	L mm	L1 mm	
3/32	125	63	2 009510750
7/64	150	63	2 009510751
1/8	150	63	2 009510752
9/64	175	76	2 009510753
5/32	175	76	5 009510754
3/16	195	86	5 009510755
7/32	215	99	5 009510757
1/4	230	109	5 009510758
5/16	250	122	5 009510759
3/8	280	142	5 009510760

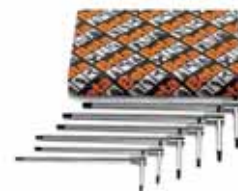

951AS/S6 5/32-3/16-7/32 1/4-5/16-3/8	1 009510770
--	-------------

Beta
SHOP
in Shop

951TX

chiavi a T con tre estremità maschio per viti con impronta Torx®

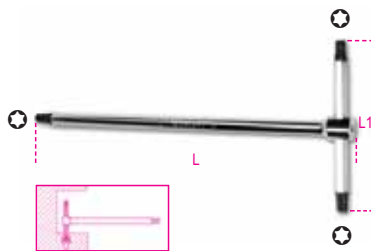

	L mm	L1 mm		
T8	125	63	5	009510808
T9	125	63	5	009510809
T10	150	63	5	009510810
T15	150	63	5	009510815
T20	175	76	5	009510820
T25	175	76	5	009510825
T27	195	87	5	009510827
T30	195	87	5	009510830
T40	215	99	5	009510840
T45	230	109	5	009510845
T50	250	122	5	009510850

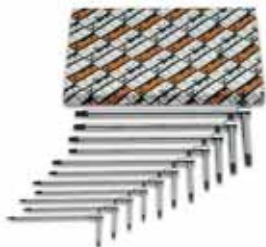

951TX/S11
T8-T9-T10-T15-T20-T25
T27-T30-T40-T45-T50

951QF

chiavi a T con tre estremità maschio esagonale
astina sfilabile e quadro femmina in testa

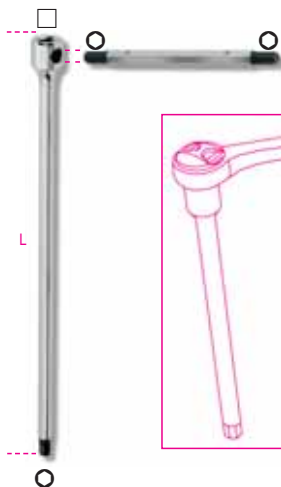

mm	□	L mm		
2,5	1/4	150	5	009510000
3	1/4	150	5	009510001
3,5	1/4	175	5	009510002
4	1/4	175	5	009510003
4,5	1/4	195	5	009510004
5	1/4	195	5	009510005

mm	□	L mm		
6	3/8	215	5	009510006
7	3/8	230	5	009510007
8	3/8	250	5	009510008
9	3/8	265	5	009510009
10	1/2	280	5	009510010
12	1/2	305	3	009510012
14	1/2	330	3	009510014

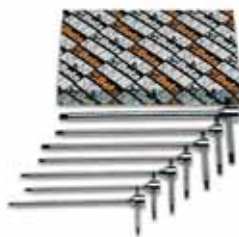

951QF/S7
2,5-3-3,5-4-4,5-5-6 mm

951QF/S13
2,5-3-3,5-4-4,5
5-6-7-8-9-10-12-14 mm



951QF/SP6
3-4-5-6-8-10 mm

951/SPV

951MQ

chiavi a T maschio esagonale



EN 60900

mm	L mm		
4	165	2	009510704
5	170	2	009510705
6	168	2	009510706
8	165	2	009510708

952

chiavi a T con bussola esagonale snodata

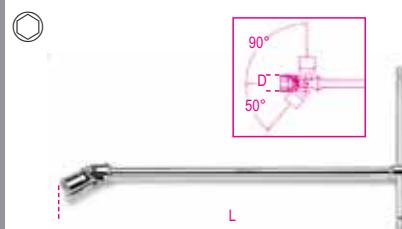

UNI 6743

mm	D mm	L mm		
6	9,5	395	5	009520006
7	10,7	395	5	009520007
8	12,1	395	5	009520008
9	13,2	395	5	009520009
10	14,6	400	5	009520010
11	15,8	400	5	009520011
12	17,0	400	5	009520012
13	18,7	432	5	009520013
14	19,7	432	5	009520014
15	20,9	450	3	009520015
16	22,0	450	3	009520016
17	23,4	450	3	009520017
18	24,7	450	3	009520018
19	26,0	500	3	009520019
20	27,4	500	3	009520020
21	28,5	500	3	009520021
22	29,7	500	3	009520022
24	32,4	500	3	009520024



952/S7
8-10-11-13-14-17-19 mm

952/S18
6-7-8-9-10-11-12
13-14-15-16-17
18-19-20-21-22-24 mm

952AS

chiavi a T con bussola esagonale snodata

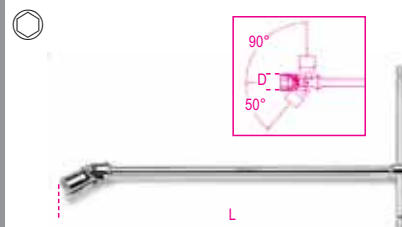

mm	D mm	L mm		
1/4	10,7	395	2	009520256
5/16	12,1	395	2	009520258
3/8	14,6	400	2	009520260
7/16	17,0	400	2	009520261
1/2	18,7	432	2	009520263
9/16	20,9	450	2	009520264
5/8	22,0	450	2	009520266
11/16	24,7	450	2	009520267
3/4	27,4	500	2	009520269
13/16	28,0	500	2	009520271
7/8	32,4	500	2	009520272

Beta



952L

chiavi a T con bussola esagonale
snodata, tipo lungo

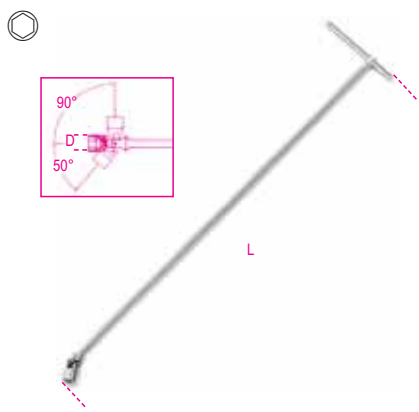

mm	D mm	L mm		
10	14,6	930	1	009520410
12	17,0	930	1	009520412
13	18,7	1100	1	009520413
14	19,7	1100	1	009520414
15	20,9	1100	1	009520415
16	22,0	1100	1	009520416
17	23,4	1100	1	009520417
18	24,7	1100	1	009520418
19	26,0	1100	1	009520419
22	29,7	1100	1	009520422

952FTX

chiavi a T con bussola snodata
per viti con testa a profilo Torx®

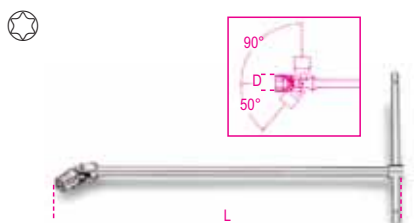

	D mm	L mm		
E6	8	392	2	009520106
E7	9	392	2	009520107
E8	10	395	2	009520108
E10	13	400	2	009520110
E12	15	440	2	009520112
E14	17	490	2	009520114
E16	19	490	2	009520116
E18	21	490	2	009520118
E20	23	490	2	009520120



952FTX/S9	1	009520141
E6-E7-E8-E10-E12		
E14-E16-E18-E20		

953

chiavi a T con maschio esagonale
snodato

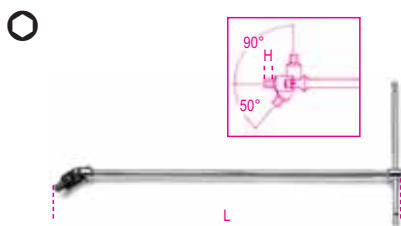

UNI 6754

mm	H mm	L mm		
3	5	395	5	009530130
3,5	6	395	5	009530135
4	6	395	5	009530140
4,5	7	395	5	009530145
5	7	395	5	009530150
6	9	400	5	009530160
7	10	425	5	009530170
8	11	425	5	009530180
10	13	440	5	009530200



953/S9
3-3,5-4-4,5
5-6-7-8-10 mm

1 009530301

953AS

chiavi a T con maschio esagonale
snodato

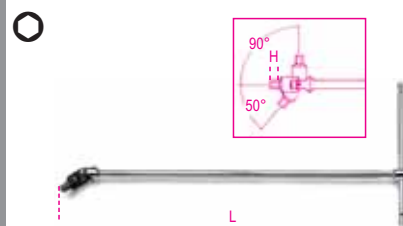

	H mm	L mm		
3/32	5	395	2	009530310
7/64	5	395	2	009530311
1/8	5	395	2	009530312
9/64	6	395	2	009530313
5/32	6	395	2	009530314
3/16	7	395	2	009530315
7/32	9	400	2	009530316

953L

chiavi a T con maschio esagonale
snodato, tipo lungo

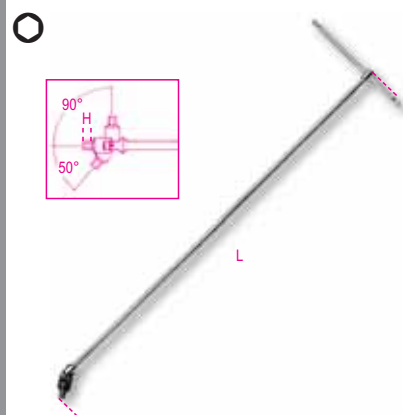

UNI 6754

mm	H mm	L mm		
3	5	925	1	009530403
4	6	925	1	009530404
5	7	925	1	009530405
6	9	930	1	009530406
8	11	1095	1	009530408
10	13	1095	1	009530410

953TX

chiavi a T con maschio snodato
per viti con impronta Torx®

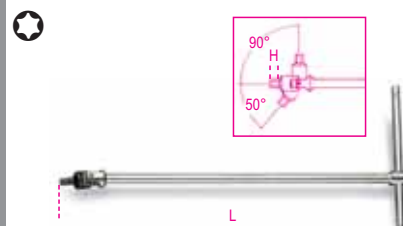

	H mm	L mm		
T20	11	396	2	009530020
T25	11	396	2	009530025
T27	11	396	2	009530027
T30	13	400	2	009530030
T40	13	400	2	009530040
T45	13	426	2	009530045
T50	14	442	2	009530050
T55	14	442	2	009530055



953TX/S8
T20-T25-T27-T30
T40-T45-T50-T55

1 009530060

955

chiave a tubo semplice
per candele d'accensione

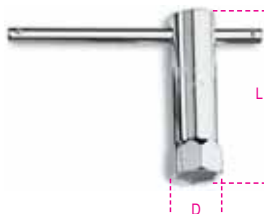

mm	D mm	L mm	
16 (5/8)	21	86	3 009550016
20,8 (13/16)	29	86	5 009550021

956C

chiavi a bussola
con attacco quadro femmina 1/2"
per candele d'accensione



ISO 11168

mm	D mm	L mm	
14 (9/16)	18,8	70	5 009560008
16 (5/8)	21,4	70	5 009560010
17,8 (11/16)	23,6	70	5 009560011
20,8 (13/16)	27,0	70	5 009560012

956E

chiavi a bussola
con attacco quadro femmina 3/8"
per candele d'accensione



ISO 11168

mm	D mm	L mm	
14 (9/16)	18,8	70	5 009560018
16 (5/8)	21,4	70	5 009560020
17,8 (11/16)	23,6	70	5 009560021
20,8 (13/16)	27,0	70	5 009560022

956L

chiavi a bussola poligonale
con attacco quadro femmina 1/2"
tipo lungo, per candele d'accensione



mm	D mm	L mm	
14 (9/16)	20,2	250	2 009560214
16 (5/8)	24	250	2 009560216
17,8 (11/16)	24	250	2 009560217
20,8 (13/16)	28,5	250	2 009560221

957

chiavi a T con bussola snodata
per candele d'accensione

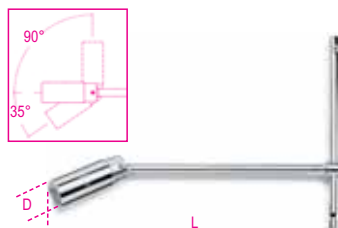

ISO 11168

mm	D mm	L mm	
16 (5/8)	21,4	275	3 009570000
20,8 (13/16)	27,0	275	3 009570001

959

chiavi a T con bussola snodata
tipo normale, per candele d'accensione

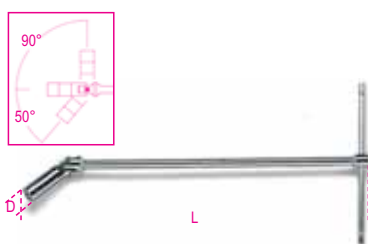

ISO 11168

mm	D mm	L mm	
14 (9/16)	18,8	483	3 009590009
16 (5/8)	21,4	483	3 009590010
20,8 (13/16)	27,0	527	3 009590011

959R

gommino e molla di ricambio
per 956C - 956E - 957 - 959

959R/14	956C/14-956E/14	3 009590223
959R/16	956C/16-956E/16 957/16-959/16	3 009590224
959R/17,8	956C/17,8-956E/17,8	3 009590225
959R/20,8	956C/20,8-956E/20,8 957/20,8-959/20,8-959L	3 009590226

960

chiavi a bussola
con attacco quadro femmina 1/2"
per iniettori motori Diesel

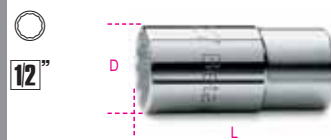

mm	D mm	L mm	
27	36,5	77	5 009600027

960A

chiavi a bussola
con attacco quadro femmina 1/2"
per iniettori motori Diesel

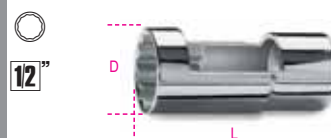

mm	D mm	L mm	
27	36,5	77	3 009600017

960S

chiavi a bussola
con attacco quadro femmina 1/2"
per iniettori motori Diesel

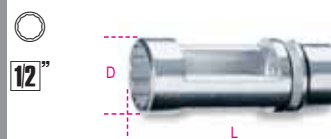

mm	D mm	L mm	
22	31	84	3 009600080

960SN

chiavi per candele
di preriscaldamento motori Diesel



mm	D mm	□	
8	12,0	1/4	2 009600834
9	13,3	1/4	2 009600835
10	14,5	3/8	2 009600836
11	15,8	3/8	2 009600837
12	17,0	3/8	2 009600838

960SL

chiavi a bussola per sonda Lambda
con attacco quadro femmina 1/2"

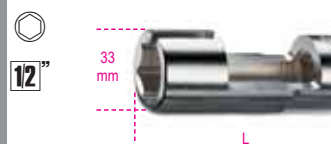

960SL85	○ 22xL= 85 mm	3 009600085
960SL110	○ 22xL= 110 mm	3 009600110

960E

chiave a bussola aperta
per ghiere portainiettori



●1 mm	●2 mm		
32	22	1	009600145

960F

chiave a bussola
per ghiere portainiettori



●1 mm	●2 mm		
32	22	1	009600147

960G

chiave a bussola per ghiere
per autocarri Mercedes-Benz



Ø mm	Ø1 mm		
27	22	3	009600150

960PMC

pompa manuale per taratura
e controllo iniettori Diesel



Bar max.		
400	1	009600200

960AVL

aspiratore di vapori



Bar max.		
6	1	009600210

960I

attrezzo estrazione elettroiniettori Diesel
Common Rail Bosch - Fiat

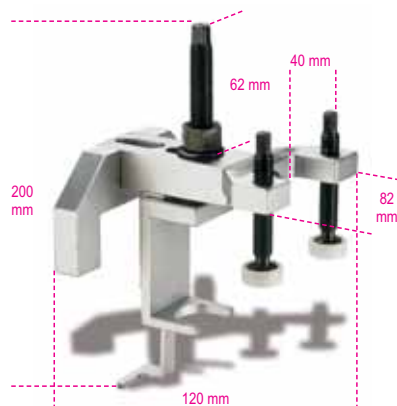

960I		
	1	009600220

960AVE2

attrezzo verifica elettroiniettori
Diesel Common Rail

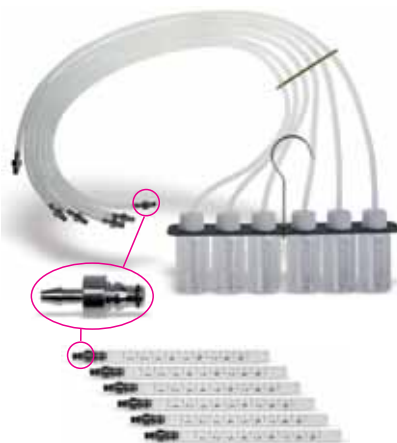

960AVE2		
	1	009600242

960CMB

strumento per controllo
compressione su motori a benzina



Bar		
4+17	1	009600250

440x370x100 mm - 2200 g

960CMD

strumento per controllo
compressione su motori Diesel



Bar		
8+40	1	009600270

440x370x100 mm - 2400 g

960KIT/1

3 finti iniettori e 1 finta candeletta
per 960CMD



960KIT/1		
	1	009600600

240x210x45 mm - 710 g



960P

tester per controllo pressione/depressione con accessori e adattatori



960P 1 009600777

350x320x95 mm - 1,9 kg

960TP

tester pressione digitale con modulo wireless per stampante Beta 1498ST/W



Caratteristiche tecniche:

- bar: 0+80
- Risoluzione: 0,1 bar
- Funzione memorizzazione pressione massima
- Display LCD retroilluminato
- Software in 6 lingue (I, EN, F, ES, PL, NL)
- Funzione correzione pressione ambientale
- Precisione sensore: +/- 1%
- Possibilità di rimuovere e sostituire il sensore

960TP 1 009600300

280x240x77 mm - 800 g

960AD/TP

set di 39 adattatori per 960TP in valigetta di plastica



960AD/TP 1 009600310

450x315x56 mm - 1,5 kg

960CB/TP

set adattatori compressione benzina per 960TP



960CB/TP 1 009600311

960CD/TP

set adattatori compressione diesel per 960TP



960CD/TP 1 009600312

960PBC/TP

set adattatori pressione benzina e bassa pressione common rail per 960TP



960PBC/TP 1 009600313

960PO/TP

set adattatori pressione olio per 960TP



960PO/TP 1 009600314

962

levagomme



L mm	A mm	
300	21	5 009620003
400	25	5 009620004
500	27	3 009620005
600	27	3 009620006

963

leva con estremità a punta e piatta curva



L mm	A mm	
400	23	5 009630001

964

leva con estremità a punta e a becco



L mm	A mm	
400	46	5 009640001

965

leve con estremità piatta curva



L mm	A mm	
300	16	2 009650013
450	20	2 009650014
600	20	2 009650016



965/S3 1 009650019

970

chiave a bussola per serraggio dado mozzo



36 mm 1 009700001

970A

chiave a bussola per serraggio dado mozzo

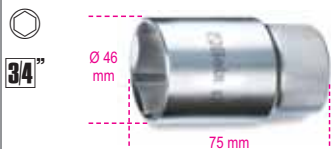

34 mm
35 mm
1 009700003

970B

chiave a bussola per serraggio dadi mozzo Fiat Daily



1 mm
65 mm
1 009700010

978 - 979 - 980

chiavi a croce per dadi ruote

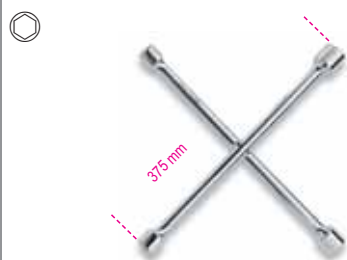

UNI/ISO 6788 DIN 3119

978 2 009780001
17x19x21x22 mm
979 2 009790001
17x19x22x1/2 mm
980 2 009800003
19x22x13/16x1/2 mm

982

chiavi a croce per dadi ruote

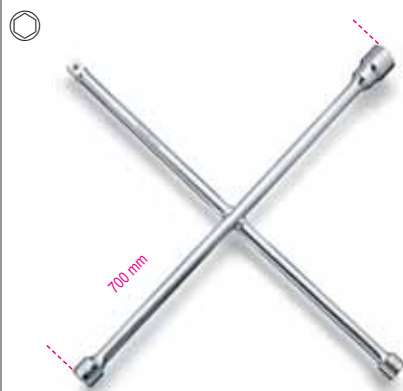

UNI/ISO 6788 DIN 3119

982 2 009820001
24x27x32x3/4 mm

989

pinza combinata per equilibratura ruote



L mm
250 mm
2 009890001

990

pinzetta a molla a punte fini diritte arrotondate, zigrinate in acciaio inossidabile



L mm
130 mm
5 009900001

991

pinzetta a molla a punte fini curve arrotondate, zigrinate in acciaio inossidabile



L mm
130 mm
5 009910001

992

pinzetta a molla con perno a punte fini diritte arrotondate zigrinate, in acciaio inossidabile



L mm
150 mm
5 009920001

993

pinzetta a molla con perno a punte fini curve arrotondate zigrinate, in acciaio inossidabile



L mm
145 mm
5 009930001

993PL

pinzetta a molla a punte fini curve arrotondate, zigrinate in acciaio inossidabile



L mm
150 mm
5 009930010

993G

pinzetta a molla con perno, a punte curve a gomito arrotondate, zigrinate in acciaio inossidabile



L mm
160 mm
5 009930030

993MQ

pinzetta a molla a punte curve arrotondate, zigrinate



EN 60900

L mm
147 mm
2 009930040

994

pinzetta a molla a punte larghe diritte arrotondate, zigrinate in acciaio inossidabile



L mm
150 mm
5 009940001

994PL

pinzetta a molla a punte larghe diritte arrotondate, zigrinate in acciaio inossidabile



L mm
150 mm
5 009940010

994TF

pinzetta a molla, antiacido antimagnetica, a punte larghe diritte arrotondate, zigrinate in acciaio inossidabile



L
mm
150

5 009940020

994MQ

pinzetta a molla a punte diritte arrotondate, zigrinate



EN 60900

L
mm
145

2 009940040

996

pinzetta a molla a becchi diritti a spatola in acciaio inossidabile



L
mm
150

5 009960001

998

pinzetta a molla a becchi larghi diritti incrociati, zigrinati in acciaio inossidabile



L
mm
155

5 009980001

999

pinzetta a molla antiacido antimagnetica, a punte piatte arrotondate in acciaio inossidabile



L
mm
115

5 009990011

999A

pinzette a molla, antiacido antimagnetica, a punte corte finissime in acciaio inossidabile



L
mm
120

5 009990015

999B

pinzetta a molla, antiacido antimagnetica, a punte forti diritte in acciaio inossidabile



L
mm
120

5 009990017

999C

pinzetta a molla, antiacido antimagnetica, a punte finissime diritte in acciaio inossidabile



L
mm
110

5 009990019

999D

pinzetta a molla, antiacido antimagnetica, a punte finissime angolate, in acciaio inossidabile



L
mm
115

5 009990021

999E

pinzetta a molla, antiacido antimagnetica, a punte finissime curve in acciaio inossidabile



L
mm
120

5 009990023

999G

pinzetta a molla, antiacido, antimagnetica con dispositivo di bloccaggio, a punte finissime diritte in acciaio inossidabile



L
mm
140

5 009990027

999/B6

serie di 6 pinzette a molla antiacido ed antimagnetiche



999/B6
999-999A-999B
999C-999D-999E

1 009990050

999T/B

pinzetta a molla, antiacido antimagnetica, a punte piegate arrotondate, in titanio



L
mm
160

2 009990002

1008

pinze a becchi piatti lunghi zigrinati manici ricoperti con 2 strati di PVC antiscivolo



ISO 5745

L	L1	
~	mm	
140	43,0	5 010080004
160	51,5	5 010080006

1008BM

pinze a becchi piatti lunghi zigrinati impugnatura bimatereale



ISO 5745

L	L1	
~	mm	
140	43,0	5 010080034
160	51,5	5 010080036

1009

pinze a becchi mezzotondi lunghissimi zigrinati
manici ricoperti con 2 strati di PVC antiscivolo



L	L1		
~	mm		
140	43,0	2	010090004
160	51,5	2	010090006

1009L/A

pinza a becchi mezzotondi lunghissimi dritti zigrinati, per impieghi speciali
manici ricoperti con 2 strati di PVC antiscivolo



L	L1		
mm	mm		
283	80	2	010090008

1009L/B

pinza a becchi mezzotondi lunghissimi zigrinati piegati a 45°
per impieghi speciali
manici ricoperti con 2 strati di PVC antiscivolo



L	L1		
mm	mm		
273	73	2	010090009

1009L/C

pinza a becchi mezzotondi lunghissimi zigrinati piegati a 90°
per impieghi speciali
manici ricoperti con 2 strati di PVC antiscivolo



L	L1		
mm	mm		
253	45	2	010090010

1010

pinze a becchi tondi lunghi
manici ricoperti con 2 strati di PVC antiscivolo

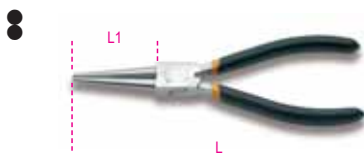

ISO 5745

L	L1		
~	mm		
140	43,0	2	010100004
160	51,5	2	010100006

1010BM

pinze a becchi tondi lunghi
impugnatura bimatériale



ISO 5745

L	L1		
~	mm		
140	43,0	2	010100034
160	51,5	2	010100036

1010MQ

pinze a becchi tondi lunghi



EN 60900

L	L1		
~	mm		
160	51,5	2	010100096

1032

pinze a becchi dritti
per anelli elastici di sicurezza, per fori
manici ricoperti in PVC



UNI 7914 DIN 5256

L	Ø	L		
~	mm	mm		
140	8÷25	142	5	010320013
180	19÷60	182	5	010320017
225	40÷100	227	3	010320021
300	85÷200	302	2	010320028

1033

pinze a becchi piegati a 45°
per anelli elastici di sicurezza, per fori
manici ricoperti in PVC



UNI 7914 DIN 5256

L	Ø	L		
~	mm	mm		
140	8÷25	142	5	010330013
180	19÷60	182	5	010330017
225	40÷100	227	3	010330021

1034

pinze a becchi piegati a 90°
per anelli elastici di sicurezza, per fori
manici ricoperti in PVC



UNI 7914 DIN 5256

L	Ø	L		
~	mm	mm		
130	8÷25	132	5	010340013
170	19÷60	172	5	010340017
210	40÷100	212	3	010340021
290	85÷200	292	2	010340028

1034L

pinza a becchi piegati a 90° lunghi
per anelli elastici di sicurezza, per fori
manici ricoperti in PVC



L	Ø		
mm	mm		
192	40÷100	2	010340320

1036

pinze a becchi dritti
per anelli elastici di sicurezza per alberi
manici ricoperti in PVC



UNI 7915 DIN 5254

L	Ø	L		
~	mm	mm		
140x0,9	3÷10	142	5	010360013
140x1,3	10÷25	142	5	010360014
175	19÷60	177	5	010360017
225	40÷100	227	3	010360021
300	85÷200	302	2	010360028

1037

pinze a becchi piegati a 45°
per anelli elastici di sicurezza per alberi
manici ricoperti in PVC



UNI 7915 DIN 5254

L ~	Ø mm	L mm		
140x0,9	3÷10	142	5	010370013
140x1,3	10÷25	142	5	010370014
175	19÷60	177	5	010370017
225	40÷100	227	3	010370021

1038

pinze a becchi piegati a 90°
per anelli elastici di sicurezza per alberi
manici ricoperti in PVC



UNI 7915 DIN 5254

L ~	Ø mm	L mm		
135x0,9	3÷10	137	5	010380013
135x1,3	10÷25	137	5	010380014
175	19÷60	177	5	010380017
220	40÷100	222	3	010380021
300	85÷200	302	2	010380028

1039

pinza reversibile a becchi diritti
per anelli elastici di sicurezza per fori
e alberi, manici ricoperti in PVC



L ~	Ø mm	Ø mm		
150	10÷15	6÷25	2	010390015

1044

pinza regolabile
cerniera sovrapposta
manici ricoperti in PVC

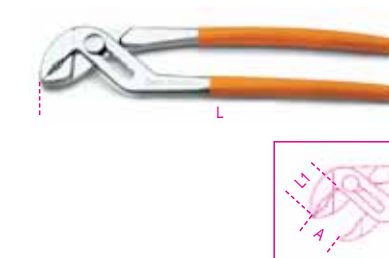

UNI 8608 ISO 8976

L ~	A max mm	L1 mm		
240	33	33	5	010440240

1044F

pinza regolabile, fosfatata
cerniera sovrapposta
manici ricoperti in PVC

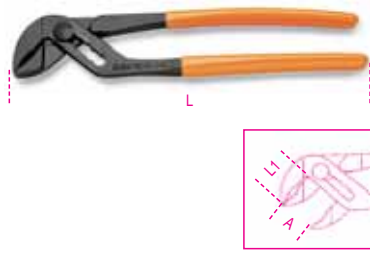

UNI 8608 ISO 8976

L ~	A max mm	L1 mm		
240	33	33	5	010440014

1046

pinza regolabile
cerniera a cremagliera sovrapposta
manici ricoperti in PVC

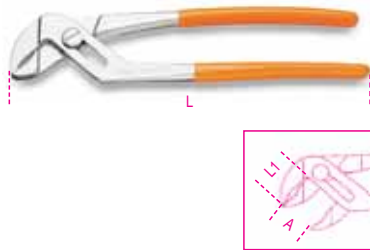

UNI 8608 ISO 8976

L ~	A max mm	L1 mm		
240	28	33	5	010460240
400	107	55	1	010460400

1047

pinza regolabile a pulsante

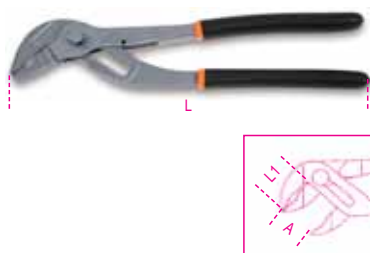

L ~	A max mm	L1 mm		
240	36	35	2	010470240

1048

pinze regolabili
cerniera chiusa
manici ricoperti in PVC

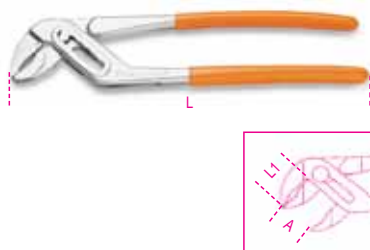

UNI 8608 ISO 8976

L ~	A max mm	L1 mm		
175	30	30	3	010480175
240	34	33	5	010480240
300	46	40	2	010480300

1048V

pinze regolabili
verniciate arancio
cerniera chiusa

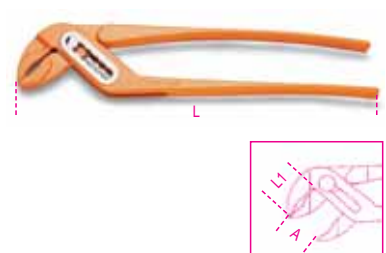

UNI 8608 ISO 8976

L ~	A max mm	L1 mm		
175	30	30	3	010480017
240	34	33	5	010480024
300	46	40	2	010480030

1050

pinza autobloccante
a doppia regolazione

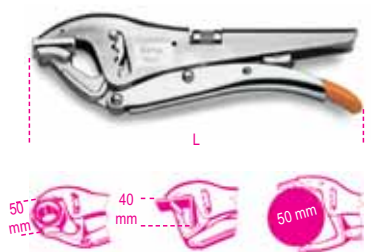

L mm		
220	2	010500022

1051

pinza autobloccante
a doppia regolazione, ganasce lunghe

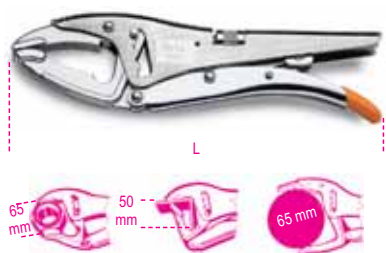

L mm		
255	2	010510025

1051GM

pinza autobloccante
a doppia regolazione, ganaschia oscillante



L mm		
255	2	010510250

1052

pinze regolabili autobloccanti
ganasce concave



L ~ mm	A max mm		
140	22	3	010520014
190	36	3	010520019
240	42	3	010520024
300	55	2	010520030

1053

pinza regolabile autobloccante
ganascia oscillante

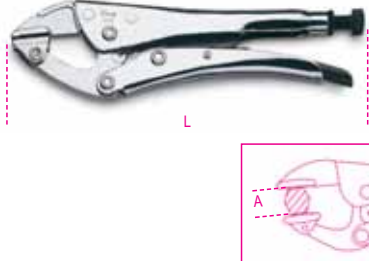

A max mm	L mm		
35	240	2	010530024

1053GM2

pinza regolabile autobloccante
ganasce oscillanti



A max mm	L mm		
47	240	2	010530124

1054

pinza regolabile autobloccante
ganasce diritte

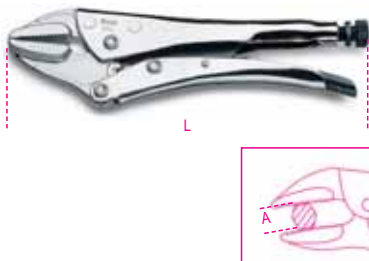

A max mm	L mm		
40	235	2	010540022

1055

pinza regolabile autobloccante
ganasce sagomate

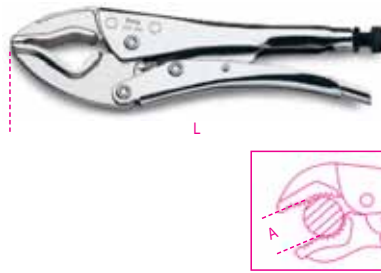

A max mm	L mm		
60	250	2	010550024

1056

pinza regolabile autobloccante
per frigoristi

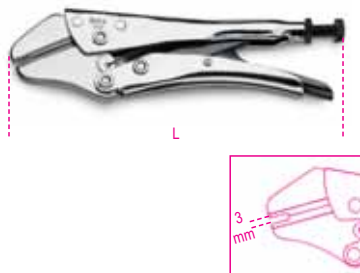

L mm			
190	2	010560019	

1057

pinza automatica autobloccante
con regolazione di forza



L mm			
240	2	010570024	

1058

pinze regolabili autobloccanti
becchi lunghi



L ~ mm	A max mm	S max mm		
180	38	/	2	010580018
240	65	100	2	010580024
310	80	150	2	010580031

1060

pinze regolabili autobloccanti
ganasce a forcella

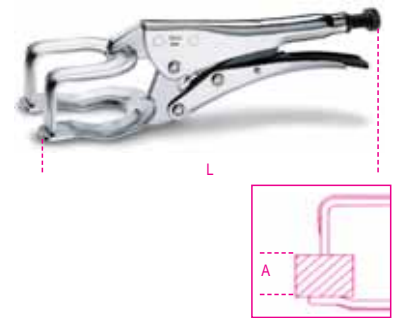

L ~ mm	A max mm		
200	50	2	010600020
280	80	2	010600028

1060AL

pinza regolabile autobloccante
ganasce a forcella
in alluminio



A max mm	L mm		
100	280	2	010600328

1061

pinza regolabile autobloccante
ganasce a forcella

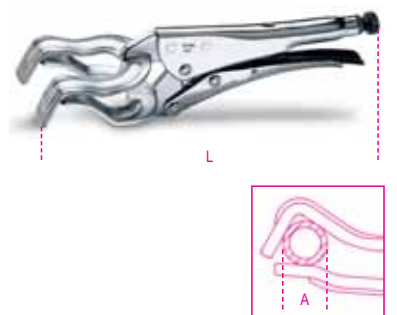

A max mm	L mm		
80	290	2	010610028



1062

pinze regolabili autobloccanti
ganasse a collo di cigno

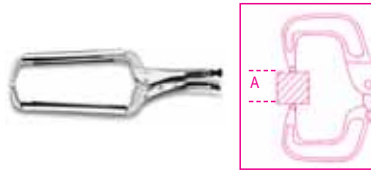

L ~	A max mm		
170	50	2	010620017
290	120	2	010620029
460	250	2	010620046

1062AL

pinze regolabili autobloccanti
ganasse a collo di cigno
in alluminio

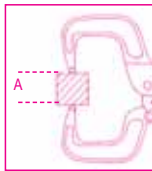

L ~	A max mm		
290	104	2	010620329
350	175	2	010620335

1062GM

pinze regolabili autobloccanti
ganasse a collo di cigno oscillanti



L ~	A max mm		
170	45	2	010620217
290	88	2	010620229
460	260	2	010620246

1063

pinza regolabile autobloccante
per lattonieri



A max mm	L mm		
30	200	2	010630020

1064

pinza regolabile autobloccante
a catena



∅ mm	L mm		
150	240	2	010640024

1065F

pinza foralamiera



L mm			
228		2	010650010

1065P

pinza piegalamiera



L mm			
228		2	010650020

1077

pinza a becchi larghi dritti
per lattonieri
manici ricoperti in PVC



L ~	A mm	L1 mm		
260	60	50	2	010770026

1078

pinza a becchi larghi piegati a 45°
per lattonieri
manici ricoperti in PVC



L ~	A mm	L1 mm		
260	60	45	2	010780026

1080

tronchesi a taglianti diagonali rasi
manici ricoperti con 2 strati
di PVC antiscivolo

Per taglio di materiali plastici



L ~	L1 mm		
140	20	3	010800004
160	22	3	010800006

1081S

tronchesi a taglianti diagonali smerigliati
manici ricoperti in PVC



UNI/ISO 5749

L ~	L1 mm	∅ mm		
140	20	1,6	5	010810014
160	22	1,6	5	010810016

1082

tronchesi a taglianti diagonali
manici ricoperti con 2 strati
di PVC antiscivolo



UNI/ISO 5749

L ~	L1 mm	∅ mm		
140	20	1,6	5	010820004
160	22	1,6	5	010820006

1082BM

tronchesi a taglienti diagonali
impugnatura bimatereale



UNI/ISO 5749

L	L1	≠		
~	mm	mm		
140	20	1,6	3	010820034
160	22	1,6	3	010820036

1082TM

tronchesi a taglienti diagonali
impugnatura trimateriale



UNI/ISO 5749

L	L1	≠		
~	mm	mm		
140	20	1,6	3	010820044
160	22	1,6	3	010820046

1082MQ

tronchesi a taglienti
diagonali



EN 60900

L	L1	≠		
~	mm	mm		
140	20	1,6	3	010820094
160	22	1,6	3	010820096

1084

tronchesi a grande effetto
a taglienti diagonali, manici ricoperti
con 2 strati di PVC antiscivolo



UNI/ISO 5749

L	L1	≠		
~	mm	mm		
140	19	1,4	5	010840004
160	21	1,6	5	010840006
180	25	1,8	3	010840008
200	26	2,0	3	010840010

1084BM

tronchesi a grande effetto
a taglienti diagonali
impugnatura bimatereale



UNI/ISO 5749

L	L1	≠		
~	mm	mm		
140	19	1,4	3	010840034
160	21	1,6	3	010840036
180	25	1,8	3	010840038
200	26	2,0	3	010840040

1084TM

tronchesi a grande effetto
a taglienti diagonali
impugnatura trimateriale



UNI/ISO 5749

L	L1	≠		
~	mm	mm		
160	21	1,6	3	010840046
180	23	1,8	3	010840048
200	26	2,0	2	010840050

1084MQ

tronchesi a grande effetto
a taglienti diagonali



EN 60900

L	L1	≠		
~	mm	mm		
200	26	2,0	2	010840100

1088

tronchesi a grande effetto
a taglienti frontali
manici ricoperti con 2 strati
di PVC antiscivolo



UNI/ISO 5748

L	L1	≠		
~	mm	mm		
140	6	1,4	2	010880004
160	7	1,6	2	010880006
200	8	2,0	2	010880010

1088BM

tronchesi a grande effetto
a taglienti frontali
impugnatura bimatereale



UNI/ISO 5748

L	L1	≠		
~	mm	mm		
140	6	1,4	2	010880034
160	7	1,6	2	010880036
200	8	2,0	2	010880040

1088MQ

tronchesi a taglienti frontali



EN 60900

L	L1	≠		
~	mm	mm		
160	7	1,6	3	010880096

1092V

tronchesi a doppia leva
a taglienti frontali
tipo pesante



UNI/ISO 5748

L	L1	≠		
~	mm	mm		
180	9	2,0	2	010920280
200	10	2,5	2	010920310

1094V

tronchesi a doppia leva
taglienti diagonali
tipo pesante



UNI/ISO 5749

L	L1	≠		
~	mm	mm		
200	23	2,5	2	010940200

1095N

tronchese a doppia leva
a taglienti diagonali



L ~	L1 mm	mm	
195	26	1,6	2 010950010

1096

tenaglie per falegnami



ISO 9243

L ~	L1 mm	
160	21	5 010960016
200	23	5 010960020
250	30	5 010960025

1098

tenaglie per cementisti



ISO 9242 DIN 5242

L ~	L1 mm	
190	12	5 010980190
220	13	5 010980220
250	15	5 010980250
280	18	5 010980280

1098PL

tenaglie per cementisti
manici ricoperti in PVC



ISO 9242 DIN 5242

L ~	L1 mm	
220	13	5 010980320
250	15	5 010980350
280	18	5 010980380

1101

troncabulloni



L mm	L ~	
300	12	2 011010030
350	14	2 011010035
450	18	1 011010045
600	24	1 011010060
750	30	1 011010075
900	36	1 011010090

L mm	R = 80 Kgf=mm ² Ø mm	R = 140 Kgf=mm ² Ø mm	g
300	5	4	745
350	6	5	1043
450	7	6	1537
600	9	7	2540
750	11	8	3870
900	12	9	6170

1101R

lame di ricambio per 1101



mm	1101	
300	300	1 011010130
350	350	1 011010135
450	450	1 011010145
600	600	1 011010160
750	750	1 011010175
900	900	1 011010190

1102

minitroncabulloni

R = \approx 80 Kgf/mm²



L ~	mm	
230	4	3 011020020

1104

tagliafuni per funi in acciaio
impugnature in materiale plastico



L ~	mm	
450	12	1 011040045
800	16	1 011040080

1104R

lame di ricambio per 1104



mm	1104	
450	450	1 011040145
800	800	1 011040180

1105

fustelle in acciaio
brunite



Ø mm	A mm	
2	27	1 011050002
3	27	1 011050003
4	27	1 011050004
5	27	1 011050005
6	27	1 011050006
7	27	1 011050007
8	27	1 011050008
9	27	1 011050009
10	27	1 011050010
12	27	1 011050012
14	27	1 011050014
16	27	1 011050016
18	27	1 011050018
20	27	1 011050020
22	32	1 011050022
24	32	1 011050024
26	32	1 011050026
28	32	1 011050028
30	32	1 011050030
32	37	1 011050032
34	37	1 011050034
36	37	1 011050036
38	37	1 011050038
40	37	1 011050040
42	42	1 011050042
44	42	1 011050044
46	42	1 011050046
48	42	1 011050048
50	42	1 011050050

1105A

battifustella per fustelle 1105
da 3 a 30 mm



L mm	
120	1 011050101

1105B

battifustella per fustelle 1105
da 2 a 50 mm



L
mm
112 1 011050102

1105AD

adattatore per battifustella 1105B



mm
57 1 011050110

1105/C15

assortimento di 15 fustelle
da 3 a 30 mm



1105/C15 1 011050151

1105	3 - 4 - 6 - 8 - 10 - 12 - 14 - 16 18 - 20 - 22 - 24 - 26 - 28 - 30 mm
1105A	

230x190x50 mm - 1100 g

1105/C29

assortimento di 29 fustelle
da 2 a 50 mm



1105/C29 1 011050152

1105	2 - 3 - 4 - 5 - 6 - 7 - 8 - 9 - 10 - 12 14 - 16 - 18 - 20 - 22 - 24 - 26 - 28 30 - 32 - 34 - 36 - 38 - 40 - 42 - 44 46 - 48 - 50 mm
1105B	
1105AD	

325x280x55 mm - 2700 g

1112

cesoie modello americano
lame larghe diritte

R = 60 Kg/mm²



L	L1	S	
mm	mm	mm	
200	50	0,5	2 011120020
250	62	0,8	2 011120025
300	76	1,0	2 011120030
375	105	1,2	1 011120037

1114

cesoie modello americano
lame strette diritte

R = 60 Kg/mm²



L	L1	S	
mm	mm	mm	
200	52	0,5	2 011140020
300	75	1,0	2 011140030

1118

cesoia per taglio reggia

Fe = acciaio comune
Inox = acciaio inossidabile



L	Fe	Inox	
mm	S mm	S mm	
260	1,0	0,8	2 011180026

1120A

cesoia roditrice

Fe = acciaio comune



L	Fe	
mm	S mm	
280	1,2	1 011200101

1120ARL - ARG

ricambi per 1120A



1120ARL	1 011200110
1120ARG	1 011200120

1122

cesoia a doppia leva
lame diritte

Inox = acciaio inossidabile



L	L1	Inox	
mm	mm	S mm	
250	40	1	2 011220020

1123

cesoia a doppia leva destrorsa
lame curve

Inox = acciaio inossidabile



L	L1	Inox	
mm	mm	S mm	
250	40	1	2 011230020

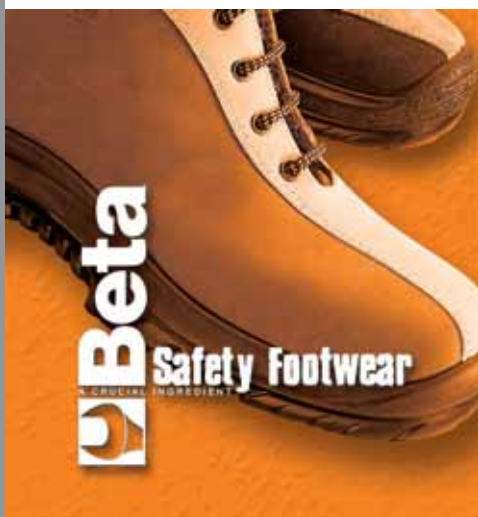

1124

cesoia a doppia leva sinistrorsa
lame curve

Inox = acciaio inossidabile



L mm	L1 mm	Inox S mm	Icona	Icona
250	40	1	2	011240020

1125

cesoia a doppia leva
per tagli dritti e destrorsi

Inox = acciaio inossidabile



L mm	L1 mm	Inox S mm	Icona	Icona
250	35	1	2	011250020

1126

cesoia a doppia leva
per tagli dritti e sinistrorsi

Inox = acciaio inossidabile



L mm	L1 mm	Inox S mm	Icona	Icona
250	35	1	2	011260020

1127

forbici per telefonisti lame diritte



L mm	L1 mm	Icona	Icona
150	35	5	011270001

1128BMX

forbici per elettricisti
lame diritte in acciaio inossidabile
con microdentatura



L mm	L1 mm	Icona	Icona
145	54	5	011280050

1128BM

forbici per elettricisti
lame diritte



L mm	L1 mm	Icona	Icona
145	50	5	011280000

1128P/BM

forbici per elettricisti
modello pesante
lame diritte



L mm	L1 mm	Icona	Icona
145	48	5	011280100

1129BM

forbici per elettricisti
lame curve



L mm	L1 mm	Icona	Icona
145	44	5	011290000

1130BMX

forbici multiuso
lame diritte in acciaio inossidabile
con microdentatura



L mm	L1 mm	Icona	Icona
200	58	1	011300000

1132

tagliacavi
manici ricoperti con 2 strati
di PVC antiscivolo per taglio di cavi isolati
di rame e alluminio



UNI 8791	L mm	mm	Icona	Icona
	170	10	2	011320107
	230	17	2	011320113

1132BM

tagliacavi
impugnature bimatateriale
per cavi isolati in rame e alluminio



UNI 8791	L mm	mm	Icona	Icona
	170	10	2	011320137
	230	17	2	011320143

1132MQ

tagliacavi
per cavi in rame e alluminio



EN 60900	L mm	mm	Icona	Icona
	230	17	2	011320193

1133

tagliacavi
per cavi in rame flessibile
fino a 325 mm²



L mm	mm	Icona	Icona
600	30	1	011330001

1133RL

lame di ricambio per 1133



1133RL	Icona	Icona
	1	011330011

1134

tagliacavi a cricchetto



L mm	mm	Icona	Icona
260	35	1	011340032

1134RL

lama di ricambio per 1134



1134RL 1 011340132

1134A

tagliacavi a cricchetto



L mm 240
mm 45
1 011340045

1134A/RL

lama di ricambio per 1134A



1134A/RL 1 011340145

1136

tagliacavi per cavi di acciaio

Ø 5 mm per cavi con R ≤ 160 Kg/mm²
Ø 4 mm per bulloni in acciaio dolce



L mm 165
2 011360001

1142

pinza spellafili
manici ricoperti con 2 strati
di PVC antiscivolo



UNI 7923
L mm 160
mm² 0,5÷6
5 011420006

1142BM

pinza spellafili
impugnatura bimatériale



UNI 7923
L mm 160
mm² 0,5÷6
3 011420036

1142MQ

pinza spellafili



EN 60900
L mm 160
mm² 0,5÷6
3 011420096

1143

pinza spellafili
con dispositivo di taglio



L mm 165
mm² 0,5÷6
1 011430001

1143R

lama di ricambio per 1143

1143R 1 011430011

1144

spellacavi



L mm 140
mm 6÷20
1 011440014

1144RC

coltello di ricambio per 1144



1144RC 1 011440015

1144D

spellacavi



L mm 170
mm 4,5÷40
1 011440010

1144D/RG

gancio di ricambio per 1144D



1144D/RG 1 011440012

1144D/RL

lama di ricambio per 1144D

1144D/RL 1 011440011

1145

pinza spellafili con dispositivo di taglio
modello automatico



L mm 165
mm² 0,25÷1,5
1 011450018

1145RG

coppia di ganasce di ricambio
per 1145



1145RG 1 011450020

1148A

pinza spellafili autoregolabile
con dispositivo di taglio
#10 mm² (8 AWG) conduttori flessibili
#1,5 mm² (16 AWG) conduttori rigidi



L mm 190
mm² 0,02÷10
34÷8 AWG
1 011480100

1148A/R

lame di ricambio per 1148A



1148A/R 1 011480102

1148B

pinza spellafili autoregolabile con dispositivo di taglio

≠10 mm² (8 AWG) conduttori flessibili
≠1,5 mm² (16 AWG) conduttori rigidi



L mm 190
mm² 4÷16
12÷6 AWG
1 011480200

1148B/R

lame di ricambio per 1148B



1148B/R 1 011480202

1149F

pinza spellafili frontale autoregolabile, con dispositivo di taglio



L mm 175
mm² 0,2 ÷ 6
28÷17 AWG
1 011490010

1150

pinze universali cromate lucide manici ricoperti con 2 strati di PVC antiscivolo



ISO 5746
L ~ L1 mm ≠ mm
160 37 1,6 5 011500006
180 39 1,8 5 011500008
200 43 2,0 5 011500010
220 46 2,0 2 011500012

1150BM

pinze universali cromate lucide impugnatura bimateriale



ISO 5746
L ~ L1 mm ≠ mm
160 37 1,6 3 011500036
180 39 1,8 3 011500038
200 43 2,0 3 011500040
220 46 2,0 2 011500042

1150MQ

pinze universali cromate lucide



EN 60900
L ~ L1 mm ≠ mm
160 37 1,6 3 011500096
180 39 1,8 3 011500098
200 43 2,0 3 011500100
220 46 2,0 2 011500102

1151S

pinze universali smerigliate manici ricoperti in PVC



ISO 5746
L ~ L1 mm ≠ mm
160 37 1,6 5 011510016
180 39 1,8 5 011510018
200 43 2,0 5 011510020
220 46 2,0 3 011510022

1152TM

pinze universali grande potenza cromate lucide impugnatura trimateriale



ISO 5746
L ~ L1 mm ≠ mm
160 37 1,6 3 011520046
180 39 1,8 3 011520048
200 43 2,0 3 011520050

1153

pinze regolabili a due posizioni manici ricoperti in PVC



L ~ L1 mm
160 35 2 011530016
200 43 2 011530020

1162

pinze a becchi piatti lunghissimi diritti zigrinati manici ricoperti con 2 strati di PVC antiscivolo



ISO 5745
L ~ L1 mm ≠ mm
160 56 1,6 5 011620006
200 76 1,6 5 011620010

1162BM

pinze a becchi piatti lunghissimi diritti impugnatura bimateriale



ISO 5745
L ~ L1 mm ≠ mm
160 56 1,6 3 011620036
200 76 1,6 3 011620040

1162MQ

pinze a becchi piatti lunghissimi diritti



EN 60900
L ~ L1 mm ≠ mm
160 56 1,6 3 011620096
200 76 1,6 3 011620100

Beta

1164

pinze a becchi piatti
lungheggissimi piegati zigrinati
manici ricoperti con 2 strati
di PVC antiscivolo



ISO 5745

L	L1	≠		
~	mm	mm		
160	53	1,6	5	011640006
200	70	1,6	5	011640010

1164BM

pinze a becchi piatti
lungheggissimi piegati zigrinati
impugnatura bimatereale



ISO 5745

L	L1	≠		
~	mm	mm		
160	53	1,6	3	011640036
200	70	1,6	3	011640040

1166

pinze a becchi mezzotondi lungheggissimi
diritti zigrinati
manici ricoperti con 2 strati
di PVC antiscivolo



ISO 5745

L	L1	≠		
~	mm	mm		
160	56	1,6	5	011660006
200	76	1,6	5	011660010

1166BM

pinze a becchi mezzotondi lungheggissimi
diritti zigrinati
impugnatura bimatereale



ISO 5745

L	L1	≠		
~	mm	mm		
160	56	1,6	3	011660036
200	76	1,6	3	011660040

1166MQ

pinze a becchi mezzotondi lungheggissimi
diritti



EN 60900

L	L1	≠		
~	mm	mm		
160	56	1,6	3	011660096
200	76	1,6	3	011660100

1168

pinze a becchi mezzotondi lungheggissimi
piegati zigrinati
manici ricoperti con 2 strati
di PVC antiscivolo



ISO 5745

L	L1	≠		
~	mm	mm		
160	50	1,6	5	011680006
200	70	1,6	5	011680010

1168BM

pinze a becchi mezzotondi lungheggissimi
piegati zigrinati
impugnatura bimatereale



ISO 5745

L	L1	≠		
~	mm	mm		
160	50	1,6	3	011680036
200	70	1,6	3	011680040

1168MQ

pinze a becchi mezzotondi lungheggissimi
piegati



EN 60900

L	L1	≠		
~	mm	mm		
160	50	1,6	3	011680096
200	70	1,6	3	011680100

1171BM

pinza per elettronica
a becchi piatti corti lisci
impugnatura bimatereale



ISO 9655

L	L1		
~	mm		
125	18	2	011710101

1172BM

pinza per elettronica
a becchi piatti lunghi lisci
impugnatura bimatereale

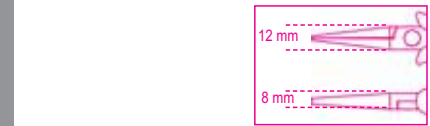

ISO 9655

L	L1		
~	mm		
140	40	2	011720101

1172BM/P

pinza per elettronica
a becchi piatti lunghi piegati lisci
impugnatura bimatereale

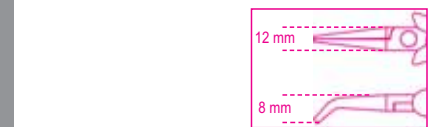

L	L1		
~	mm		
140	38	2	011720102

1173BM

pinza per elettronica
a becchi tondi corti
impugnatura bimatériale

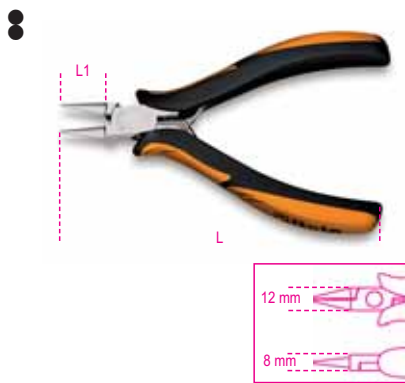

ISO 9655

L	L1		
mm	mm		
125	22	2	011730101

1175BM

pinza per elettronica
a becchi mezzotondi corti lisci
impugnatura bimatériale



ISO 9655

L	L1		
mm	mm		
125	29	2	011750101

1177BM

pinza per elettronica
a becchi mezzotondi lunghi lisci
impugnatura bimatériale

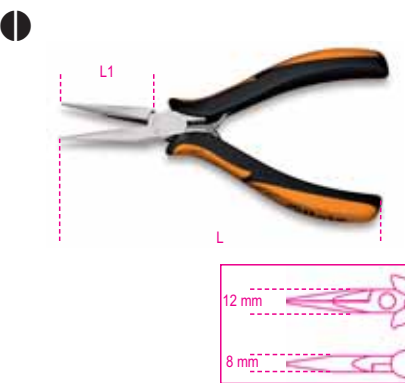

ISO 9655

L	L1		
mm	mm		
140	38	2	011770101

1177BM/Z

pinza per elettronica
a becchi mezzotondi lunghi zigrinati
impugnatura bimatériale



ISO 9655

L	L1		
mm	mm		
140	39	2	011770113

1178BM

pinza per elettronica
a becchi mezzotondi lunghi lisci rastremati
impugnatura bimatériale



ISO 9655

L	L1		
mm	mm		
140	37	2	011780101

1178BM/P

pinza per elettronica
a becchi mezzotondi lunghi lisci rastremati
piegati
impugnatura bimatériale



L	L1		
mm	mm		
140	36,5	2	011780102

1182BM

tronchese per elettronica
a taglienti diagonali semirasi
becchi assottigliati
impugnatura bimatériale



ISO 9654

L	L1	A	Cu		
mm	mm	mm	mm		
120	11	10	1,25	2	011820101

1183BM

tronchese per elettronica
a taglienti diagonali semirasi
becchi arrotondati
impugnatura bimatériale



ISO 9654

L	L1	A	Cu		
mm	mm	mm	mm		
120	11	10	1,25	2	011830101

1184BM

tronchese per elettronica
a taglienti diagonali rasi
becchi arrotondati
impugnatura bimatériale



ISO 9654

L	L1	A	Cu		
mm	mm	mm	mm		
120	11	10	1	2	011840101
130	13	12,5	1,5	2	011840102

1185BM

tronchese per elettronica
a taglienti diagonali rasi
becchi assottigliati
impugnatura bimatériale



ISO 9654

L mm	L1 mm	A mm	Cu mm		
120	11	10	1	2	011850101
130	13	12,5	1,5	2	011850102

1186BM

tronchese per elettronica
a taglienti diagonali rasi
becchi assottigliati scaricati
impugnatura bimatériale



ISO 9654

L mm	L1 mm	A mm	Cu mm		
120	11	10	1	2	011860101
130	13	12,5	1,5	2	011860102

1188BM

tronchese per elettronica
a taglienti diagonali normali
impugnatura bimatériale



ISO 9654

L mm	L1 mm	A mm	S mm		
125	12	12	1,25	2	011880101
130	17	15	2	2	011880102

1190BM

tronchese per elettronica
a taglienti frontali normali
impugnatura bimatériale



ISO 9654

L mm	L1 mm	A mm	Cu mm		
120	12	12	1,25	2	011900113

1191BM

tronchese per elettronica
a taglienti obliqui rasi
becchi lunghi sottili
impugnatura bimatériale



ISO 9654

L mm	L1 mm	A mm	Cu mm		
130	8	12	0,8	2	011910101

1191BM/L

tronchese per elettronica
a taglienti obliqui rasi e spellafilo
impugnatura bimatériale



ISO 9654

L mm	L1 mm	A mm	Cu mm		
130	18	12	1	2	011910110

1200MS

magnetizzatore-smagnetizzatore

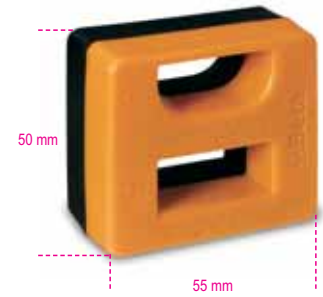

1200MS

5 012000000

1201

giravite per viti
a testa con intaglio



UNI 10562 ISO 2380 DIN 5265

SxAxL mm	L1 mm		
0,4x2,5x50	146	5	012010003
0,4x2,5x75	166	5	012010006
0,5x3x75	171	5	012010009
0,5x3x100	196	5	012010012
0,6x3,5x100	196	5	012010021
0,8x4x100	196	5	012010030
0,8x4x125	221	5	012010033
1,0x5,5x100	209	5	012010039
1,0x5,5x150	259	5	012010042
1,2x6,5x150	270	5	012010051
1,2x8x150	282	3	012010057
1,6x10x200	332	3	012010066



1201/S6
0,5x3x75-0,6x3,5x100
0,8x4x100-1,0x5,5x100
1,2x8x150-1,6x10x200 mm

1 012010206

1201N

giravite per viti a testa con intaglio
tipo cortissimo



UNI 10562 DIN 5265

SxAxL mm	L1 mm		
0,8x4x30	86,5	3	012010103
1,2x6,5x30	86,5	3	012010106

1201DZ

giravite per viti con impronta Dzus®

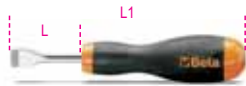

	L mm	L1 mm		
1201DZ	53	173	2	012010501

1202

giravite per viti con impronta a croce Phillips®



Beta EASY



UNI/ISO 8764 DIN 5262

PHxDxL mm	L1 mm		
0x3x60	156	5	012020003
1x4,5x80	189	5	012020009
1x4,5x120	229	5	012020012
2x6x100	220	5	012020018
2x6x150	270	5	012020021
3x8x150	282	3	012020024
4x9,5x200	332	3	012020027



Beta EASY



1202/S4	1	012020204
PH0x3x60-PH1x4,5x120 PH2x6x150-PH3x8x150 mm		

1202N

giravite per viti con impronta a croce Phillips® tipo cortissimo



Beta EASY



UNI/ISO 8764 DIN 5262

PHxDxL mm	L1 mm		
1x4,5x30	86,5	3	012020103
2x6x30	86,5	3	012020106

1203/D

serie giravite

Beta EASY



1203/D5 1 012030001

1201 0,6x3,5x100-1,0x5,5x150
1,2x6,5x150 mm

1202 PH1x4,5x80-PH2x6x100 mm



1203/D7 1 012030007

1201 0,5x3x75-0,8x4x100
1,0x5,5x100-1,2x6,5x150 mm

1202 PH0x3x60-PH1x4,5x80
PH2x6x100 mm



1203/D8 1 012030008

1201 0,5x3x75-0,8x4x125
1,0x5,5x150-1,2x6,5x150 mm

1202 PH0x3x60-PH1x4,5x80
PH2x6x100-PH3x8x150 mm



1203/D10 1 012030010

1201 0,4x2,5x50-0,5x3x75
0,8x4x100-1,0x5,5x100
1,2x6,5x150-1,2x8x150 mm

1202 PH0x3x60-PH1x4,5x80
PH2x6x100-PH3x8x150 mm



1203/D6 1 012030006

1202 PH1x4,5x80-PH2x6x100 mm

1204 0,4x2,5x60-0,5x3x100
0,8x4x100-1,0x5x125 mm



1203/D5PZ 1 012030003

1201 0,5x3x75-0,8x4x125
1,0x5,5x150 mm

1209PZ PZ1x4,5x80-PZ2x6x100 mm

1203/S10

Beta EASY



1203/S10 1 012030021

1201 0,4x2,5x50-0,5x3x75
0,8x4x125-1,0x5,5x150
1,2x6,5x150-1,2x8x150 mm

1202 PH0x3x60-PH1x4,5x80
PH2x6x100-PH3x8x150 mm

1204

giravite per viti senza testa con intaglio



Beta EASY

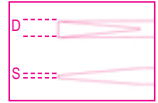
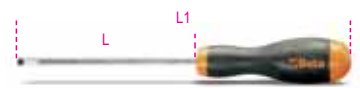

SxDxL mm	L1 mm		
0,4x2,5x60	156	5	012040003
0,5x3x100	196	5	012040009
0,8x4x100	196	5	012040012
1x5x125	234	5	012040018
1,2x6,5x150	270	5	012040024



Beta EASY



1204/S5

0,4x2,5x60-0,5x3x100
0,8x4x100-1x5x125
1,2x6,5x150 mm



1 012040205

1207TX

chiavi maschio con impugnatura per viti con impronta Torx®



Beta EASY



T	L mm	L1 mm		
T6	60	156	5	012070006
T7	60	156	5	012070007
T8	60	156	5	012070008
T9	60	156	5	012070009
T10	80	189	5	012070010
T15	80	189	5	012070015
T20	100	209	5	012070020
T25	100	209	5	012070025
T27	100	220	5	012070027
T30	100	220	5	012070030



Beta EASY



1207TX/D7
T6-T8-T10-T15
T20-T25-T30



1 012070207

1208RTX

chiavi maschio con impugnatura per viti con impronta Tamper Resistant Torx®



	L mm	L1 mm		
T9	60	156	5	012080009
T10	80	189	5	012080010
T15	80	189	5	012080015
T20	100	209	5	012080020
T25	100	209	5	012080025
T27	100	220	5	012080027
T30	100	220	5	012080030



1208RTX/D7 T9-T10-T15-T20 T25-T27-T30	1	012080207
---	---	-----------

1209PZ

giravite per viti con impronta a croce Pozidriv®-Supadriv®



UNI/ISO 8764

PZ	L mm	L1 mm		
0	60	156	5	012090000
1	80	189	5	012090003
2	100	220	5	012090006
3	150	282	3	012090009



1209PZ/S4 PZ0-PZ1-PZ2-PZ3	1	012090204
------------------------------	---	-----------



1227

giravite per viti senza testa con intaglio

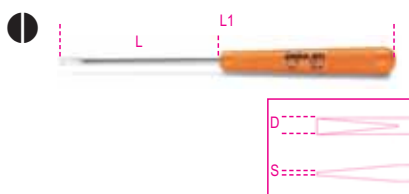

SxDxL mm	L1 mm		
0,5x2,5x60	145	10	012270010
0,6x3x75	160	10	012270020
0,6x3x100	185	10	012270030
0,8x4x100	210	10	012270040
0,8x4x150	260	10	012270050

1228

giravite per viti con impronta a croce Phillips®



PHxDxL mm	L1 mm		
0x3x75	160	10	012280030
1x4,5x100	210	10	012280045

1229LP

microgiravite per viti senza testa con intaglio

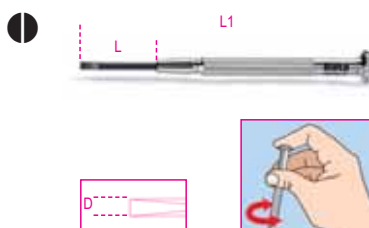

D mm	L mm	L1 mm		
1,0	17	75	5	012290210
1,2	21	85	5	012290212
1,4	21	89	5	012290214
1,8	23	94	5	012290218
2,0	23	98	5	012290220
2,4	26	103	5	012290224
3,0	28	108	5	012290230



1229LP/A6 1,2-1,4-1,8-2-2,4-3 mm	1	012290300
-------------------------------------	---	-----------

1229PH

microgiravite per viti con impronta a croce Phillips®

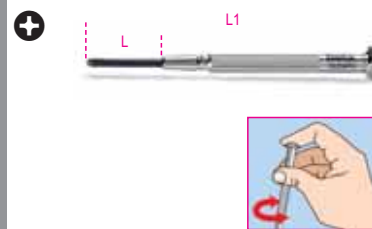

PH	L mm	L1 mm		
0	26	102	5	012290250
1	29	107	5	012290251

1229LPH/A6

serie di 6 microgiravite 1229LP - 1229PH



1229LPH/A6		
1229LP	1,4-1,8-2,4-3	
1229PH	0-1	

1236B

giravite a squadra per viti a testa con intaglio

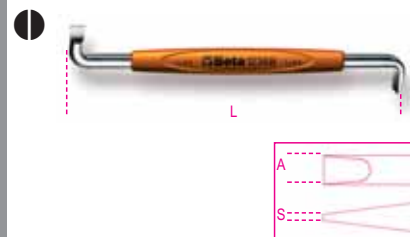

UNI 7079 DIN 5200

SxA mm	L mm		
0,8x4	100	5	012360201
1x5,5	125	5	012360202
1,2x8	150	5	012360204

1238B

giravite a squadra per viti con impronta a croce Phillips®



UNI 7083 DIN 5208

PH	L mm		
1-2	125	5	012380201
3-4	200	5	012380203

1241

giravite a battere per viti a testa con intaglio

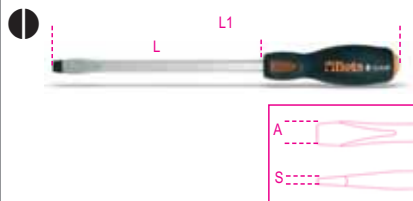

UNI 10562 ISO 2380 DIN 5265

SxAxL mm	L1 mm		
1x5,5x100	202	5	012410039
1,2x6,5x125	240	5	012410050
1,2x8x150	248	3	012410057
1,6x10x200	325	2	012410066

1242

giravite a battere per viti con impronta a croce Phillips®

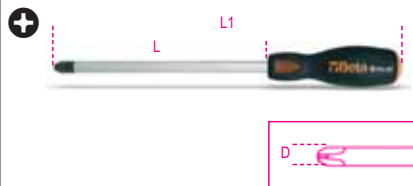

UNI/ISO 8764 DIN 5262

PHxDxL mm	L1 mm		
1x4,5x100	202	5	012420209
2x6x100	215	5	012420218
3x8x150	248	3	012420221
4x11x200	325	2	012420224

1243/D7

serie giravite



1243/D7		1	012430017
1241	1x5,5x100-1,2x6,5x125 1,2x8x150-1,6x10x200 mm		
1242	PH1x4,5x100-PH2x6x100 PH3x8x150 mm		

1249PZ

giravite a battere per viti con impronta a croce Pozidriv®-Supadriv®



UNI/ISO 8764

PZ	L mm	L1 mm		
1	100	202	3	012490003
2	100	215	3	012490006
3	150	248	2	012490009

1250

giravite prensili per viti a testa con intaglio



SxDxL mm	L1 mm		
0,4x2,5x125	155	5	012500025
0,5x3x125	190	5	012500030
0,6x4x125	225	5	012500040
0,7x5x150	255	5	012500050

1251

giravite prensili per viti con impronta a croce Phillips®

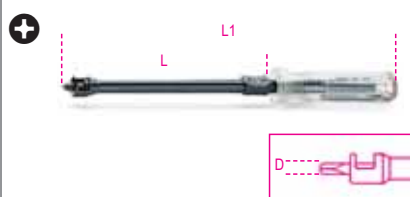

PHxDxL mm	L1 mm		
0x4x125	225	5	012510000
1x5x150	255	5	012510010
2x6x175	280	5	012510020

1252/S5



1252/S5		1	012520001
1250	0,5x3x125-0,6x4x125 0,7x5x150 mm		
1251	PH1x5x150-PH2x6x175 mm		

1255LP

microgiravite per viti senza testa con intaglio

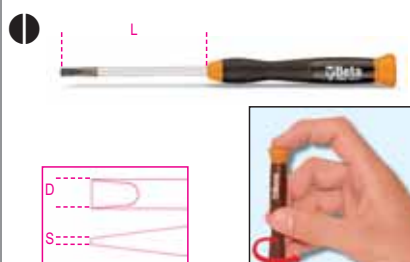

SxD mm	L mm		
0,2x1,2	50	5	012550012
0,25x1,5	50	5	012550015
0,3x1,8	50	5	012550018
0,4x2	75	5	012550020
0,4x2,4	75	5	012550024
0,5x3	75	5	012550030
0,6x3,5	75	5	012550035
0,8x4	75	5	012550040



1255LP/S8
0,2x1,2-0,25x1,5
0,3x1,8-0,4x2-0,4x2,4
0,5x3-0,6x3,5-0,8x4 mm

1 012550100

1255PH

microgiravite per viti con impronta a croce Phillips®



PH	L mm		
00	75	5	012550060
0	75	5	012550063
1	75	5	012550066

1255LPH/S8



1255LPH/S8		1	012550110
1255LP	0,4x2-0,4x2,4-0,5x3 0,6x3,5-0,8x4 mm		
1255PH	PH00-PH0-PH1		

1255ES

microgiravite a chiave maschio esagonale



mm	L mm		
0,9	75	5	012550045
1,3	75	5	012550046
1,5	75	5	012550047
2	75	5	012550048
2,5	75	5	012550049
3	75	5	012550050

1255TX

microgiravite a chiave maschio per viti con impronta Torx®



	L mm		
T5	75	5	012550075
T6	75	5	012550076
T7	75	5	012550077
T8	75	5	012550078
T9	75	5	012550079
T10	75	5	012550080
T15	75	5	012550081
T20	75	5	012550082



1255TX/S8	1	012550120
T5-T6-T7-T8		
T9-T10-T15-T20		

1255BE

microgiravite chiave bussola esagonale



S	L mm		
3,2	75	5	012550085
4	75	5	012550086
5	75	5	012550087
5,5	75	5	012550088

1260

giravite cercafase 150/250V

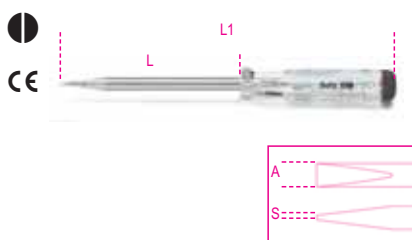

SxAxL mm	L1 mm		
0,5x3,5x100	190	5	012600001

1260A

giravite cercafase 125/250V doppio isolamento



SxAxL mm	L1 mm		
0,5x3x15	150	5	012600010

1262

giravite provacircuito 6÷24V

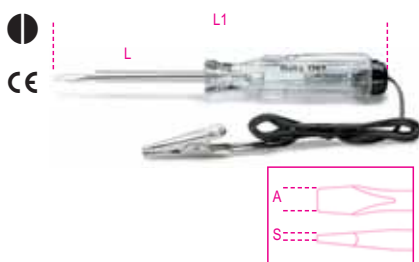

SxAxL mm	L1 mm		
0,5x3x44	123	5	012620001

1270

giravite per viti a testa con intaglio

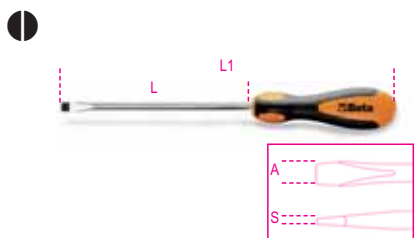

UNI 10562 ISO 2380 DIN 5265

SxAxL mm	L1 mm		
0,4x2,5x50	146	10	012700003
0,4x2,5x75	171	10	012700006
0,5x3x75	171	10	012700009
0,5x3x100	196	10	012700012
0,6x3,5x75	171	10	012700018
0,6x3,5x100	196	10	012700021
0,6x3,5x125	221	10	012700024
0,8x4x75	171	10	012700027
0,8x4x100	196	10	012700030
0,8x4x125	221	10	012700033
0,8x4x150	246	10	012700036
1x5,5x100	208	10	012700039
1x5,5x150	258	10	012700042
1x5,5x200	308	10	012700045
1,2x6,5x100	216	10	012700048
1,2x6,5x150	266	10	012700051
1,2x6,5x200	316	10	012700054
1,2x8x150	277	5	012700057
1,2x8x200	327	5	012700060
1,6x10x150	277	5	012700063
1,6x10x200	327	5	012700066
2x12x250	383	5	012700069



1270/S5

0,5x3x75-0,6x3,5x100
0,8x4x125-1,0x5,5x150
1,2x6,5x150 mm

1 012700201

1270N

giravite per viti a testa con intaglio tipo cortissimo



UNI 10562 DIN 5265

SxAxL mm	L1 mm		
0,8x4x30	86,5	5	012700103
1,2x6,5x30	86,5	5	012700106

1270E

giravite con esagono di manovra per viti a testa con intaglio

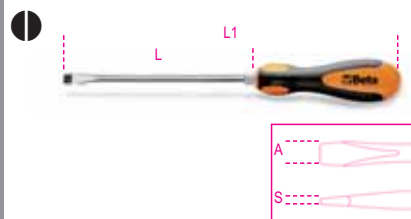

UNI 10562 ISO 2380 DIN 5265

SxAxL mm	L1 mm		
1x5,5x125	233	5	012700153
1,2x6,5x150	266	5	012700156
1,6x10x175	302	5	012700159
2x12x200	333	2	012700162

1272

giravite per viti con impronta a croce Phillips®



UNI/ISO 8764 DIN 5262

PHxDxL mm	L1 mm		
0x3x60	156	10	012720003
0x3x100	196	10	012720006
1x4,5x80	188	10	012720009
1x4,5x120	228	10	012720012
1x4,5x150	258	10	012720015
2x6x100	216	10	012720018
2x6x150	266	10	012720021
2x6x200	316	10	012720023
3x8x150	277	5	012720024
4x10x200	333	5	012720027



1272/S4 1 012720301
 PH0x3x60-PH1x4,5x80
 PH2x6x100-PH3x8x150 mm

1272N

giravite per viti con impronta a croce Phillips® tipo cortissimo



UNI/ISO 8764 DIN 5262

PHxDxL mm	L1 mm	
1x4,5x30	86,5	5 012720103
2x6x30	86,5	5 012720106

1272E

giravite con esagono di manovra per viti con impronta a croce Phillips®

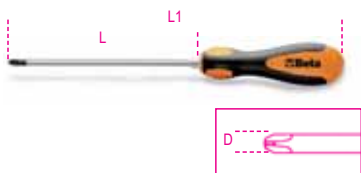

UNI/ISO 8764

PHxDxL mm	L1 mm	
2x6x150	265	5 012720153
3x8x175	302	5 012720156
4x10x200	332	2 012720159

1272L

giravite per viti con impronta a croce Phillips®, tipo lungo

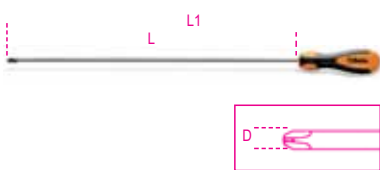

UNI/ISO 8764-1

PHxDxL mm	L1 mm	
0x3x300	395	5 012720203
1x4,5x400	508	5 012720206
2x6x400	515	5 012720209

1272MQ

giravite per viti con impronta a croce Phillips®



EN 60900

PHxDxL mm	L1 mm	
0x3x60	156	3 012720903
1x4,5x80	188	3 012720909
2x6x100	215	3 012720918
3x8x150	283	2 012720924
4x10x200	333	2 012720927



1272MQ/S5 1 012720951
 PH0x3x60-PH1x4,5x80
 PH2x6x100-PH3x8x150
 PH4x10x200 mm

1273MQ/D6

serie di 6 giravite



EN 60900

1273MQ/D6		1 012730951
1274MQ	0,5x3x100 -0,8x4x100 1,0x5,5x125 mm	
1272MQ	PH0x3x60 -PH1x4,5x80 PH2x6x100 mm	

1273/D6...

serie giravite



1273/D6		1 012730001
1270	0,5x3x75-0,8x4x100 1,0x5,5x150 1,2x6,5x150 mm	
1272	PH1x4,5x80-PH2x6x100 mm	



1273/D6E 1 012730002
 1272 PH1x4,5x80-PH2x6x100 mm
 1274 0,6x3x75-0,8x4x100
 1x5x150-1,2x6,5x150 mm



1273/D6PZ 1 012730003
 1270 0,5x3x75-0,8x4x100
 1,0x5,5x150
 1,2x6,5x150 mm
 1279PZ PZ1-PZ2

1273/D8...

serie giravite



1273/D8 1 012730005
 1270 0,5x3x75-0,6x3,5x100
 0,8x4x125-1,0x5,5x150
 1,2x6,5x150 mm
 1272 PH0x3x60 -PH1x4,5x80
 PH2x6x100 mm



1273/D8PZ 1 012730006
 1270 0,5x3x75-0,6x3,5x100
 0,8x4x125-1,0x5,5x150
 1,2x6,5x150 mm
 1279PZ PZ0-PZ1-PZ2



1273/D8H 1 012730007
 1270 1x5,5x150-1,2x8x150 mm
 1272 PH0x3x60 -PH1x4,5x80
 PH2x6x100 mm
 1274 0,5x2,5x60-0,6x3x100-
 0,8x4x100 mm



1273/S...

serie giravite



1273/S7 1 012730004

1272 PH0x3x60 -PH1x4,5x80
PH2x6x100 mm

1274 0,5x2,5x60-0,6x3x100
0,8x4x100-1,0x5x125 mm

1273/S10 1 012730008

1270 0,5x3x75-0,6x3,5x100
0,8x4x125-1,0x5,5x150
1,2x6,5x150 mm

1270N 0,8x4x30 mm

1272 PH0x3x60 -PH1x4,5x80
PH2x6x100 mm

1272N PH1x4,5x30 mm

1273/S11 1 012730009

1270 0,4x2,5x50-0,5x3x75
0,6x3,5x100-0,8x4x125
1,0x5,5x150-1,2x6,5x150
1,6x10x200 mm

1272 PH0x3x60 -PH1x4,5x80
PH2x6x100-PH3x8x150 mm

1274

giravite per viti senza testa
con intaglio

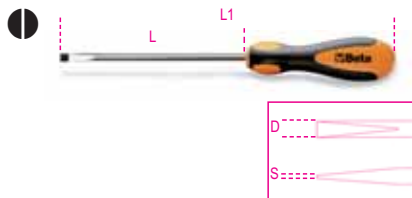

SxDxL mm	L1 mm	
0,5x2,5x60	156	10 012740003
0,6x3x75	171	10 012740006
0,6x3x100	196	10 012740009
0,8x4x100	196	10 012740012
0,8x4x150	246	10 012740015
1x5x125	233	5 012740018
1x5x150	258	5 012740021
1x5x200	308	5 012740022
1,2x6,5x150	277	5 012740024



1274/S5 1 012740301

0,5x2,5x60-0,6x3x75
0,8x4x100-1,0x5x125
1,2x6,5x150 mm

1274L

giravite per viti senza testa
tipo lungo

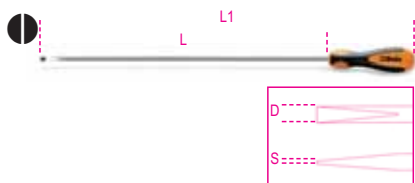

SxDxL mm	L1 mm	
0,5x2,5x200	295	5 012740203
0,6x3x300	395	5 012740206
0,8x4x400	495	5 012740209
1x5x300	407	5 012740212
1x5x400	507	5 012740215
1,2x6,5x400	526	5 012740218

1274MQ

giravite per viti senza testa
con intaglio

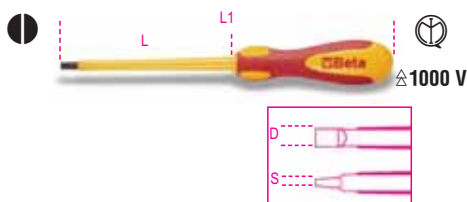

EN 60900

SxDxL mm	L1 mm	
0,4x2,5x75	171	5 012740900
0,5x3x100	196	5 012740903
0,8x4x100	208	5 012740906
1x5,5x125	240	5 012740909
1,2x6,5x150	277	5 012740912
1,2x8x175	307	2 012740915
1,6x10x200	332	2 012740918



1274MQ/S6 1 012740951

0,5x3x100-0,8x4x100
1x5,5x125-1,2x6,5x150
1,2x8x175-1,6x10x200 mm

1277TX

chiavi maschio con impugnatura
per viti con impronta Torx®



	L mm	L1 mm	
T6	50	146	5 012770006
T7	50	146	5 012770007
T8	60	156	5 012770008
T9	60	168	5 012770009
T10	80	188	5 012770010
T15	80	188	5 012770015
T20	100	208	5 012770020
T25	100	216	5 012770025
T27	115	231	5 012770027
T30	115	231	5 012770030
T40	130	257	2 012770040
T45	130	257	2 012770045



1277TX/S6 1 012770201

T10-T15-T20
T25-T27-T30

1277TX/S12 1 012770202

T6-T7-T8-T9-T10
T15-T20-T25-T27
T30-T40-T45



1277TX/D8 1 012770203

T6-T8-T10-T15
T20-T25-T27-T30

1277N/TX

chiavi maschio con impugnatura
per viti con impronta Torx®
tipo cortissimo



	L mm	L1 mm	
T10	30	86,5	5 012770110
T15	30	86,5	5 012770115
T20	30	86,5	5 012770120

1277L/TX

chiavi maschio con impugnatura
per viti con impronta Torx®
tipo lungo



	L mm	L1 mm	
T15	300	395	5 012770315
T20	300	395	5 012770320
T25	300	395	5 012770325
T30	300	395	5 012770330

1278RTX

chiavi maschio con impugnatura
per viti con impronta
Tamper Resistant Torx®

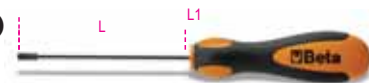

	L mm	L1 mm	
T9	60	168	2 012780009
T10	80	188	2 012780010
T15	80	188	2 012780015
T20	100	208	2 012780020
T25	100	208	2 012780025
T27	115	231	2 012780027
T30	115	231	2 012780030
T40	130	257	2 012780040



1278RTX/S6
T10-T15-T20
T25-T27-T30

1 012780201



1278RTX/D6
T9-T10-T15
T20-T25-T30

1 012780202

1279PZ

giravite per viti con impronta a croce Pozidriv®-Supadriv®



UNI/ISO 8764

PZ	L mm	L1 mm	
0	60	156	5 012790000
1	80	188	5 012790001
2	100	216	5 012790002
2	200	316	5 012790005
3	150	277	2 012790003
4	200	333	2 012790004



1279PZ/S4
PZ 0-1-2-3

1 012790201

1279L/PZ

giravite per viti con impronta a croce Pozidriv®-Supadriv®, tipo lungo



UNI/ISO 8764

PZ	L mm	L1 mm	
0	300	395	5 012790020
1	400	508	5 012790021
2	400	515	5 012790022

1279N/PZ

giravite per viti con impronta a croce Pozidriv®-Supadriv® tipo cortissimo



UNI/ISO 8764

PZ	L mm	L1 mm	
1	30	86,5	5 012790011
2	30	86,5	5 012790012

1279MQ

giravite per viti con impronta a croce Pozidriv®-Supadriv®



EN 60900

PZ	L mm	L1 mm	
0	60	156	3 012790903
1	80	188	3 012790909
2	100	215	3 012790918
3	150	282	3 012790924



1279MQ/S4
PZ 0-1-2-3

1 012790951

1281

impugnatura porta lame giravite



L mm
108

5 012810290

1281PM

portainseri magnetico ad innesto rapido



L mm
165

5 012810292

1281PB

portabussole quadro maschio 1/4"



L mm
175

5 012810293

1281LP

giravite bivalenti per viti a testa con intaglio

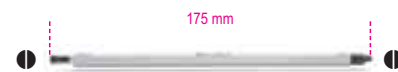

1281LP/1
0,8x4-1,2x6,5 mm

5 012810302

1281LP/2
1x5,5-1,2x6,5 mm

5 012810304

1281PH

giravite bivalenti per viti con impronta a croce Phillips®



PH

1-2

5 012810310

2-3

5 012810312

1281LPH

giravite bivalenti per viti a testa con intaglio e Phillips®



1281LPH/1
PH0-0,8X4 mm

5 012810321

1281LPH/2
PH1-1x5,5 mm

5 012810322

1281LPH/3
PH2-1,2x6,5 mm

5 012810323

1281PZ

giravite bivalenti per viti con impronta a croce Pozidriv®-Supadriv®

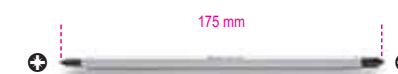

PZ

1-2

5 012810330

2-3

5 012810332

1281PE

chiavi maschio esagonale bivalenti con un'estremità sferica



mm

2,5

5 012810342

3

5 012810343

4

5 012810344

5

5 012810345

6

5 012810346

1281TX

chiavi maschio bivalenti
per viti con impronta Torx®



1281TX/1 T6-T8	5 012810349
1281TX/2 T7-T9	5 012810350
1281TX/3 T10-T15	5 012810351
1281TX/4 T20-T25	5 012810352
1281TX/5 T30-T40	5 012810353

1281RTX

chiavi maschio bivalenti
per viti con impronta Tamper Resistant Torx®



1281RTX/3 T10-T15	5 012810361
1281RTX/4 T20-T25	5 012810362
1281RTX/5 T30-T40	5 012810363

1281/A9

assortimento di 9 giravite bivalenti
e 1 accessorio in astuccio



1281/A9 1 012810609

1281	
1281LPH/1	PH0-0,8x4 mm
1281LPH/2	PH1-1x5,5 mm
1281LPH/3	PH2-1,2x6,5 mm
1281PZ/1	PZ1-PZ2
1281PE	2,5 mm
1281PE	3 mm
1281PE	4 mm
1281PE	5 mm
1281PE	6 mm

1281TX/A8

assortimento di 8 giravite bivalenti
e 1 accessorio in astuccio



1281TX/A8 1 012810619

1281	
1281LPH/1	PH0-0,8x4 mm
1281LPH/2	PH1-1x5,5 mm
1281LPH/3	PH2-1,2x6,5 mm
1281TX/1	T6-T8
1281TX/2	T7-T9
1281TX/3	T10-T15
1281TX/4	T20-T25
1281TX/5	T30-T40

1281/B28A

assortimento di 16 giravite bivalenti, 9 chiavi
a bussola 1/4", 2 accessori e 1 impugnatura di
manovra, in busta



1281/B28A 1 012810500

900	4 - 4,5 - 5 - 5,5 6 - 7 - 8 - 9 - 10 mm
1281	®
1281PB	■ 1/4
900/25	
1281LP/1	0,8x4 - 1,2x6,5 mm
1281LP/2	1,0x5,5 - 1,2x6,5 mm
1281PH/1	PH1 - PH2
1281PH/2	PH2 - PH3
1281PZ/1	PZ1 - PZ2
1281PZ/2	PZ2 - PZ3
1281PE	2,5 - 3 - 4 - 5 - 6 mm
1281TX/1	T6 - T8
1281TX/2	T7 - T9
1281RTX/3	T10 - T15
1281RTX/4	T20 - T25
1281RTX/5	T30 - T40

1281/BV 1 012810501

1290

giravite per viti a testa con intaglio

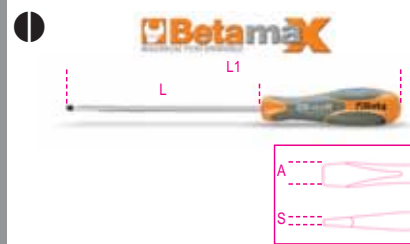

UNI 10562 ISO 2380 DIN 5265

SxAxL mm	L1 mm	
0,4x2,5x50	146	5 012900003
0,4x2,5x75	171	5 012900006
0,5x3x75	171	10 012900009
0,5x3x100	196	10 012900012
0,5x3x125	221	10 012900015
0,6x3,5x75	171	10 012900018
0,6x3,5x100	196	10 012900021
0,6x3,5x125	221	10 012900024
0,8x4x75	171	10 012900027
0,8x4x100	196	10 012900030
0,8x4x125	221	10 012900033
0,8x4x150	246	10 012900036
1x5,5x100	209	10 012900039
1x5,5x150	259	10 012900042
1x5,5x200	309	5 012900045
1,2x6,5x100	220	10 012900048
1,2x6,5x150	270	10 012900051
1,2x6,5x200	320	5 012900054
1,2x8x150	282	3 012900057
1,2x8x200	332	3 012900060
1,6x10x150	282	3 012900063
1,6x10x200	332	3 012900066
2x12x250	382	2 012900069

1290/S...

serie giravite



1290/S5 1 012900305

1290 0,5x3x75-0,8x4x100 -1x5,5x150
1,2x6,5x150 -1,2x8x150 mm

1290/S9 1 012900309

1290 0,4x2,5x75 -0,5x3x125
0,8x4x125-1x5,5x150
1,2x6,5x150 -1,2x8x200
1,6x10x200 mm

1290N 0,8x4x30 -1,2x6,5x30 mm

Beta

1290N

giravite per viti a testa con intaglio tipo cortissimo



UNI 10562 DIN 5265

SxAxL mm	L1 mm		
0,8x4x30	86,1	5	012900103
1,2x6,5x30	86,1	5	012900106

1290E

giravite con esagono di manovra per viti a testa con intaglio



UNI 10562 ISO 2380 DIN 5265

SxAxL mm	L1 mm		
1x5,5x125	234	3	012900153
1,2x6,5x150	270	3	012900156
1,6x10x175	307	2	012900159
2x12x200	332	2	012900162

1292

giravite per viti con impronta a croce Phillips®



UNI/ISO 8764 DIN 5262

PHxDxL mm	L1 mm		
0x3x60	156	10	012920003
0x3x100	196	5	012920006
1x4,5x80	189	10	012920009
1x4,5x120	229	10	012920012
1x4,5x150	259	5	012920015
2x6x100	220	10	012920018
2x6x150	270	10	012920021
2x6x200	320	5	012920023
3x8x150	282	3	012920024
4x10x200	332	3	012920027



1292/S4	1	012920304
PH0x3x60-PH1x4,5x80		
PH2x6x100-PH3x8x150 mm		

1292N

giravite per viti con impronta a croce Phillips® tipo cortissimo



UNI/ISO 8764 DIN 5262

PHxDxL mm	L1 mm		
1x4,5x30	86,1	5	012920103
2x6x30	86,1	5	012920106

1292E

giravite con esagono di manovra per viti con impronta a croce Phillips®



UNI/ISO 8764

PHxDxL mm	L1 mm		
2x6x150	270	3	012920153
3x8x175	307	2	012920156
4x10x200	332	2	012920159



1292L

giravite per viti con impronta a croce Phillips®, tipo lungo



UNI/ISO 8764-1

PHxDxL mm	L1 mm		
0x3x300	396	3	012920203
1x4,5x400	509	3	012920206
2x6x400	520	3	012920209

1293/D...

serie giravite



1293/D6	1	012930401
---------	---	-----------

1290 0,6x3,5x75-1x5,5x150
1,2x6,5x150 mm

1292 PH0x3x60 -PH1x4,5x80
PH2x6x100 mm

1293/D8	1	012930403
---------	---	-----------

1290 0,5x3x75-0,8x4x100
1x5,5x150-1,2x6,5x150
1,2x8x150 mm

1292 PH0x3x60 -PH1x4,5x80
PH2x6x100 mm

1293/D11	1	012930405
----------	---	-----------

1290 0,4x2,5x75 -0,6x3,5x100
0,8x4x125-1x5,5x100-
1,2x6,5x100
1,2x8x150-1,6x10x150 mm

1292 PH0x3x60 -PH1x4,5x120
PH2x6x150-PH3x8x150 mm

1293/D8H	1	012930411
----------	---	-----------

1290 1x5,5x100-1,2x6,5x150 mm

1292 PH0x3x60 -PH1x4,5x80
PH2x6x100 mm

1294 0,5x2,5x60-0,6x3x75
0,8x4x100 mm

1293/D7	1	012930407
---------	---	-----------

1290 0,5x3x100-0,8x4x125
1x5,5x150-1,2x6,5x150 mm

1299PZ PZ0x3x60-PZ1x4,5x80
PZ2x6x100 mm

1293/S...

serie giravite



1293/S10 1 012930201

1290 0,4x2,5x50 -0,6x3,5x100
1x5,5x100-1,2x6,5x150
1,2x8x150-1,6x10x200 mm
1292 PH0x3x60 -PH1x4,5x80
PH2x6x100-PH3x8x150 mm

1293/S12 1 012930203

1290 0,5x3x75-0,8x4x125
1x5,5x150-1,2x6,5x150
1,2x8x200 mm
1290N 0,8x4x30 mm
1292 PH0x3x60 -PH1x4,5x80
PH2x6x100-PH3x8x150 mm
1292N PH1x4,5x30-PH2x6x30 mm

1293E/S5 1 012930211

1290E 1x5,5x125-1,2x6,5x150
1,6x10x175 mm
1292E PH2x6x150-PH3x8x175 mm

1293/S7 1 012930207

1292 PH0x3x60 -PH1x4,5x80
PH2x6x100 mm
1294 0,5x2,5x60-0,6x3x75
0,8x4x100-1x5x125 mm

1293/S8H 1 012930209

1290 1,2x6,5x150-1,2x8x150 mm
1292 PH0x3x60 -PH1x4,5x80
PH2x6x100 mm
1294 0,5x2,5x60-0,6x3x100
0,8x4x100 mm

1293/S8PZ 1 012930205

1290 0,4x2,5x75 -0,6x3,5x75
1x5,5x100-1,2x6,5x150 mm
1299PZ PZ0x3x60-PZ1x4,5x80
PZ2x6x100-PZ3x8x150 mm

1293ES

chiavi maschio esagonale
con impugnatura



mm	L mm	L1 mm	
2	100	196	5 012930001
2,5	100	196	5 012930002
3	100	196	5 012930003
4	100	196	5 012930004
5	100	209	5 012930005
6	125	245	5 012930006
8	150	282	2 012930008



1293ES/S7 1 012930057
2-2,5-3-4-5-6-8 mm

1293BP

chiavi maschio esagonale
ad estremità sferica con impugnatura



mm	L mm	L1 mm	
2	100	196	5 012930501
2,5	100	196	5 012930502
3	125	221	5 012930503
4	125	221	5 012930506
5	125	229	5 012930509
6	140	260	5 012930512
8	160	292	2 012930515



1293BP/S7 1 012930558
2-2,5-3-4-5-6-8 mm

1294

giravite per viti senza testa
con intaglio



SxDxL mm	L1 mm	
0,5x2,5x60	156	5 012940003
0,6x3x75	171	5 012940006
0,6x3x100	196	5 012940009
0,8x4x100	196	5 012940012
0,8x4x150	246	5 012940015
1x5x125	234	5 012940018
1x5x150	259	5 012940021
1x5x200	309	5 012940024
1,2x6,5x150	282	5 012940027
1,6x8x150	282	3 012940030



1294/S5 1 012940305
0,5x2,5x60-0,6x3x100
0,8x4x100-1x5x125
1,2x6,5x150 mm

1294L

giravite per viti senza testa con intaglio
tipo lungo

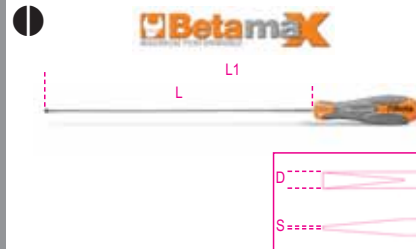

SxDxL mm	L1 mm	
0,5x2,5x200	296	3 012940203
0,6x3x300	396	3 012940206
0,8x4x400	496	3 012940209
1x5x300	409	3 012940212
1x5x400	509	3 012940215
1,2x6,5x400	532	3 012940218

1295

giravite a percussione



L mm 130 1 012950001

1295/C14

giravite a percussione
con 14 inserti e bussola portainseri



1295/C14 1 012950108

	866LP	1,2x6,5 - 1,6x10 mm
	866PH	PH2 - PH3
	866PZ	PZ2 - PZ3
	866PE	5 - 6 mm
	866TX	T27 - T30 - T40 - T45 - T50 - T55
	895/6	□ 1/2 - ○ 5/16
	1295	■ 1/2

170x100x35 mm - 1300 g

1296/90

giravite portainseri angolare
inclinato a 90°



ISO 1173 E 6,3

1296/90

○ 1/4 - ● 1/4

capacità max 30Nm

1 012960001

1296/C19

1 giravite portainseri angolare
inclinato a 90°, 1 impugnatura di manovra,
18 inserti per avvitatori e 1 portainseri



1296/C19

1 012960101

	1296/90	○ 1/4 - ● 1/4
	861LP	0,5x3 - 0,6x4,5 - 0,8x5,5 - 1,2x6,5 mm
	861PE	2 - 3 - 4 - 5 mm
	861PH	PH0 - PH1 - PH2 - PH3
	861RTX	T9 - T10 - T15 - T20 - T25 - T27
	850BM/C	○ 1/4"
	882M1	○ 1/4 - ● 1/4

270x120x45 mm - 980 g

1297TX

chiavi maschio con impugnatura
per viti con impronta Torx®



	L mm	L1 mm	
T6	50	146	5 012970006
T7	50	146	5 012970007
T8	60	156	5 012970008
T9	60	169	5 012970009
T10	80	189	5 012970010
T15	80	189	5 012970015
T20	100	209	5 012970020
T25	100	209	5 012970025
T27	115	235	5 012970027
T30	115	235	5 012970030
T40	130	262	2 012970040
T45	130	262	2 012970045



Betamax



1297TX/S12
T6-T7-T8-T9-T10
T15-T20-T25-T27
T30-T40-T45

1 012970312



Betamax



1297TX/D6
T10-T15-T20
T25-T27-T30

1 012970409

1298RTX

chiavi maschio con impugnatura
per viti con impronta
Tamper Resistant Torx®



Betamax



	L mm	L1 mm	
T9	60	169	5 012980009
T10	80	189	5 012980010
T15	80	189	5 012980015
T20	100	209	5 012980020
T25	100	209	5 012980025
T27	115	235	5 012980027
T30	115	235	5 012980030
T40	130	262	2 012980040



Betamax



1298RTX/S8
T9-T10-T15-T20
T25-T27-T30-T40

1 012980308

1299PZ

giravite per viti con impronta
a croce Pozidriv®-Supadriv®



UNI/ISO 8764

PZ	L mm	L1 mm	
0	60	156	5 012990000
1	80	189	5 012990003
2	100	220	5 012990006
3	150	282	2 012990009
4	200	332	2 012990012



Betamax



1299PZ/S6
1299PZ PZ0-PZ1-PZ2-PZ3
1299N/PZ PZ1-PZ2

1 012990306

1299N/PZ

giravite per viti con impronta
a croce Pozidriv®-Supadriv®
tipo cortissimo



UNI/ISO 8764

PZ	L mm	L1 mm	
1	30	86,1	5 012990021
2	30	86,1	5 012990024

1302

tasso con impugnatura testa tonda
convessa e a penna



1 013020001

1303

tasso a virgola



1 013030001

1304

tasso a suola

g
875

1 013040001

1308

tasso ovoidale

g
1100

1 013080001

1314tasso a teste tonde
convessa e pianag
760

1 013140001

1305

tasso curvo

g
1190

1 013050001

1309

tasso a doppia penna

g
460

1 013090001

1326

leva a cazzuola

g
560

1 013260001

1305Z

tasso curvo zigrinato

g
1065

1 013050002

1310

tasso a rotaia

g
1225

1 013100001

1327leva a cucchiaio
pesanteg
1075

1 013270001

1306

tasso a tacco bombato

g
1040

1 013060001

1312

tasso a incudine

g
1220

1 013120001

1329

leva curva e piana

g
1800

1 013290001

1307

tasso rettangolare bombato

g
1100

1 013070001

1313

tasso a tampone

g
990

1 013130001

1330

leva a gomito e piana



g			
2125		1	013300001

1331

leva a gola con linguetta in cuoio



g			
1100		1	013310001

1335BM

battilamiera con impugnatura in materiale plastico



g			
500		5	013350010

1338A - 1338B

portalima con lima a dentatura radiale, piatta flessibile



	1"		
1338A	9	2	013380001
1338B	12	2	013380002

1338

portalima per 1338R



1338		2	013380003
------	--	---	-----------

1338R9 - 1338R12

lime di ricambio per 1338A e 1338B



	1"		
1338R9	9	2	013380004
1338R12	12	2	013380005

1342

scalpello extrapiatto con tagliente diritto



L			
mm		5	013420001
235			

1342PM

scalpello extrapiatto con tagliente diritto con paramano

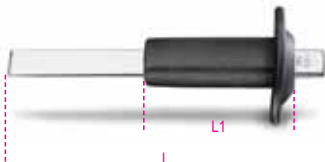

L	L1		
mm	mm	2	013420002
235	118		

1342PMR

paramano di ricambio per 1342



1342PMR		1	013420003
---------	--	---	-----------

1343

scalpello piatto con tagliente laterale



L			
mm		5	013430001
200			

1345martello con testa tonda convessa e penna
manico in legno

1345		3	013450000
------	--	---	-----------

1345Pmartello con testa tonda piana e penna
manico in legno

1345P		3	013450001
-------	--	---	-----------

1351martello con testa tonda piana e penna sferica
manico in legno

1351		3	013510000
------	--	---	-----------

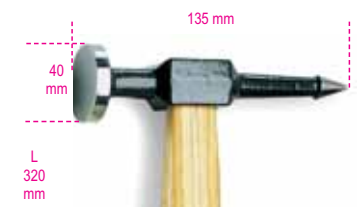
1353martello con testa tonda piana e penna a punta
manico in legno

1353		3	013530000
------	--	---	-----------

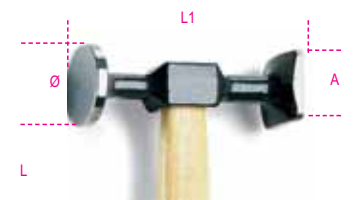
1357/32 - 1357/40martelli con teste piane
tonda e quadra
manico in legno

1357/32		3	013570032
---------	--	---	-----------

Ø = 32 mm
A = 25 mm
L1 = 100 mm
L = 280 mm

1357/40		3	013570040
---------	--	---	-----------

Ø = 40 mm
A = 35 mm
L1 = 105 mm
L = 290 mm



1357Z/32 - 1357Z/40

martelli con teste piane
tonda zigrinata e quadra liscia
manico in legno



1357Z/32 3 013570132

Ø = 32 mm
A = 25 mm
L1 = 100 mm
L = 280 mm

1357Z/40 3 013570140

Ø = 40 mm
A = 35 mm
L1 = 105 mm
L = 290 mm

1359T

martello con testa tonda piana
e penna orizzontale
manico in legno



1359T 3 013590001

1369/C11X

assortimento di 11 utensili



1369/C11X 1 013690023

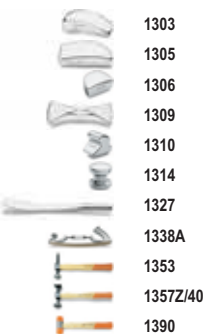

470x340x70 mm - 15,2 kg

1369A/8

assortimento di 8 utensili
per cristalli auto



1369A/8 1 013690011

1370

martelli tipo tedesco
per meccanici
manico in legno



UNI 7778 DIN 1041

g	L1 mm	L mm	
100	82	260	5 013700051
200	95	280	5 013700052
300	105	300	5 013700053
400	112	310	5 013700054
500	118	320	5 013700055
600	122	330	5 013700056
800	130	350	4 013700058
1000	135	360	4 013700060
1500	145	380	2 013700065
2000	155	400	1 013700070

1370/MR...

manici di ricambio per 1370



1370/MR100 1370/100	4 013700081
1370/MR200 1370/200	4 013700082
1370/MR300 1370/300	4 013700083

1370/MR400 1370/400	4 013700084
1370/MR500 1370/500	4 013700085
1370/MR600 1370/600	4 013700086
1370/MR800 1370/800	4 013700088
1370/MR1000 1370/1000	4 013700090
1370/MR1500 1370/1500	4 013700095
1370/MR2000 1370/2000	4 013700100

1370T

martelli tipo tedesco
per meccanici
manico in fibra



g	L1 mm	L mm	
200	95	280	5 013700620
300	105	300	5 013700630
500	118	320	5 013700650
800	130	350	4 013700680
1000	135	360	4 013700700
1500	145	365	2 013700750

1370F

martelli tipo francese
per meccanici
manico in legno



NFE 71.014

A mm	L1 mm	L mm	
24	77	260	2 013700424
26	80	260	2 013700426
28	86	280	2 013700428
30	92	280	2 013700430
32	100	300	2 013700432
36	104	300	2 013700436
40	110	330	2 013700440
42	116	330	2 013700442
50	138	380	2 013700450
60	160	380	2 013700460

1370F/MR...

manici di ricambio per 1370F



1370F/MR24 1370F/24-26	2 013700474
1370F/MR28 1370F/28-30	2 013700478
1370F/MR32 1370F/32-36	2 013700482
1370F/MR40 1370F/40-42	2 013700490
1370F/MR50 1370F/50	2 013700495
1370F/MR60 1370F/60	2 013700496

1370FT

martelli tipo francese per meccanici,
manico in fibra



A mm	L1 mm	L mm		
28	86	280	1	013700528
30	92	280	1	013700530
32	100	300	1	013700532
36	104	300	1	013700536
40	110	330	1	013700540
42	116	330	1	013700542
50	138	380	1	013700550
60	160	380	1	013700560

1374F

martelli tipo francese
per falegnami
manico in legno



HICKORY

NF E 71.012

A mm	L1 mm	L mm		
16	80	250	2	013740416
20	86	270	2	013740420
22	92	290	2	013740422
26	103	290	2	013740426
28	108	310	2	013740428
30	117	310	2	013740430

1374F/MR...

manici di ricambio per 1374F



1374F/MR16	2	013740456
1374F/16		
1374F/MR20	2	013740460
1374F/20		
1374F/MR22	2	013740462
1374F/22-26		
1374F/MR28	2	013740468
1374F/28		
1374F/MR30	2	013740470
1374F/30		

1375

martello con penna
a granchio
manico in legno



g	L1 mm	L mm		
300	95	300	3	013750000

1375/MR

manici di ricambio per 1375



1375/MR	2	013750003
---------	---	-----------

1375A

martelli con penna
a granchio
manico in materiale plastico



oz	g		
16	450	3	013750016
20	570	3	013750020

1375B

martelli con penna
a granchio
manico in acciaio



oz	g		
16	450	3	013750026
20	570	3	013750030

1376X

martelli a testa quadra,
con sede portachiodo e calamita,
penna a granchio, per carpentieri
manico in legno



g	L1 mm	L mm		
250	125	450	3	013760125
300	130	450	3	013760130
400	132	450	3	013760140

1376X/MR

manico di ricambio
per 1376X



1376X/MR	2	013760161
----------	---	-----------

1376XT

martelli a testa quadra,
con sede portachiodo e calamita,
penna a granchio, per carpentieri
manico in materiale plastico



g	L1 mm	L mm		
250	125	500	3	013760525
300	130	500	3	013760530
400	132	500	3	013760540

1376XT/MR

manico di ricambio
per 1376XT



1376XT/MR	2	013760585
-----------	---	-----------

1376A

martelli da muratore a penna larga
e testa quadra
manico in legno



g	L1 mm	L mm		
300	170	400	3	013760203
400	175	400	3	013760204
500	195	400	3	013760205

1376B

martellina da muratore
con penna a punta e testa quadra
manico in legno



g	L1 mm	L mm		
300	220	400	3	013760303



1377

martelli con testa tonda e penna sferica per calderai e lattonieri manico in legno



HICKORY

g	L1 mm	L mm	
340	95	330	2 013770134
570	110	350	2 013770157
900	120	380	2 013770190

1377/MR...

manici di ricambio per 1377



1377/MR340	2 013770234
1377/340	
1377/MR570	2 013770257
1377/570	
1377/MR900	2 013770290
1377/900	

1378

martelli con testa tonda e penna simmetrica per calderai e lattonieri manico in legno



HICKORY

g	L1 mm	L mm	
340	100	330	2 013780134
570	115	350	2 013780157

1378/MR...

manici di ricambio per 1378



1378/MR340	2 013780234
1378/340	
1378/MR570	2 013780257
1378/570	

1379F

martelli tipo francese per elettricisti manico in legno



HICKORY

NF E 71.011

A mm	L1 mm	L mm	
16	126	250	2 013790416
18	135	250	2 013790418
20	142	260	2 013790420

1379F/MR...

manici di ricambio per 1379F



1379F/MR16	2 013790426
1379F/16-18	
1379F/MR20	2 013790430
1379F/20	

1380

mazzette manico in legno



HICKORY

UNI 7777 DIN 6475

g	L1 mm	L mm	
800	90	260	2 013800208
1000	95	260	2 013800210
1250	100	260	2 013800212
1500	110	280	2 013800215
2000	120	300	2 013800220

1380/MR...

manici di ricambio per 1380



1380/MR800	2 013800238
1380/800-1000-1250	
1380/MR1500	2 013800245
1380/1500	
1380/MR2000	2 013800250
1380/2000	

1380S

mazzette con collare salvamanico manico in legno collare in materiale plastico



g	L1 mm	L mm	
800	90	260	2 013800400
1000	95	260	2 013800405
1250	100	260	2 013800410
1500	110	260	2 013800415

1380S/MR...

manici di ricambio per 1380S



1380S/MR800	2 013800417
1380S/800-1000-1250	
1380S/MR1500	2 013800419
1380S/1500	

1380T

mazzette manico in fibra



g	L1 mm	L mm	
800	85	260	2 013800308
1000	100	260	2 013800310
1250	110	260	2 013800312
1500	120	260	2 013800315

1381

mazze a coppia manico in legno hickory



g	L1 mm	L mm	
3000	142	800	1 013810030
4000	152	900	1 013810040
5000	162	900	1 013810050
8000*	185	900	1 013810080

* = manico in frassino

1381/MR...

manici di ricambio per 1381



	g	L1 mm	L mm	
1381/MR3-4	2	013810730		
1381/3000-4000				
1381/MR5	2	013810750		
1381/5000				
1381/MR8	2	013810780		
1381/8000				

1385N

mazzuole
con testa in rame
manico in legno



g	L1 mm	L mm	
400	65	300	2 013850204
600	95	300	2 013850206
800	110	320	2 013850208
1000	102	350	2 013850210
1500	116	360	2 013850215
2000	121	380	2 013850220

1385N/MR

manici di ricambio per 1385N



1385N/MR	2	013850264
1385N/MR 400-600		
1385N/MR	2	013850268
1385N/MR 800		
1385N/MR	2	013850270
1385N/MR 1000		
1385N/MR	1	013850275
1385N/MR 1500		
1385N/MR	1	013850280
1385N/MR 2000		

1390

mazzuole con battenti intercambiabili
in materiale plastico
manico in legno



UNI 7784

D mm	L1 mm	L mm	
22	70	260	5 013900022
28	85	280	5 013900028
35	95	310	5 013900035
45	107	320	4 013900045
60	128	380	2 013900060

1390/MR...

manici di ricambio per 1390



1390/MR22	2	013900222
1390/22		
1390/MR28	2	013900228
1390/28		
1390/MR35	2	013900235
1390/35		
1390/MR45	2	013900245
1390/45		
1390/MR60	2	013900260
1390/60		

1390R

battenti di ricambio per 1390



D mm	
22	4 013900122
28	4 013900128
35	4 013900135
45	4 013900145
60	4 013900160

1391

mazzuole antirimbalo
interamente rivestite in gomma



D mm	L1 mm	L mm	
35	90	280	2 013910135
50	105	320	2 013910150
55	110	355	2 013910155
65	130	380	2 013910165

1391A

mazzuole per piastrellisti
interamente rivestite in gomma



g	L1 mm	L mm	
500	100	290	2 013910205
1000	120	300	2 013910210

1392

mazzuole antirimbalo
con battenti intercambiabili
in materiale plastico
manico in acciaio



D mm	L1 mm	L mm	
30	105	300	2 013920030
35	115	305	2 013920035
40	125	310	2 013920040
50	135	325	2 013920050

1392R

battenti di ricambio per 1392



D mm	
30	4 013920230
35	4 013920235
40	4 013920240
50	4 013920250

1393

mazzuole con testa
in gomma dura



D mm	L1 mm	L mm	
50	90	315	3 013930050
60	110	340	3 013930060
70	130	370	2 013930070

1410/1 - 1410/2

utensili ad uncino
per anelli in gomma

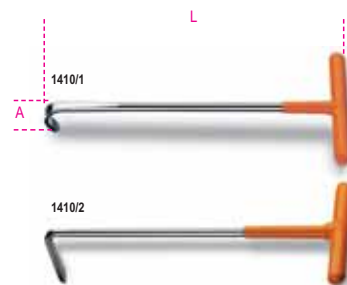

	L mm	A mm	
1410/1	205	25	2 014100001
1410/2	200	45	2 014100002

1410/M

attrezzo ad uncino
per trazionamento molle



∅ mm			
3,5		2	014100051

1428

estrattori per dadi danneggiati
con attacco quadro



M mm	□	L mm		
8	3/8	36	3	014280008
10	3/8	36	3	014280010
11	3/8	36	2	014280011
12	3/8	36	2	014280012
13	3/8	36	2	014280013
14	3/8	36	2	014280014
15	1/2	38	2	014280015
16	1/2	38	2	014280016
17	1/2	38	2	014280017
18	1/2	38	2	014280018
19	1/2	38	2	014280019



1428/SB11	1	014280111
8-10-11-12-13-14		
15-16-17-18-19		

1428L

estrattori a bussola lunghi
per dadi destrorsi danneggiati
con attacco quadro



∅ mm			
17		1	014280217
19		1	014280219
21		1	014280221



1428L/B3	1	014280303
17-19-21 mm		

1429

estrattori per viti e prigionieri danneggiati
con attacco quadro



mm	□	L mm		
2	3/8	60	3	014290002
3	3/8	60	3	014290003
4	3/8	60	3	014290004
5	3/8	60	2	014290005
6	3/8	60	2	014290006
8	1/2	70	2	014290008
10	1/2	70	2	014290010



1429/SB7	1	014290107
2-3-4-5-6-8-10		

1430/...

estrattori conici per viti
e prigionieri spezzati
in acciaio legato

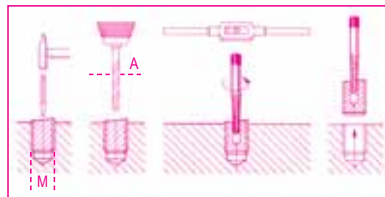

	M	A mm		
1430/1	3÷6	2,5	10	014300006
1430/2	6÷8	3,0	10	014300008
1430/3	8÷11	4,5	10	014300011
1430/4	11÷14	6,0	10	014300014
1430/5	14÷18	8,0	10	014300018
1430/6	18÷24	11,0	5	014300024
1430/7	24÷33	14,0	5	014300033
1430/8	33÷50	21,0	5	014300050



1430/S5	1	014300105
1430/1-1430/2-1430/3		
1430/4-1430/5		

1430/S6	1	014300106
1430/1-1430/2-1430/3		
1430/4-1430/5-1430/6		

1430/S8	1	014300108
1430/1-1430/2-1430/3		
1430/4-1430/5-1430/6		
1430/7-1430/8		

1434

estrattori a rulli
per viti prigioniere
con attacco quadro femmina 1/2"

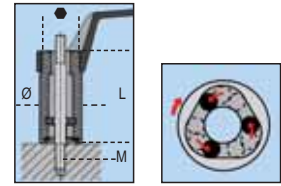

M	∅ mm	L mm	∅ mm		
6	24	65	21	4	014340106
7	24	65	21	4	014340107
8	24	65	21	4	014340108
9	29	75	22	4	014340109
10	29	75	22	4	014340110
10,5	29	75	22	4	014340111
12	29	75	22	4	014340112
14	36	75	27	4	014340114
16	36	75	27	4	014340116

1434/C4

serie di estrattori



1434/C4	1	014340140
M6 - M8 - M10 - M12		

170x100x35 mm - 1,1 kg

1434/C7

serie di estrattori



1434/C7	1	014340170
M6 - M7 - M8 - M9		
M10 - M10,5 - M12		

250x100x35 mm - 1,7 kg

1435

estrattore ad eccentrico
per viti prigioniere



∅ mm			
4÷20		1	014350001

1435R

rotella di ricambio per 1435



1435R 1 014350010

1435/1

estrattore ad eccentrico per viti prigioniere



Ø mm 19+26 1 014350002

1435/1R

rotella di ricambio per 1435/1



1435/1R 1 014350011

1438

attrezzo universale per centraggio frizioni completo di 3 coni ad espansione



1438 1 014380001

1438R

coni ad espansione di ricambio per 1438



Ø mm 14+18 5 014380101
18+21 5 014380102
22+25 5 014380103

1439/K7

cassetta giravite angolare 90° tipo lungo con lame



Dotazione valigetta:
- Giravite angolare
- 1 Testa per viti ad intaglio
- 1 Testa per bits 1/4
- 1 Testa per lame speciali
- 7 lame speciali

1439/K7 1 014390101

500x120x60 mm 825 g

1440/...

attrezzi per inserimento pistoni



	Ø mm	
1440/0	40÷75	1 014400000
1440/1	57÷125	1 014400010
1440/1A	57÷125	1 014400011
1440/2	90÷175	1 014400020
1440/2A	90÷175	1 014400021
1440/3	90÷175	1 014400030

1445/1 - 1445/2

attrezzi per segmenti di pistoni



	Ø mm	
1445/1	50÷100	1 014450001
1445/2	90÷150	1 014450002

1450GC

morsetto alzavalvole con ganasce diritte e curve



1450GC 1 014500005

1452K

morsetto alzavalvole con tre flange

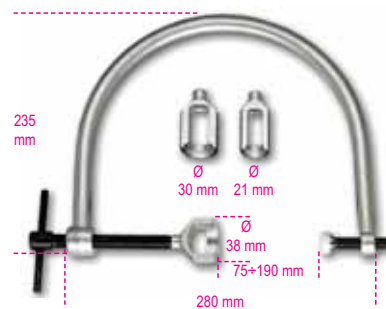

1452K 1 014520100

1454

supporto per testata motore

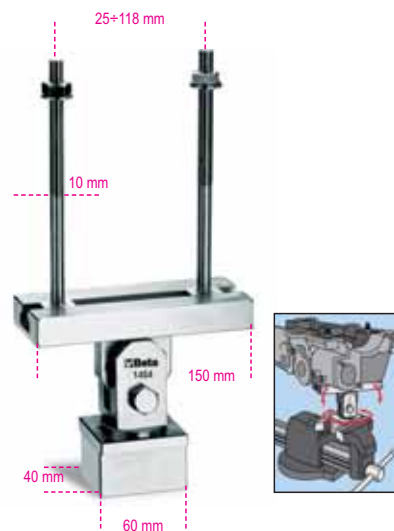

1454 1 014540001



1455SVP

smerigliavalvole pneumatico

• Pressione di utilizzo 6 Bar

CE



1455SVP 1 014550001

1455SVP/R...

ventose in gomma di ricambio per 1455SVP



1455SVP/R1 5 014550501

1455SVP/R2 5 014550502

1455SVP/R3 5 014550503

1458

pinza per anelli elastici di sicurezza SP per alberi



DIN 5417

Ø mm 30+100 3 014580001

1460F

pinza per anelli di tenuta valvole



1460F 1 014600010

1461PMS

tastatore per la ricerca del punto morto superiore



M 14x1,25 Ø mm 19,0 L mm 240 1 014610500

1461BF

blocchetti messa in fase motori Fiat-Alfa Romeo-Lancia



1461BF/N 1 014610501

1461BF/AG 1 014610502

1461BF/R 1 014610503

1461BF/B 1 014610504

1461BF/O 1 014610505

1461BF/V 1 014610506

1461BF/GR 1 014610507

1461BF/S 1 014610508

1461BF/VI 1 014610509

1461BF/BR 1 014610510

1461BF/T 1 014610511

1461BF/A 1 014610512

1461/C1

attrezzi per messa in fase motori benzina Alfa Romeo, Fiat, Lancia



1461/C1 1 014610010

380x350x35 mm - 6,0 kg

1461/C2

attrezzi per messa in fase motori Fiat Bravo, Brava, Multipla, Stilo motori 1.6 16V



1461/C2 1 014610020

380x305x40 mm - 2,5 kg

1461/C3

attrezzi per messa in fase motori Fiat Punto - Lancia Y, 1.2 16V - 1.6 16V



1461/C3 1 014610030

380x305x40 mm - 2,0 kg

1461/C4

attrezzi per messa in fase motori Diesel Fiat-Alfa, PMS 1° cilindro

Fiat 1697D - 1929D - 1910D - TD - 1910 JTD - 2387 TD



1461/C4 1 014610040

250x75x40 mm - 400 g

1461/C5

attrezzi per messa in fase motori Diesel Fiat 1.3 Multijet, Opel General Motors CDTI



1461/C5 1 014610050

450x250x45 mm - 2,6 kg

1461/C6

attrezzi per messa in fase
motori Citroën, Peugeot



1461/C6

1 014610060

≡ 420x350x35 mm - 3,5 kg

1461/C7

attrezzi per messa in fase
motori Renault 1.4 16V - 1.6 16V - Diesel



1461/C7

1 014610070

≡ 420x350x35 mm - 4,5 kg

1461/C8

attrezzi per messa in fase
motori Ford benzina e Diesel



1461/C8

1 014610080

≡ 450x250x45 mm - 2,8 kg

1461/C9

attrezzi per messa in fase
motori Opel General Motors
1.0 12V - 1.2 16V - 1.4 16V



1461/C9

1 014610090

≡ 380x305x40 mm - 1,0 kg

1461/C10

attrezzi per messa in fase
motori Audi, Seat, Skoda, Volkswagen



1461/C10

1 014610100

≡ 420x350x35 mm - 4,1 kg

1461/C11

attrezzi per messa in fase
motori Renault 1.5 - 1.9 DCI



1461/C11

1 014610110

≡ 450x250x45 mm - 2,3 kg

1461/C12

attrezzi per messa in fase
motori Fiat 1.9 JTD 16V Multijet



1461/C12

1 014610120

≡ 380x305x40 mm - 1,8 kg

1461/C14

attrezzi per messa in fase
motori BMW VANOS
e Valvetronic



1461/C14

1 014610140

≡ 450x250x45 mm - 4,0 kg

1461/C15

attrezzi per messa in fase motori
BMW Valvetronic
(da usare con il 1461/C14)



1461/C15

1 014610150

≡ 420x350x35 mm - 4,0 kg

1461/C16

attrezzi per messa in fase motori
BMW 2.0-3.0 Diesel
completo di estrattore pompa



1461/C16 1 014610160
380x305x40 mm - 4,3 kg

1461/C17

attrezzi per messa in fase motori
Volkswagen, Seat, Skoda, 1.2 6-12V



1461/C17 1 014610170
250x190x100 mm - 1,5 kg

1461/C18

attrezzi per messa in fase motori Volkswagen,
Audi, Skoda 1.4 - 1.6 FSI



1461/C18 1 014610180
380x305x40 mm - 1 kg

1461/C19

attrezzi per messa in fase motori Ford
Duratorq 2.0-2.2-2.4 DIESEL



1461/C19 1 014610190
380x305x40 mm - 1,5 kg

1461R6/K3

attrezzi per messa in fase motori
Peugeot e Citroën



1461R6/K3 1 014610601

1463/KIT

kit attrezzatura per blocco pulegge
distribuzione



1463/KIT 1 014630001
280x140x75 mm - 1,2 kg

1467

strumento estrazione liquido freni



Pressione min 5 bar, Max 11,5 bar
1467 1,5 1 014670001

1467E

strumento elettronico
per la sostituzione del liquido frenante



CE

- Pompa regolabile fino a 5,8 bar
- Possibilità di impiego sui sistemi ABS ETS ESP
- Dotato di dispositivo automatico di blocco in caso di esaurimento liquido frenante presente nel contenitore di riempimento
- Nessun utilizzo di aria compressa
- Alimentazione 220/230 V con fusibile di protezione
- Fornito di valigetta con tappi adattatori (ø 45mm, 79 mm + 1 universale) 1467/KE
- Lunghezza tubo 3,5 m; lunghezza cavo 5,5 m
- Fornito con tanica di capacità max 5l 1467E/RT

1467E 1 014670021

1467/KE

serie di tappi adattatori
in valigetta di plastica
(incluso nel 1467E)



1467/KE 1 014670022

1467E/RT

tanica da 5 litri per 1467E
(incluso nel 1467E)



1467E/RT 1 014670023

1468/F...

kit spazzole rotative pulizia mozzi ruota

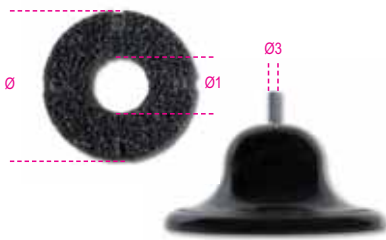

	Ø1	Ø2	Ø3	N		
	mm	mm	mm	mm	○	
1468/F30	40-53	14	8	12		1 014680030
1468/F160	160	60	10	2		1 014680160
1468/F200	200	85	10	1		1 014680200

1468/P

dischi abrasivi



	Ø	Ø1		
	mm	mm		
1468 40/P30	40	14		1 014680031
1468 50/P30	53	14		1 014680032
1468/P160	160	58		1 014680161
1468/P200	200	83		1 014680201

1468N

attrezzi per sostituzione piattelli valvole

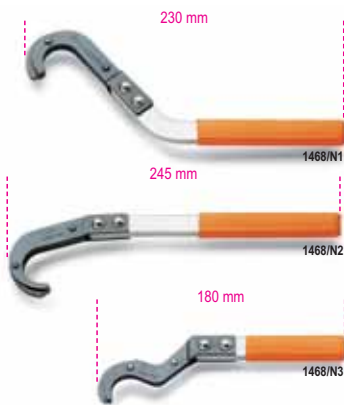

1468N/1		1 014680011
1468N/2		1 014680012
1468N/3		1 014680013

1469

pinza regolabile autobloccante, per occlusione tubi impianto frenante



1469		1 014690001
------	--	-------------

1469C

svasatore tubi freno in cassetta



SAE J514
SAE J1065
DIN 74234

Ø		
3/16" - 4,75 mm		1 014690100
≡ 350x300x105mm - 6 Kg		

1469C-R

kit matrici e puntali per svasatura tubi freno



SAE J514
SAE J1065
DIN 74234

	Ø		
1469C-R 3/16	3/16"		1 014690501
1469C-R 4,75	4,75 mm		1 014690502
1469C-R 6	6 mm		1 014690503
1469C-R 8	8 mm		1 014690504
1469C-R 10	10 mm		1 014690505
1469C-R 12	12 mm		1 014690506

1469D

tester liquido freni digitale in valigetta di plastica



- Permette di testare i liquidi frenanti DOT
- Misura il punto di ebollizione del liquido freni
- Test automatico, con commutazione della scala in gradi °C/°F
- Precisione: 100 - 180 °C +/- 3% > 180 °C +/- 5%
- Alimentazione: 12 Volt (batteria del veicolo)

1469D		1 014690110
≡ 310x230x100 mm - 1,1 kg		

1470

pinze per molle freni a tamburo

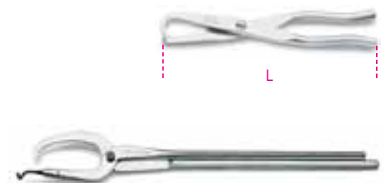

L		
mm		
210		1 014700001
330		1 014700002
540		1 014700010

1471

pinza per molle freni a tamburo



L		
mm		
330		1 014710001

1471A

pinza per cavo freno a mano



A max	B	
mm	mm	
45	5	2 014710010

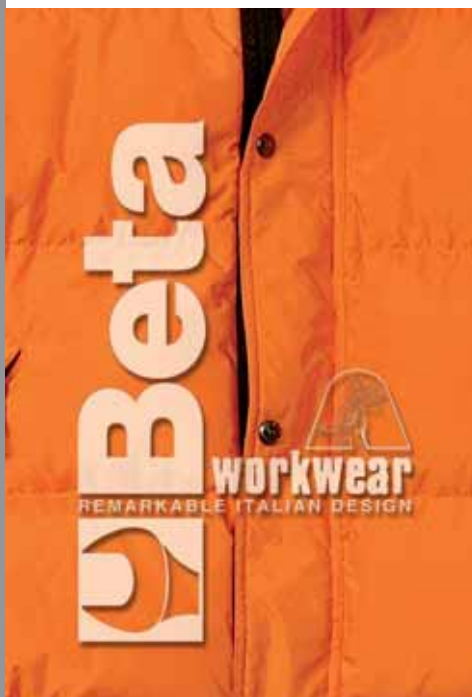

1471U

assortimento attrezzi per ruotare e arretrare pistoncini freni destrorsi e sinistrorsi



1471U 1 014710050

410x300x100 mm - 4,4 kg

1471PN/50

utensile pneumatico per arretrare e ruotare i pistoncini dei freni a disco destrorsi e sinistrorsi con accessori



1471PN/50 1 014710061

350x310x85 mm - 3,2 kg

1471M/50

martinetto pneumatico per arretrare e ruotare i pistoncini dei freni a disco destrorsi e sinistrorsi



Ø mm Kg Bar 50 150 5÷8 1 014710069

1471D

arretratore pistoncini freni a disco con pinze chiuse

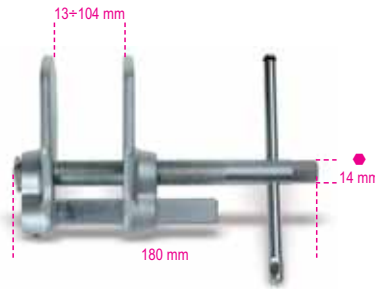

1471D 1 014710300

1471/S4

serie di quattro pinze per ritenzione pistoncini freni a tamburo



1471/S4 1 014710250

1472

pinza per anelli stringitubo



1472 1 014720001

1472AU

pinza automatica per anelli stringitubo



Ø mm 18÷53 1 014720100

1472AU/P

pinza automatica con prolunga per anelli stringitubo



L = 630 mm

Ø mm 18÷54 1 014720105

1472FS

pinza per fascette a scatto Clic®



1472FS 1 014720110

1473

pinza per collari OETIKER®



1473 1 014730001

1473A

pinza con reggiasola per collari OETIKER®



1473A 1 014730010

1474

pinza per cappucci candele d'accensione



Ø min mm 12,5 2 014740001

1474A

pinza per cappucci candele
d'accensione a becchi piegati 50°

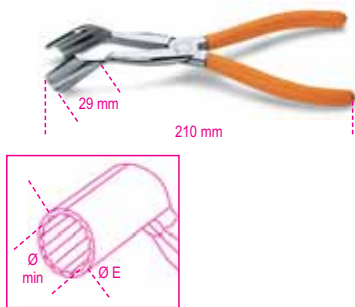

Ø min mm	Ø E mm	2	014740005
16	21		

1474B

pinza per cappucci candele
d'accensione a becchi piegati 25°

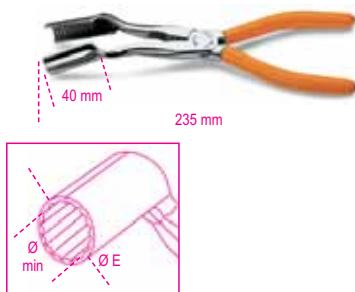

Ø min mm	Ø E mm	2	014740008
16	20		

1474L

pinza per cappucci candele
d'accensione a becchi lunghi
piegati 15°

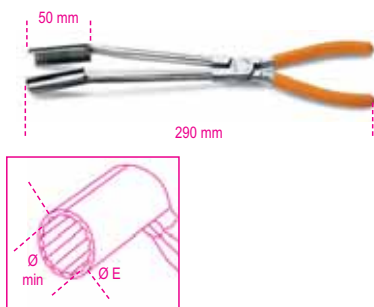

Ø min mm	Ø E mm	2	014740010
14	20		

1474DL

pinza per cappucci candele
d'accensione a becchi lunghi
manici ricoperti con 2 strati in PVC



Ø min mm	Ø E mm	1	014740015
30	95		

1475L

pinza a becchi mezzotondi lunghissimi
cromata lucida con impugnatura
a "pistola", manici ricoperti
con 2 strati in PVC

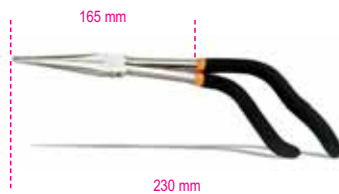

1475L	1	014750005

1475U

pinza universale cromata lucida
con impugnatura a "pistola"
manici ricoperti con 2 strati in PVC



1475U	1	014750010

1476

pinza regolabile autobloccante
per taglio tubi di scarico

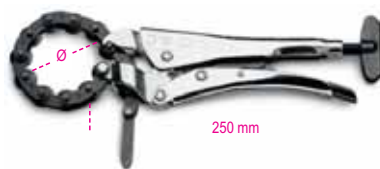

Ø min mm	Ø max mm	1	014760001
19	75		

1476/RC

catena di ricambio per 1476



1476/RC	1	014760010

1476A

pinza per taglio tubi
di scarico



Ø min mm	Ø max mm	1	014760005
30	95		

1476A/RC

catena di ricambio per 1476A



1476A/RC	1	014760015

1476B/1

tenditore per molle
collettori di scarico

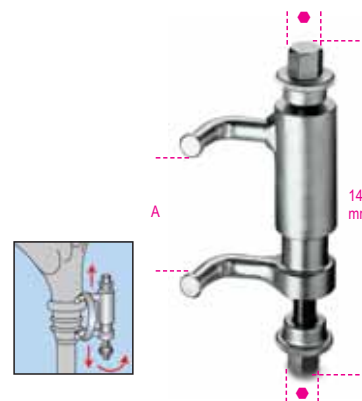

A min+max mm	● mm	1	014760020
40+70	13		

1476C/1 - 1476C/2

attrezzi espansori per tubi di scarico



1476C/1	1	014760101
Ø 28+42 mm L = 131 mm L1 = 51 mm		

1476C/2	1	014760105
Ø 38+62 mm L = 164 mm L1 = 64 mm		

1477

chiavi poligonali
per dadi tendicinghia



Ø mm	1	014770013
13		
15		014770015



1477K/7

kit chiave curva a cricchetto reversibile con inserti



- 2 Inserti Torx® T40-T45
- 1 Inserto XZN® 10
- 1 Inserto esagonale 8 mm
- 3 Inserti poligonali 10-12-13 mm

1477K/7 L
mm 250 1 014770051

1478

pinza per estrazione pioli



1478 265 mm 1 014780001

1479

estrattore per pioli

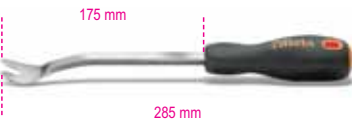

1479 175 mm 285 mm 4 014790001

1479TF

estrattore per pioli lama teflonata



1479TF 138 mm 50 mm 256 mm 2 014790005

1479RB/1

raschietto a battere tipo diritto



1479RB/1 100 mm 30 mm 235 mm 1 014790315

1479RB/2

raschietto a battere tipo piegato



1479RB/2 100 mm 30 mm 235 mm 1 014790320

1479RB/3

raschietto a battere tipo piatto



1479RB/3 100 mm 50 mm 235 mm 1 014790310

1479/S3

serie di 3 raschietti a battere



1479/S3 275x185x53 mm - 600 g 1 014790300

1479U/13

levapioli lama inox



1479U/13 95 mm 230 mm 2 014790010

1479U/32

levapioli lama inox



1479U/32 95 mm 235 mm 2 014790015

1479V/13

levapioli lama inox



1479V/13 95 mm 230 mm 2 014790020

1479V/32

levapioli lama inox



1479V/32 95 mm 230 mm 2 014790025

1479U/DP

levapioli lama inox, doppia piega



1479U/DP 120 mm 260 mm 2 014790030

1479N/S5

kit di 5 levapioli in nylon



1479N/S5 1 014790251

Beta
Collection

1481/...

morsetti per occlusione tubi e manicotti



	Ø max mm		
1481/10	10	4	014810001
1481/15	15	4	014810002
1481/25	25	2	014810003
1481/45	45	2	014810004

1481/S4

serie di 4 morsetti



1481/S4	1	014810020
1481/10-1481/15		
1481/25-1481/45		

1481PL/A

pinza in plastica per occlusione tubi e manicotti



Ø mm			
8÷15	3	014810110	

1481PL/B

pinza in plastica per occlusione tubi e manicotti



Ø mm			
15÷25	3	014810120	

1481PL/C

pinza in plastica per occlusione tubi e manicotti



Ø mm			
25÷45	3	014810130	

1481PL/S3

serie di 3 pinze in plastica per occlusione tubi e manicotti

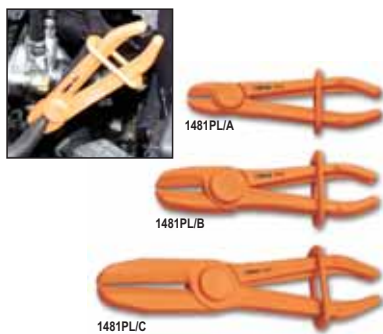

1481PL/S3	1	014810200
1481PL-A Ø 8÷15 mm		
1481PL-B Ø 15÷25 mm		
1481PL-C Ø 25÷45 mm		

1482/8 - 1482/10

pinze per raccordi rapidi tubi carburante

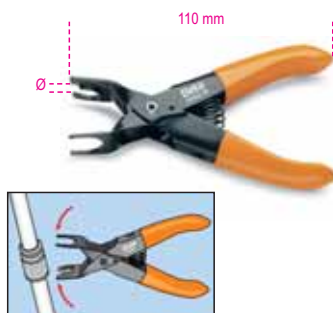

	Ø mm		
1482/8	8	2	014820008
1482/10	10	2	014820010

1482A

pinza per raccordi rapidi tubi carburante

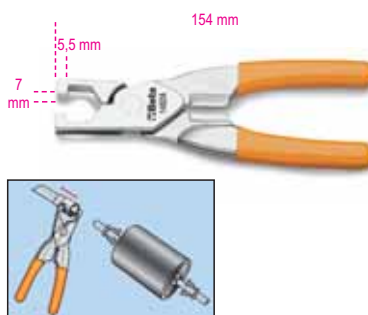

1482A	2	014820020
-------	---	-----------

1482G/...

chiavi regolabili per ghiera per galleggianti serbatoio carburante

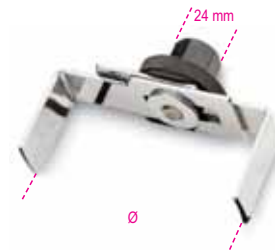

	Ø mm		
1482G/1	85÷120	1	014820025
1482G/2	118÷165	1	014820030
1482G/3	160÷205	1	014820035

1485/KIT

kit attrezzi per controllo tensione cinghia distribuzione



1485/KIT	1	014850100
230x140x75 mm - 580 g		

1485R

attrezzo per rotazione pulegge distribuzione in acciaio forgiato con 2 coppie di puntali



Ø mm	Ø1 mm	L mm		
30÷120	10 - 17	500	1	014850025

1485R/P10

coppie di puntali



1485R/P10	1	014850035
-----------	---	-----------

Beta

1485R/P17

coppie di puntali

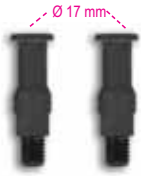

1485R/P17 1 014850038

1486T

chiave per pulegge a gola trapezoidale e a V



Ø mm 40÷140 1 014860001

1486M

chiave per pulegge multigola



Ø mm 40÷140 1 014860002

1488 - 1488L

chiave snodata a catena doppia per filtri olio

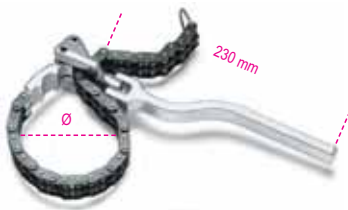

Ø mm 1488 60÷110 1 014880001
1488L 60÷160 1 014880050

1488/1

chiave a catena doppia sottile per filtri olio



Ø mm 60÷110 1 014880010

1489/33

chiave per ruota libera puleggia alternatore Bosch



1489/33 33 3 014890010

1489/33P

chiave per ruota libera puleggia nuovo alternatore Bosch FIAT Grande Punto

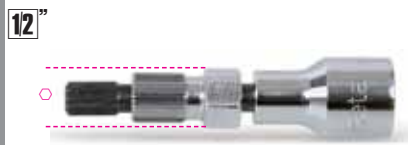

Ø mm 10 15 31 1 014890015

1489/Y

chiave per ruota libera puleggia alternatori Nippondenso



Ø mm 32 3 014890040

1489R

chiave per ruota libera puleggia alternatore Renault



1489R 1 014890020

1490/1 - 1490/2

chiavi a nastro per filtri olio

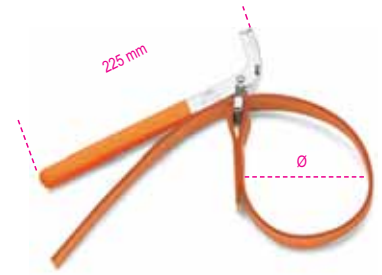

Ø max mm 1490/1 160 1 014900001
1490/2 240 1 014900002

1491

chiave a nastro metallico regolabile per filtri olio



Ø mm 65÷110 2 014910001

1491R

nastro metallico di ricambio per 1491



1491R 10 014910010

1491C

pinza regolabile per filtri olio



Ø mm 60÷100 L mm 300 1 014910030

1492/1 - 1492/2

chiavi regolabili per filtri olio



Ø mm 1492/1 60÷80 1 014920001
1492/2 80÷110 1 014920002



1493/A

chiave a bussola per filtri olio

Numero 8 lati



1493/A 1 014930001

1493/B

chiave a bussola per filtri olio e gasolio

Numero 14 lati



1493/B 1 014930005

1493/C

chiave a bussola per filtri olio

Numero 10 lati



1493/C 1 014930010

1493/D

chiave a bussola per filtri olio

Numero 15 lati



1493/D 1 014930015

1493/E - F - G

chiavi a bussola per filtri olio

N = numero lati



	D mm	N	
1493/E	65	14	2 014930020
1493/F	74	15	2 014930025
1493/G	90	15	2 014930030

1493/L - M - P - R

chiavi a bussola per filtri olio Purflux®

N = numero lati



	A mm	D mm	N	
1493/L	44	66	6	2 014930040
1493/M	45	76	6	1 014930050
1493/P	50	86	9	1 014930065
1493/R	50	96	9	1 014930070

1493T

chiave autoregolabile a tre bracci per filtri olio



Ø mm 60+120 1 014930075

1493/S-U

chiave autoregolabile a tre bracci per filtri olio destrorsa-sinistrorsa



	□	Ø mm	
1493/S	3/8-1/2	80-115	1 014930074
1493/U	1/2	105-165	1 014930076

1493J

chiave per filtri gasolio Multijet Fiat, Lancia, Opel CDTI, Suzuki DDiS

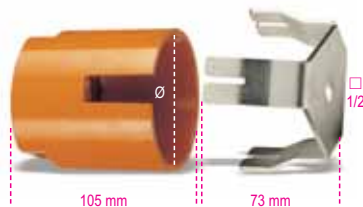

Ø mm 90 1 014930080

1493Z/1 - 2 - 3

chiavi autoserranti per filtri olio



	Ø mm	
1493Z/1	60÷80	1 014930090
1493Z/2	80÷100	1 014930095
1493Z/3	100÷125	1 014930100

1494

chiavi per tappi olio motore



mm	L mm	
8x10	32	1 014940001
8x3/8	32	1 014940002
10x11	32	1 014940003
12x13	32	1 014940004
14x17	32	1 014940005
19	24	1 014940006

mm	
8x10	■ Citroën-Honda-Peugeot-Renault
8x3/8	● Opel-Vauxhall
10x11	● Ford-Peugeot/Talbot
12x13	● Fiat-Lancia
14x17	● VW-Audi-BMW-Mercedes
19	● VW-Golf

1494PB

bussola di manovra per chiavi tappi olio 1494



17 1 014940010

1494/C6

serie di 6 chiavi per tappi olio con bussola di manovra



1494/C6 1 014940020

1494	■ 8x10 - ● 8x3/8 - ● 10x11
1494PB	● 12x13 - ● 14x17 - ● 19 mm

130x55x40 mm - 430 g

1494/C14

assortimento di 14 utensili per cambio olio

12^{''}



1494/C14 1 014940100

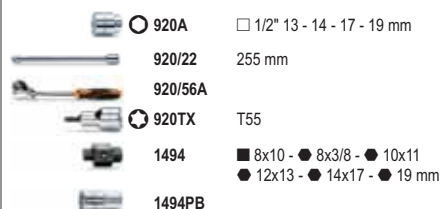

335x145x60 mm - 2,7 kg

1494XZN

chiave a bussola con profilo XZN® per tappi olio

12^{''}



1494XZN 1 014940040

1496/A

chiavi per tappi olio motore



10 x 10 mm 3 014960001

1496/B

chiavi per tappi olio motore



10 x 8 mm 3 014960005

1496/C

chiavi per tappi olio motore



8 x 10 mm

3 014960010

1496/D

chiavi per tappi olio motore



10 x 12 mm

3 014960015

1498

provatensione

CE

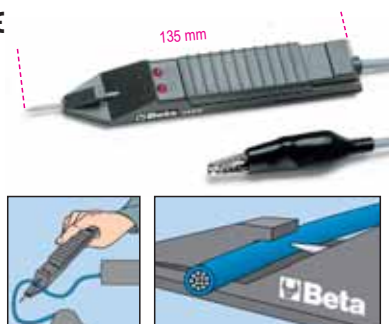

3÷48V

2 014980100

1498A/12

avviatore per autovetture 12 V



DATI TECNICI

- Corrente di spunto 2200 A
- Cicli di ricarica utili 400
- Batteria ermetica al piombo electrolyte solido (AGM)

1 014980200

1498A/12

1498A/24

avviatore per autovetture e veicoli commerciali 12-24 V



DATI TECNICI

- Corrente di spunto 3400 A (12 V), 1700 A (24 V)
- Cicli di ricarica utili 400
- Batteria ermetica al piombo electrolyte solido (AGM)

1498A/24

1 014980210

1498CB/30

caricabatterie elettronico moto



DATI TECNICI

- Alimentazione: 230V
- Potenza: 20W
- Tensione: 6/12V
- Corrente di carica: 1A
- Capacità nominale di riferimento: 1-40Ah
- ACCESSORI IN DOTAZIONE:
 - Pinze di collegamento
 - Connettore con terminali ad occhielli
 - Connettore per presa accendisigari

1498CB/30

1 014980303

150x65x36 mm - 400 g

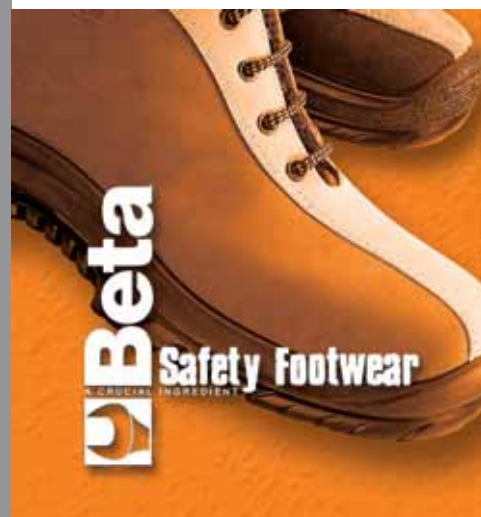

1498CB/80

caricabatterie elettronico auto-moto



CE



DATI TECNICI

Alimentazione: 230V

Potenza: 60W

Tensione: 12V

Corrente di carica: 3,5A

Capacità nominale di riferimento: 1-110Ah

ACCESSORI IN DOTAZIONE:

- Pinze di collegamento
- Connettore con terminali ad occhielli
- Connettore per presa accendisigari

1498CB/80

1 014980308

188x82x45 mm - 600 g

1498CB/120

caricabatterie elettronico auto-veicoli commerciali



CE



DATI TECNICI

Alimentazione: 230V

Potenza: 110W

Tensione: 12V

Corrente di carica: 6,5-1A

Capacità nominale di riferimento: 4-190Ah

ACCESSORI IN DOTAZIONE:

- Pinze di collegamento
- Connettore con terminali ad occhielli
- Connettore per presa accendisigari

1498CB/120

1 014980312

220x98x55 mm - 850 g

1498TB/W

tester digitale wireless per batterie e impianti di ricarica/avviamento in valigetta di plastica



CE

- Misura lo stato di carica, la capacità e l'efficienza della batteria
- Verifica l'impianto di avviamento
- Verifica il sistema di ricarica

DOTATO DI:

- Protezione corto circuito
- Sistema di compensazione della temperatura
- Software in 6 lingue (I, EN, F, ES, PL, NL)
- Modulo Wireless per trasmissione dati alla stampante Beta 1498ST/W

DATI TECNICI

• Test di batterie 12 Volt.

• Standard SAE, EN, IEC, DIN o JIS.

• Capacità: SAE 30-1500; EN 30-1500; IEC 30-1500; DIN 30-1500.

• Sistemi di ricarica 12 e 24 V (in serie).

1498TB/W

1 014980071

1498ST/W

stampante wireless con ricevitore (per 1498TB/W e 960TP)



CE

DATI TECNICI

• Ricezione dati fino a 30 metri in campo aperto

• Stampa termica

• Risoluzione: 203 dpi

• Velocità di stampa (mm/sec): 60

• Larghezza carta: 58 mm

1498ST/W

1 014980500

1499

stetoscopio



230 mm

1499

1 014990001

1500N/...

estrattori universali a 2 griffe scorrevoli

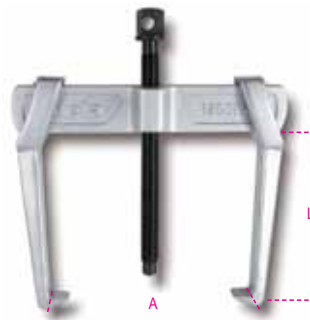

	L mm	A mm		
1500N/0	70	65	1	015000600
1500N/1	100	90	1	015000601
1500N/2	100	120	1	015000602
1500N/3	150	170	1	015000603
1500N/4	150	220	1	015000604
1500N/5	205	290	1	015000605
1500N/6	205	360	1	015000606



1500N/SP6	1	015000626
1500N/0-1500N/1-1500N/2		
1500N/3-1500N/4-1500N/5		
1500N/SPV	1	015000006

1500N/G...

griffe per estrattori 1500N



	L mm		
1500N/G0	70	2	015000650
1500N/0			
1500N/G1-2	100	2	015000651
1500N/1-2			
1500N/G3-4	150	2	015000653
1500N/3-4			
1500N/G5-6	205	2	015000655
1500N/5-6			

1500/...

estrattori universali
a due griffe

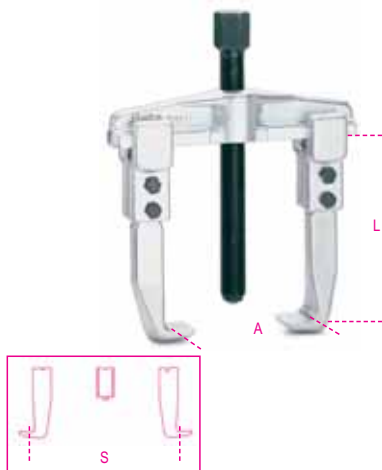

	L mm		
1500/7	205	1	015000107
1500/8	230	1	015000108

	A mm	S mm
1500/7	110÷520	195÷600
1500/8	170÷640	260÷715

1500G/...

griffe tipo normale
per 1500 e 1580/8I



	L mm		
1500G/5	205	2	015000115
1500/7			
1500G/8	230	2	015000117
1500/8			
1580/8I			

1500GL/...

griffe tipo lungo
per 1500 e 1580/8I



	L mm		
1500GL/5A	300	1	015000215
1500/7			
1500GL/5B	400	1	015000216
1500/7			
1500GL/5C	500	1	015000217
1500/7			
1500GL/8A	300	1	015000227
1500/8			
1580/8I			
1500GL/8B	400	1	015000228
1500/8			
1580/8I			
1500GL/8C	500	1	015000229
1500/8			
1580/8I			

1501/1 - 2 - 3

estrattori a griffe sottili

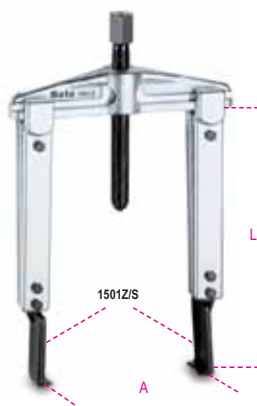

	L mm		
1501/1	100	1	015010101
1501/2	200	1	015010102
1501/3	250	1	015010103

	A mm
1501/1	25÷130
1501/2	25÷130
1501/3	25÷130

1501G/1 - 2 - 3

coppie di griffe per 1501

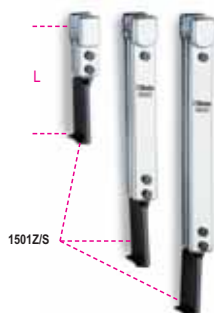

	L mm		
1501G/1	100	1	015010111
1501G/2	200	1	015010112
1501G/3	250	1	015010113

1501Z/S - P - R

terminali per griffe 1501G



	A mm	D mm		
1501Z/S	2,0	27	2	015010211
1501Z/P	3,6	27	2	015010212
1501Z/R	3,6	14	2	015010213

1505

estrattori bracci tergitristallo



	A mm		
1505	30÷35	1	015050010

1506

estrattore autoserrante
a due griffe



	A mm		
1506	10÷50	1	015060001

1508/1 - 1508/2

estrattori a due griffe
tipo leggero



	H mm		
1508/1	105	1	015080001
1508/2	130	1	015080002

	A mm	L1 max mm
1508/1	6÷100	85
1508/2	10÷140	110

1511/1 - 2 - 3

estrattori a due griffe reversibili per esterni

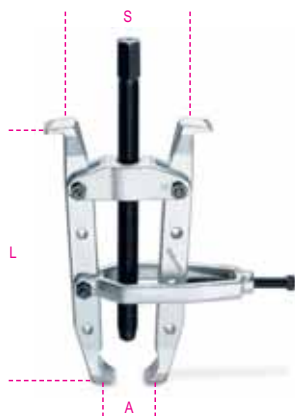

	L mm		
1511/1	235	1	015110001
1511/2	350	1	015110002
1511/3	405	1	015110003

	A mm	S mm
1511/1	20÷100	65÷95
1511/2	40÷150	103÷190
1511/3	40÷150	103÷175

1515/1 - 2 - 3

estrattori a due griffe oscillanti



	L mm		
1515/1	85	1	015150101
1515/2	85	1	015150102
1515/3	105	1	015150103

	A max mm	S max mm
1515/1	60	40
1515/2	70	65
1515/3	90	85



1516/1 - 2 - 3

estrattori a tre griffe oscillanti



	L mm		
1516/1	85	1	015160001
1516/2	85	1	015160002
1516/3	105	1	015160003

	A max mm	S max mm
1516/1	60	40
1516/2	70	65
1516/3	90	85

1518/...

estrattori a tre griffe



	H mm		
1518/1	105	1	015180001
1518/2	135	1	015180002
1518/3	235	1	015180003
1518/4	270	1	015180004
1518/5	270	1	015180005
1518/6	270	1	015180006

	A mm	S max mm
1518/1	24÷100	105
1518/2	32÷160	150
1518/3	40÷220	220
1518/4	80÷250	240
1518/5	80÷300	350
1518/6	80÷350	400

1520/1 - 1520/2

estrattori a due griffe reversibili



	L mm		
1520/1	135	1	015200101
1520/2	235	1	015200102

	A max mm	S max mm
1520/1	110	85
1520/2	160	140

1521/1 - 1521/2

estrattori a tre griffe reversibili



	L mm		
1521/1	135	1	015210101
1521/2	235	1	015210102

	A max mm	S max mm
1521/1	110	85
1521/2	160	140

1529

estrattore per pulegge multigola



	min Ø max mm	H mm	L mm		
24÷240	140	90		1	015290000

260x210x60 mm - 2,6 kg



1530/3 - 1530/4

estrattori per mozzi ruote



	A max mm		
1530/3	225	1	015300030
1530/4	225	1	015300040

	D mm	n.
1530/3	18	3
1530/4	18	4

1530B

braccio per estrattore 1530



1530B	1	015300011
-------	---	-----------

1531/3 - 4 - 5

estrattori per mozzi e tamburi ruote



	A max mm		
1531/3	250	1	015310001
1531/4	250	1	015310002
1531/5	250	1	015310003

	D mm	L mm	L1 mm	n.
1531/3	14-18-22	210	135	3
1531/4	14-18-22	210	135	4
1531/5	14-18-22	210	135	5

1531B

braccio per estrattore 1531



1531B	1	015310201
-------	---	-----------

1532

utensile per rimozione guarnizioni



1532	2	015320001
------	---	-----------

1533/...

tiranti per separatori 1534

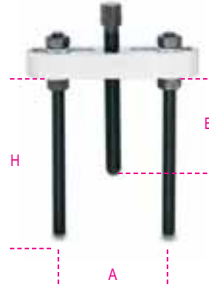

	H mm		
1533/2	150	1	015330002
1533/3	210	1	015330003
1533/4	315	1	015330004
1533/5	305	1	015330005

	A min mm	A max mm	B max mm
1533/2	45	134	110
1533/3	55	205	175
1533/4	90	260	170
1533/5	100	360	235

1533PR/1 - 2 - 3

prolunghe per tiranti 1533



1533PR/1	1	015330011
1533/2		
1533PR/2	1	015330012
1533/3		
1533PR/3	1	015330013
1533/4-5		

1534/...

separatori

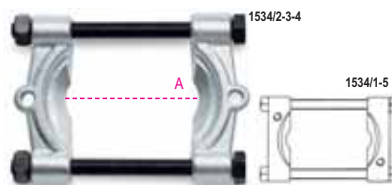

	A max mm		
1534/1	1533/2	1	015340001
1534/2	1533/2	1	015340002
1534/3	1533/3	1	015340003
1534/4	1533/4	1	015340004
1534/5	1533/5	1	015340005

	A max mm
1534/1	70
1534/2	85
1534/3	115
1534/4	150
1534/5	245

1535/C...

estrattori combinati



1535/C1	1	015350001
---------	---	-----------

1533/2		
1533PR/1		
1534/1		
260x180x40 mm		2,5 kg

1535/C2	1	015350002
---------	---	-----------

1533/2		
1533PR/1		
1534/2		
260x180x40 mm		2,8 kg

1535/C3	1	015350003
---------	---	-----------

1533/3		
1533PR/2		
1534/3		
380x280x55 mm		8,0 kg

1535/C4	1	015350004
---------	---	-----------

1533/4		
1533PR/3		
1534/4		
420x380x65 mm		14,8 kg

1535/C5	1	015350005
---------	---	-----------

1533/5		
1533PR/3		
1534/5		
530x510x85 mm		27,4 kg

1539

tiralamiere a percussione



1539	1	015390001
------	---	-----------

1540

estrattore a percussione

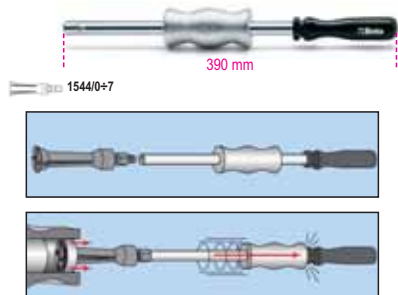

1540	M10	1	015400001
------	-----	---	-----------

1542/1 - 1542/2

estrattori per griffe ed espansori



	A max mm		
1542/1	75	1	015420001
1544/0÷7			
1542/2	130	1	015420002
1544/9C			
1544/10C			

1544/...

espansori a settori per interni

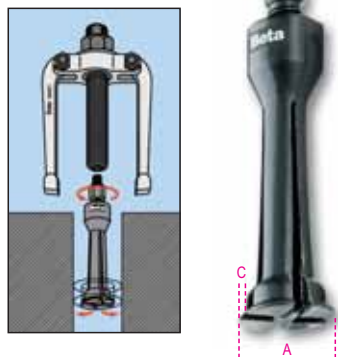

	C mm		
1544/0	0,25	M10	1 015440100
A= 5÷7 mm			
1544/A	0,80	M10	1 015440105
A= 7÷9 mm			
1544/1	0,80	M10	1 015440110
A= 9÷12 mm			
1544/2	1,15	M10	1 015440120
A= 13÷17 mm			
1544/2B	1,00	M10	1 015440121
A= 14÷19 mm			

	C mm		
1544/3	1,70	M10	1 015440130
A= 16÷21 mm			
1544/4	1,65	M10	1 015440140
A= 20÷25 mm			
1544/5	2,00	M10	1 015440150
A= 25÷30 mm			
1544/6	3,00	M10	1 015440160
A= 30÷37 mm			
1544/7	3,80	M10	1 015440170
A= 38÷45 mm			
1544/9C	2,60	G 3/8"	1 015440189
A= 40÷75 mm			
1544/10C	7,30	G 3/8"	1 015440199
A= 70÷115 mm			

1545/C5

estrattore 1542/1 con 5 espansori 1544



1545/C5	1	015450001
---------	---	-----------

1542/1	● 24 mm
1544/1	9÷12 mm
1544/2	13÷17 mm
1544/3	16÷21 mm
1544/4	20÷25 mm
1544/5	25÷30 mm

265x180x45 mm - 2,4 kg

1548/...

pressori a vite per estrazione cuscinetti



	L mm		
1548/1	130	1	015480001
x 1548G4/1-2			
1548/2	170	1	015480002
x 1548G4/3÷5			
1548/3	185	1	015480003
x 1548G4/4÷6			
1548/4	220	1	015480004
x 1548G4/5÷7			
1548/5	220	1	015480005
x 1548G4/6÷8			

1548G4/...

griffe per pressori 1548

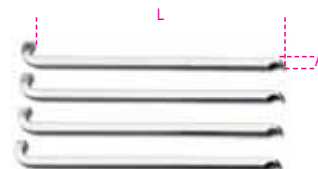

	L mm	A mm		
1548G4/1	140	4	1	015480011
1548/1				
1548G4/2	140	5	1	015480012
1548/1				
1548G4/3	170	6	1	015480013
1548/2				
1548G4/4	170	6	1	015480014
1548/2-3				
1548G4/5	175	7	1	015480015
1548/2÷5				
1548G4/6	175	8	1	015480016
1548/3÷5				
1548G4/7	225	9	1	015480017
1548/4				
1548G4/8	225	10	1	015480018
1548/4-5				

1548/C5

estrattori per cuscinetti



1548/C5	1	015480019
---------	---	-----------

1548	/1 - /2 - /3 - /4 - /5
1548G4	/1 - /2 - /3 - /4 - /5 - /6 - /7 - /8

290x220x65 mm - 8,1 kg



1550/1

compressore pneumatico per molle ammortizzatori Mac Pherson ed equivalenti

- Pressione d'utilizzo 6Bar - Max. 8Bar
- Consumo aria medio 225 l/min

CE



1600 mm

600 mm

1 015500001

1550/PS

piattello di supporto e contenimento ammortizzatore per 1550/1



1 015500057

1550/SR...

staffa di ricambio per 1550/1

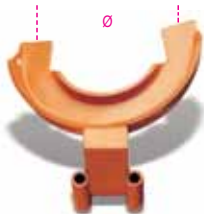

Ø mm

1550/SR90	50÷90	1 015500050
1550/SR150	90÷150	1 015500051
1550/SR175	120÷175	1 015500052
1550/SR205	130÷205	1 015500053

1550/MRC

staffa per ammortizzatori Mercedes W203, W209 (classe C e E)



1 015500061

1555DS

pressore per molle ammortizzatori MacPherson ed equivalenti

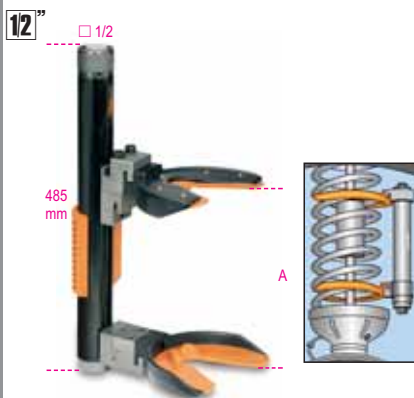

A min+Max mm	Ø min+Max mm	1 015550000
50÷350	80÷200	

1555S/MRC-C

coppie di staffe per ammortizzatori Mercedes W203, W209 (Classe C e E)



1 015550301

1555S/BMW-RNT

coppie di staffe per ammortizzatori BMW E39, E46 e Renault Megane II



1 015550303

1555B

pressore telescopico per molle ammortizzatori

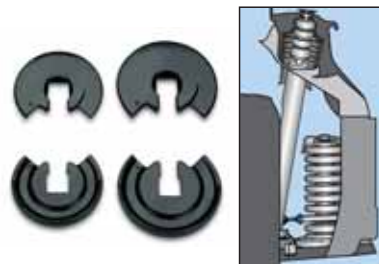

A min+Max mm	Ø min+Max mm	1 015550200
110÷317	80÷141	

1555C

pressore telescopico per molle ammortizzatori



Ø min+Max mm	A min+Max mm	N Kg	1 015550202
90÷160	80÷225	25000 2500	

1555M

morsa da banco per bloccaggio ammortizzatore

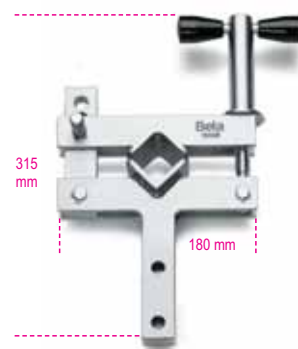

1 015550010

1556/1A

pressore per molle ammortizzatori

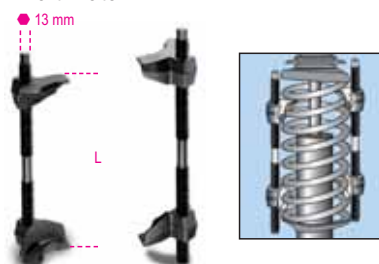

min L max mm	1 015560101
65÷320	

1556/2A

pressore per molle
ammortizzatori

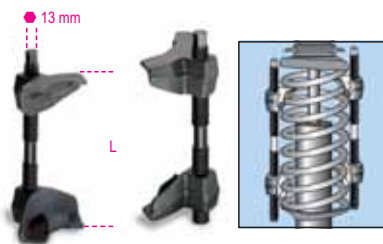

min L max mm		
65÷200	1	015560102

1556/3A

pressore per molle
ammortizzatori

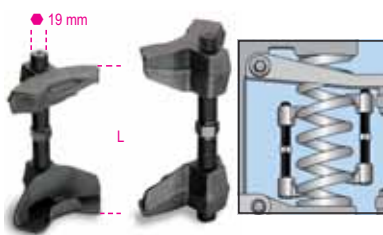

min L max mm		
87÷170	1	015560103

1557/S3

serie di 3 chiavi
per ghiera ammortizzatori



1557/S3	1	015570010
---------	---	-----------

1559

estrattore per snodi sferici



	A max mm	Ø mm		
1559/22	50	18÷22	1	015590001
1559/36	90	36	1	015590036
1559/45	115	45	1	015590045

1559V/8T

vite idraulica per estrattore snodi sferici
1559/36 e 1559/45

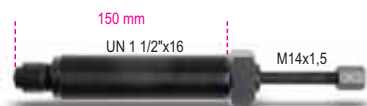

N Kg		
80000	1	015590145
8000		

1560/1 - 1560/2

estrattori per snodi sferici
modello professionale



	A mm		
1560/1	12÷50	1	015600001
1560/2	60÷85	1	015600002

1560A

estrattore per snodi sferici



1560A	1	015600601
-------	---	-----------

1561/...

estrattori per snodi sferici



	L mm	A mm	Ø mm		
1561/1	39	36,6	18	1	015610001
1561/2	47	45,7	25	1	015610002
1561/3	63	62	30	1	015610003
1561/4	75	63	40	1	015610004

1562

estrattore per snodi sferici



A max mm	Ø mm	● mm		
75	39	26	1	015620039

1565/1 - 2 - 3

estrattori a percussione
per snodi sferici



	Ø mm	L1 mm		
1565/1	18	65	1	015650001
1565/2	23	65	1	015650002
1565/3	30	88	1	015650003

1566

chiavi per smontaggio
braccetti sterzo



1566	1	015660001
------	---	-----------

1566GO

estrattore per giunti omocinetici

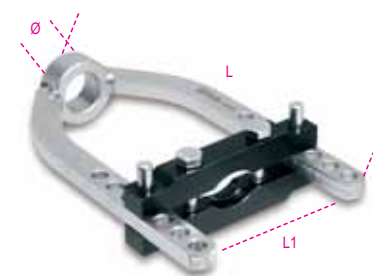

L mm	L1 mm	Ø mm		
250	100	29,5	1	015660051

1568/C13

kit per smagliatura
e ribaditura catene



Ø mm		
3-4-5 mm	1	015680061

350x170x40 mm - 2,3 kg

1568R/CS3

cacciaspina per smagliacatene



1568R/CS3	1	015680503
-----------	---	-----------

1569/C11

serie di utensili
per inserimento cuscinetti

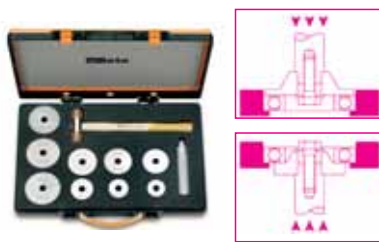

1569/C11 1 015690001

1390 28 mm
Ø 40-45-50-60-63-65-72-76-80 mm
420x280x60 mm - 4,1 kg

1570/1 - 1570/2

martinetti idraulici



	L mm	D mm	P
1570/1	52÷58	24	8t
1570/2	75÷87	32	15t

1 015700001
1 015700002

1580/8I

estrattore universale
idraulico a due griffe

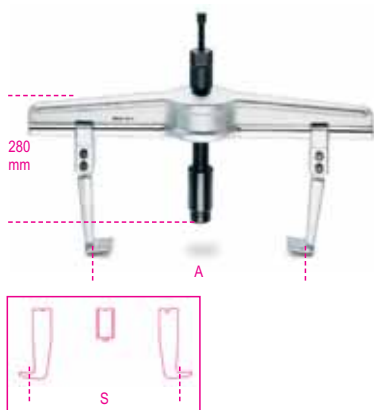

1580/8I 1 015800008

	A mm	S mm
1580/8I	170÷640	260÷715

1585/5I - 6I - 7I

estrattori a tre griffe
per azionamento idraulico

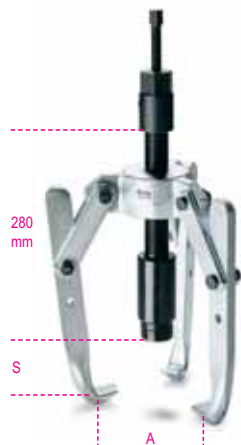

1585/5I 1 015850005
1585/6I 1 015850006
1585/7I 1 015850007

	A mm	S max mm
1585/5I	50÷350	135
1585/6I	50÷350	235
1585/7I	50÷450	335

1585GI/5 - 6 - 7

griffe per estrattori idraulici
1585/5I - 1585/6I - 1585/7I

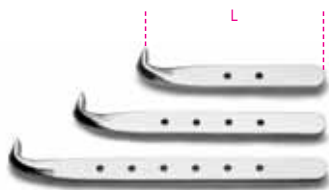

	L mm
1585GI/5	135
1585GI/6	235
1585GI/7	335

1 015850205
1 015850206
1 015850207

1589VI

vite idraulica per estrattori 1580/8I
e 1585/5I - 1585/6I - 1585/7I



1589VI 1 015890001

1589PI/50 - 100 - 150

prolunghe per vite idraulica



	L mm
1589PI/50	50
1589PI/100	100
1589PI/150	150

1 015890005
1 015890010
1 015890015

1590

morsetti standard



A max mm	L1 mm	
60	55	2 015900305
80	65	2 015900307
100	65	2 015900310
120	85	2 015900312
150	95	2 015900315

1591

stretto a vite

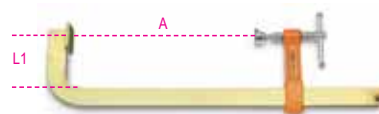

A max mm	L1 mm	
200	80	2 015910020
310	85	2 015910030
410	85	2 015910040
500	95	2 015910050
600	95	2 015910060
800	95	2 015910080
1000	110	2 015910100

1593

serragianti a vite

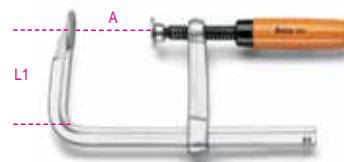

A max mm	L1 mm	
170	80	2 015930016
240	100	2 015930020
320	145	2 015930030
420	145	2 015930040
520	145	2 015930050
610	145	2 015930060

1594

serragianti a leva

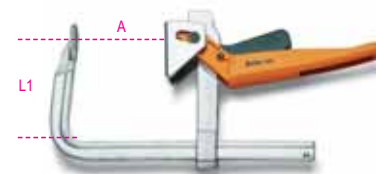

A max mm	L1 mm	
240	145	2 015940020
290	145	2 015940025
340	145	2 015940030
430	150	2 015940040
530	150	2 015940050
630	150	2 015940060

1594A

serragianti in alluminio



A max mm	L1 mm		
100	80	1	015940110
200	80	1	015940125
300	80	1	015940130

1594A/RG

gommino per serragianti 1594A



1594A/RG	2	015940199
----------	---	-----------

1595

serragianti a vite

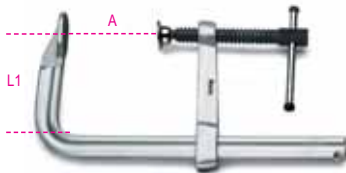

A max mm	L1 mm		
230	100	2	015950020
270	120	2	015950025
330	120	2	015950030
420	120	2	015950040
520	125	2	015950050
620	125	2	015950060
820	125	1	015950080
1030	125	1	015950100

1596

morsetti reversibili in nylon / fibra di vetro



A max mm	L1 mm		
150	60	1	015960115
300	60	1	015960130
450	60	1	015960145

1596/RG

coppia di gommini per morsetti 1596



1596 /RG	1	015960199
----------	---	-----------

1599M

morse parallele da banco forgiate



	A mm		
M100	100	1	015990281
M125	125	1	015990301
M150	150	1	015990302
M165	165	1	015990303

1601/PC

pinza a cricchetto per capicorda telefonia e trasmissione dati

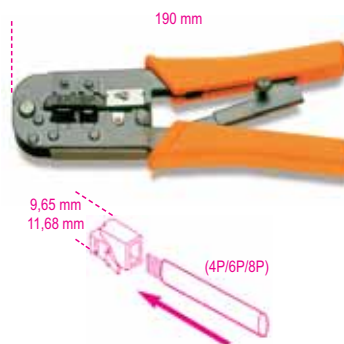

RJ11-RJ12-RJ45	2	016010011
----------------	---	-----------

1602

pinza per capicorda preisolati modello leggero



mm ²		
0,75+6	5	016020001

1602/C9T

pinza per capicorda 1602 con assortimento di 450 capicorda



1602/C9T	1	016020013
----------	---	-----------

1602		n.
1620	R/6,3	1
1620	B/6,3	50
1620	G/6,3	50
1624	R/6,3	50
1624	B/6,3	50
1624	G/6,3	50
1628	R/1,6	50
1628	B/2,3	50
1628	G/3,6	50

420x350x35 mm - 1,5 kg

1602A

pinza per capicorda preisolati modello standard

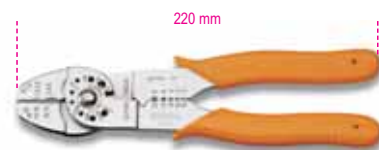

mm ²		
0÷8	2	016020005

1603

pinza per capicorda non isolati modello leggero

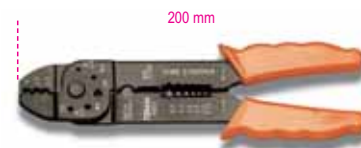

mm ²		
1,25+5,5	5	016030001

1603A

pinza per capicorda non isolati chiusi modello standard

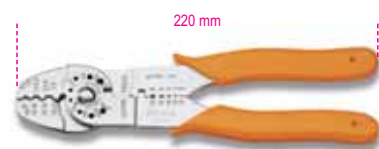

mm ²		
0÷8	2	016030005



1603B

pinza per capicorda non isolati aperti
modello standard



mm²
0+8 2 016030010

1606

pinza a grande effetto
per capicorda cilindrici

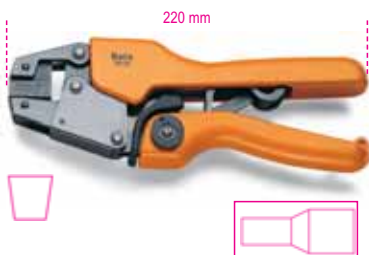

mm²
0,5+6 1 016060001

1608/C9T

pinza per capicorda 1608
con assortimento di 450 capicorda



1 016080013

1604

pinza autobloccante
per capicorda preisolati



mm²
0,5+6 1 016040001

1607

pinza a grande effetto per connettori BNC
per cavi coassiali RG 58, RG 59, RG 62,
RG 71



1607 1 016070001

1608/C9T

1608		n.
1620	R/6,3	50
1620	B/6,3	50
1620	G/6,3	50
1624	R/6,3	50
1624	B/6,3	50
1624	G/6,3	50
1628	R/1,6	50
1628	B/2,3	50
1628	G/3,6	50

420x350x35 mm - 2 kg

1604/C9T

pinza per capicorda 1604
con assortimento di 450 capicorda



1604/C9T 1 016040013

1604		n.
1620	R/6,3	50
1620	B/6,3	50
1620	G/6,3	50
1624	R/6,3	50
1624	B/6,3	50
1624	G/6,3	50
1628	R/1,6	50
1628	B/2,3	50
1628	G/3,6	50

420x350x35 mm - 2 kg

1608

pinza per capicorda preisolati,
con regolatore di pressione



mm²
0,5+6 1 016080001

1608A

pinza a grande effetto
per capicorda preisolati



mm²
0,75+6 1 016080005

1605

pinza autobloccante
per capicorda non isolati



mm²
0,5+6 1 016050001

1609

pinza per capicorda non isolati



mm²
0,5+2,5 1 016090001



1609A

pinza a grande effetto
per capicorda non isolati



mm ²		
0,5+6	1	016090005

1609B

pinza per capicorda non isolati

crimpature a punzone
da 10 mm² a 120 mm²



L mm	mm ²	
600	10÷120	1 016090101

1609C/C5

pinza oleodinamica per capicorda
con 5 coppie di matrici

crimpature esagonali
da 50 mm² a 240 mm²



mm ²		
50÷240	1	016090210

500x300x110 mm - 4 kg

1609M

coppia di matrici per 1609C

crimpature esagonali



	mm ²	
1609M/16	10-16	1 016090221
1609M/35	25-35	1 016090223
1609M/70	50-70	1 016090225
1609M/120	95-120	1 016090227
1609M/150	150	1 016090229
1609M/185	185	1 016090231
1609M/240	240	1 016090233

1610

terminali con attacco tondo



1610R/...K 0,5+1,5 mm² 1610B/...K 1,5+2,5 mm² 1610G/...K 2,5+6 mm²



	D mm	
1610R/4K	4	1 016100104
1610R/5K	5	1 016100105
1610B/5K	5	1 016100115
1610B/6K	6	1 016100116
1610B/8K	8	1 016100118
1610G/6K	6	1 016100126
1610G/8K	8	1 016100128

I prezzi indicati sono relativi a 100 pezzi

1614

spine a punta



1614R/1,9K 0,5+1,5 mm² 1614B/1,9K 1,5+2,5 mm² 1614G/2,8K 2,5+6 mm²



	D mm	
1614R/1,9K	1,9	1 016140101
1614B/1,9K	1,9	1 016140102
1614G/2,8K	2,8	1 016140103

I prezzi indicati sono relativi a 100 pezzi

1616

spine cilindriche maschio



1616R/4K 0,5+1,5 mm²

	D mm	
1616R/4K	4	1 016160104

I prezzi indicati sono relativi a 100 pezzi

1618

spine cilindriche femmina



1618R/4K 0,5+1,5 mm²

	D mm	
1618R/4K	4	1 016180104

I prezzi indicati sono relativi a 100 pezzi

1620

raccordi maschio



1620R/6,3K 0,5+1,5 mm² 1620B/6,3K 1,5+2,5 mm² 1620G/6,3K 2,5+6 mm²

HxS 6,3x0,8 mm HxS 6,3x0,8 mm HxS 6,3x0,8 mm

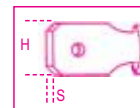

1620R/6,3K	1 016200101
1620B/6,3K	1 016200102
1620G/6,3K	1 016200103

I prezzi indicati sono relativi a 100 pezzi

1622

raccordi femmina



1622R/2,8K 0,5+1,5 mm² 1622B/6,3K 1,5+2,5 mm² 1622G/6,3K 2,5+6 mm²

HxS 2,8x0,5 mm HxS 6,3x0,8 mm HxS 6,3x0,8 mm

1622R/6,3K 0,5+1,5 mm²

HxS 6,3x0,8 mm

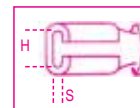

1622R/2,8K	1 016220101
1622R/6,3K	1 016220103
1622B/6,3K	1 016220106
1622G/6,3K	1 016220108

I prezzi indicati sono relativi a 100 pezzi

1624

raccordi femmina isolati



1624R/6,3K 0,5+1,5 mm² 1624B/6,3K 1,5+2,5 mm² 1624G/6,3K 2,5+6 mm²

HxS 6,3x0,8 mm HxS 6,3x0,8 mm HxS 6,3x0,8 mm

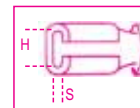

1624R/6,3K	1 016240102
1624B/6,3K	1 016240104
1624G/6,3K	1 016240105

I prezzi indicati sono relativi a 100 pezzi

1628

connettori di linea



1628R/1,6K 0,5+1,5 mm²
 1628B/2,3K 1,5+2,5 mm²
 1628G/3,6K 2,5+6 mm²



	D mm		
1628R/1,6K	1,6	1	016280101
1628B/2,3K	2,3	1	016280102
1628G/3,6K	3,6	1	016280103

I prezzi indicati sono relativi a 100 pezzi

1630

connettori rapidi



1630R/K 0,5+1,5 mm²
 1630B/K 1,5+2,5 mm²

1630R/K	1	016300101
1630B/K	1	016300102

I prezzi indicati sono relativi a 100 pezzi

1632

terminali a tubetto



	mm ²		
1632W/0,5K	0,5	1	016320005
1632G/0,75K	0,75	1	016320007
1632R/1K	1	1	016320010
1632N/1,5K	1,5	1	016320015
1632B/2,5K	2,5	1	016320025
1632G/4K	4	1	016320040
1632Y/6K	6	1	016320060

I prezzi indicati sono relativi a 100 pezzi

1634

terminali doppi a tubetto



	mm ²		
1634W/0,5K	0,5	1	016340005
1634G/0,75K	0,75	1	016340007
1634R/1K	1	1	016340010
1634N/1,5K	1,5	1	016340015
1634B/2,5K	2,5	1	016340025
1634G/4K	4	1	016340040
1634Y/6K	6	1	016340060

I prezzi indicati sono relativi a 100 pezzi

1640K

punzonatrice oleodinamica con 4 fustelle

forature tonde
22,5-25,5-32,5-55,5 mm

1640K 1 016400001

1640

punzonatrice per lamiera



1640 1 016400100

1640A

adattatore per 1640



1640A 1 016400080

1640P

perno filettato per 1640



	Ø mm		
1640P/9	9,5	1	016400088
1640P/19	19	1	016400089

1640Qfustelle quadre per 1640
con perno incluso

1640Q/45 45x45 1 016400065

1640T

fustelle tonde per 1640



	Ø mm		
1640T/22,5	22,5	1	016400022
1640T/25,5	25,5	1	016400025
1640T/32,5	32,5	1	016400032
1640T/55,5	55,5	1	016400055

1650calibro a corsoio
lettura ventesimale

UNI/ISO 3599 DIN 862

1650 1 016500001

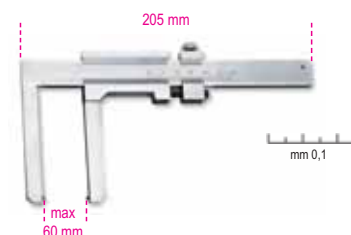
1650FDcalibro a corsoio per dischi freni
lettura decimale

1650FD 1 016500050

1650FTcalibro a corsoio per tamburi freni
lettura ventesimale

	A max mm	L mm		
1650FT	350	438	1	016500060
1650FT/2	500	550	1	016500070

1651DGT

calibro digitale a corsoio
lettura centesimale

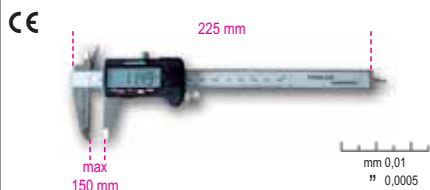

DIN 862

1651DGT 1 016510111

1652

calibro a corsoio con comparatore
lettura cinquantiesimale



DIN 862

1652 1 016520016

1654

calibri a corsoio
lettura cinquantiesimale



UNI/ISO 6906 DIN 862

A max mm	L mm	
200	330	1 016540020
300	410	1 016540030

1654DGT

calibro digitale a corsoio
lettura centesimale

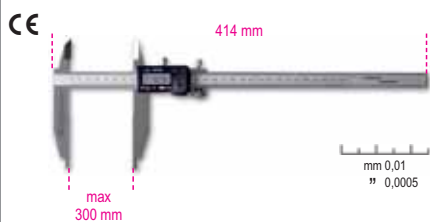

DIN 862

1654DGT 1 016540111

1656

calibri a corsoio di profondità
lettura cinquantiesimale



DIN 862

A max mm	L mm	
200	260	1 016560020
300	360	1 016560030

1657DGT/2

calibro a corsoio di profondità digitale
lettura centesimale

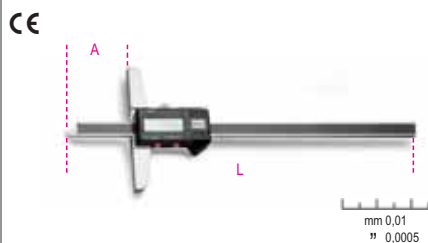

DIN 862

A max mm	L mm	
1657DGT/2 200	270	1 016570002

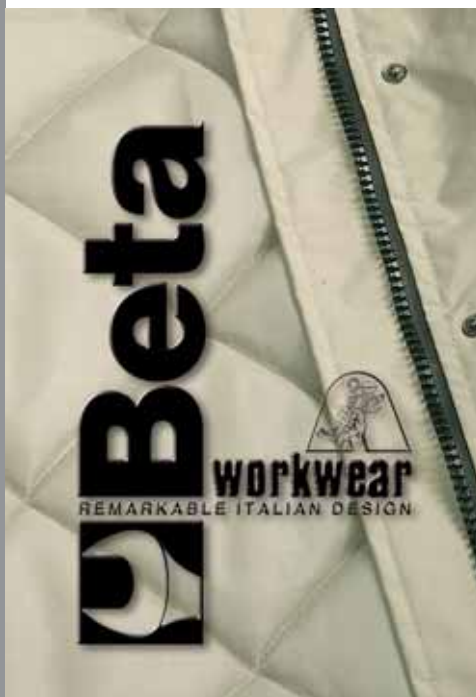

1658/...

micrometri per esterni
lettura centesimale



DIN 863/II

	A mm	
1658/25	0÷25	1 016580025
1658/50	25÷50	1 016580050
1658/75	50÷75	1 016580075
1658/100	75÷100	1 016580100

1658/C4

assortimento di 4 micrometri 1658



1658/C4 1 016580001

1658/25	0÷25 mm
1658/50	25÷50 mm
1658/75	50÷75 mm
1658/100	75÷100 mm

≡ 365x245x35 mm - 2,5 kg

1658DGT

micrometri digitali per esterni
lettura millesimale



DIN 863

	A mm	
1658DGT/25	0÷25	1 016580325
1658DGT/50	25÷50	1 016580350

1658SP/1

supporto per micrometro
in ghisa



1658SP/1 1 016580910

1659

misuratore di spessore
con comparatore
lettura centesimale
C = Campo di comparazione



C	mm	1	016590001
1659	0÷10		

1662/1 - 1662/2

comparatori
lettura centesimale
C = Campo di comparazione



C	mm	1	016620001
1662/1	0÷5		
1662/2	0÷10		

1662DGT

comparatore digitale
lettura centesimale
C = Campo di comparazione



C	mm	1	016620310
1662DGT	0÷12,5		

1662AN

comparatore a tastatore orientabile
lettura centesimale
C = Campo di comparazione



C	mm	1	016620200
1662AN	0÷0,8		

1662SP0

supporto a base magnetica



1662SP0	1	016620800
---------	---	-----------

1662SP2

supporto a base magnetica
snodato



1662SP2	1	016620910
---------	---	-----------

1666A

squadre a cappello
in acciaio inossidabile
rettificate e lappate



L	mm	L1	mm	1	016660110
100		70			
150		100			
200		130			
250		170			
300		200			

1668A

squadre a cappello
in acciaio normalizzato
rettificate



DIN 875/2			
L	mm	L1	mm
100		70	2 016680110
150		100	2 016680115
200		130	2 016680120
250		165	1 016680125
300		176	1 016680130

1670

squadre semplici
in acciaio, rettificate



L	mm	L1	mm		
100		70		3	016700010
150		100		3	016700015
200		130		3	016700020
250		160		3	016700025
300		180		3	016700030
400		200		2	016700040
500		250		2	016700050
600		300		2	016700060
750		375		1	016700080
1000		500		1	016700099

1670A

squadre a cappello
in acciaio, rettificate



L	mm	L1	mm		
100		70		3	016700110
150		100		3	016700115
200		130		3	016700120
250		160		3	016700125
300		180		3	016700130
400		200		2	016700140
500		250		2	016700150
600		300		2	016700160
800		400		1	016700180
1000		500		1	016700199

1672

squadra falsa
a lama orientabile e scorrevole
lama e base in acciaio

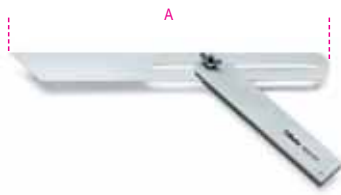

A mm		
300	2	016720030

1672A

squadra falsa
a lama orientabile e scorrevole
lama in acciaio cromata
base in alluminio

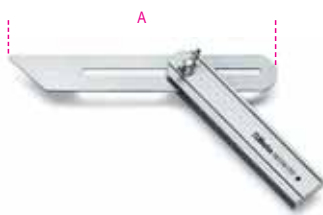

A mm		
200	3	016720120
300	3	016720130

1674A

squadre per falegnami
lama in acciaio, base in alluminio
doppia scala millimetrata



L mm	L1 mm		
300	169	2	016740130
400	214	2	016740140

1676

goniometri semplici
in acciaio

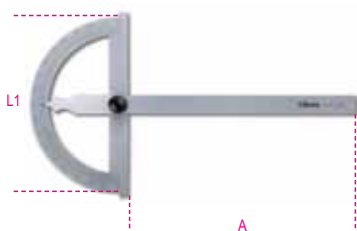

A ~	A mm	L1 mm		
120	120	80	2	016760012
150	165	120	2	016760015
200	210	150	2	016760020
300	310	200	1	016760030

1678/C3

rapportatore d'angoli
in acciaio inossidabile



1678/C3		
	1	016780030

1679

calibro a tracciare con rotella
in acciaio inossidabile
lettura decimale

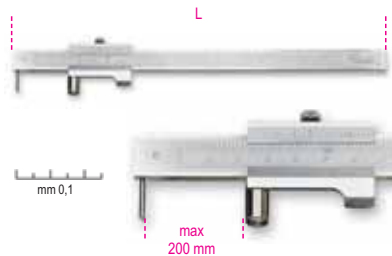

L mm		
265	1	016790020

1680

compasso a verga
corpo e punte di tracciatura
in acciaio temprato

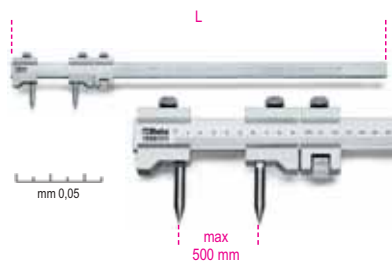

L mm		
612	1	016800050

1680A

compassi di precisione per interni



L mm	A mm		
150	144	2	016800115
200	200	2	016800120
250	245	1	016800125
300	300	1	016800130

1680B

compassi di precisione per esterni



L mm	A mm		
150	155	2	016800215
200	190	2	016800220
250	235	1	016800225
300	280	1	016800230

1680C

compassi di precisione per tracciatori
punte diritte in acciaio temprato



L mm	A mm		
150	138	2	016800315
200	190	2	016800320
250	235	1	016800325
300	280	1	016800330

1682

righe flessibili graduate
in acciaio inossidabile



L mm		
150	5	016820015
200	5	016820020
250	5	016820025
300	5	016820030
500	2	016820050
1000	2	016820100

1683

righe semirigide graduate
in acciaio inossidabile

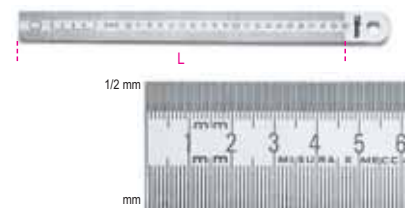

L mm		
300	5	016830030
500	2	016830050
1000	2	016830100
1500	1	016830150
2000	1	016830200

1685/C7

assortimento di 7 strumenti per misurare e tracciare



1685/C7 1 016850110

	1650	160 mm
	1658/25	0+25 mm
	1670	100 mm
	1680C	150 mm
	1682	150 mm
	1688BC	165 mm
	1688BC/R	

320x210x37 mm - 1,2 kg

1687A

punta di precisione piegata a 90° con impugnatura

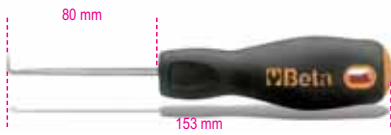

1687A 1 016870120

1687AC

punta di precisione piegata corta con impugnatura

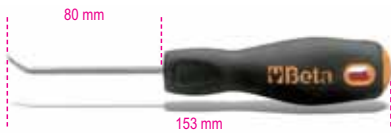

1687AC 1 016870125

1687D

punta di precisione diritta con impugnatura



1687D 1 016870110

1687U

punta di precisione ad uncino con impugnatura

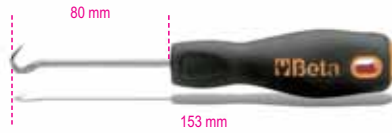

1687U 1 016870115

1687/S4

serie di 4 punte di precisione con impugnatura



1687/S4
1687A-1687AC
1687D-1687U 1 016870150

1688

punta per tracciare in acciaio temprato



1688 5 016880020

1688A

punta per tracciare in acciaio temprato con punte in carburo di tungsteno



1688A 5 016880120

1688BC

punta per tracciare a penna in acciaio temprato cromato

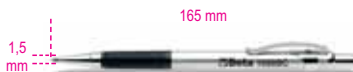

1688BC 1 016880200

1688BC/R

punta di ricambio per 1688BC



1688BC/R 1 016880210

1688M

matita per falegnami



1688M 50 016880880

1690F

metro pieghevole in fibra di vetro classe di precisione III



	L m	S mm	
1690F/2	2	17	5 016900220

1690L

metro pieghevole in legno di betulla classe di precisione III



	L m	S mm	
1690L/2	2	17	5 016900200

1691/...

flessometri
cassa in ABS antiurto
nastro in acciaio
classe di precisione II



	L m	S mm	
1691/3	3	19	5 016910003
1691/5	5	25	5 016910005
1691/8	8	25	5 016910008
1691/10	10	25	5 016910010

1691A

flessometro
cassa in ABS antiurto
nastro rivestito in Nylon
classe di precisione II



	L m	S mm	
1691A/5	5	19	5 016910055
1691A/8	8	25	5 016910058

1692B/...

flessometri
cassa in ABS antiurto
nastro in acciaio
classe di precisione II



	L m	S mm		
1692B/2	2	13	5	016920022
1692B/3	3	13	5	016920023
1692B/5	5	19	5	016920025

1694/L

rotelle metriche
cassa in ABS antiurto
nastro in fibra di vetro ricoperto in PVC
classe di precisione III

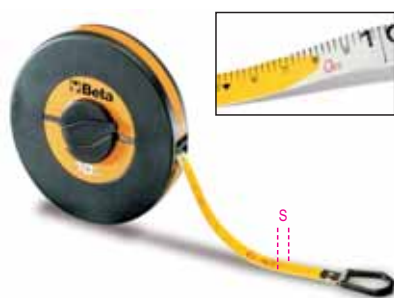

	L m	S mm		
1694/L10	10	13	1	016940110
1694/L20	20	13	1	016940120

1694A/L

rotelle metriche con impugnatura
cassa in ABS antiurto
nastro in fibra di vetro ricoperto in PVC
classe di precisione III



	L m	S mm		
1694A/L30	30	13	1	016940230
1694A/L50	50	13	1	016940250

1694B/L

rotella metrica con impugnatura
cassa in alluminio
nastro in acciaio smaltato
classe di precisione II



	L m	S mm		
1694B/L	50	12,5	1	016940350

1696

livelle in alluminio profilato anodizzato
con file infrangibili
precisione 1 mm/m



L mm		
200	2	016960002
400	2	016960004
500	2	016960005
600	2	016960006
800	2	016960008
1000	2	016960010

1696A

livelle in alluminio pressofuso
con 1 base rettificata a 2 file infrangibili
precisione 1 mm/m



L mm		
300	2	016960103
400	2	016960104
500	2	016960105
600	2	016960106
800	2	016960108
1000	2	016960110

1696B

livelle con base magnetica
in alluminio profilato
anodizzato a 2 file infrangibili
precisione 1 mm/m



L mm		
300	2	016960203
400	2	016960204
500	2	016960205
600	2	016960206

1696C

livelle in alluminio pressofuso
con 4 basi rettificcate
a 3 file infrangibili
precisione 1 mm/m



L mm		
300	2	016960303
400	2	016960304
500	2	016960305
600	2	016960306

1696S

stadie in alluminio con impugnatura
a due file infrangibili
precisione 1 mm/m



L mm		
1500	1	016960415
2000	1	016960420
2500	1	016960425
3000	1	016960430

1699L

livella lineare di precisione
in ghisa con base prismatica rettificata
a 2 file infrangibili
precisione 0,05 mm/m



L mm		
1699L	1	016990002

1699L/1

livella lineare di precisione
in ghisa con base prismatica rettificata
a 2 file infrangibili
precisione 0,02 mm/m



L mm		
1699L/1	1	016990005



1699Q

livelle quadre di precisione
in ghisa con 2 basi prismatiche
e 2 basi piane rettificate
a 2 file infrangibili
precisione 0,05 mm/m



DIN 877

L mm	A mm		
150	36	1	016990015
200	45	1	016990020

1700N

punte per edilizia



S mm	L mm		
14	250	5	017000004
16	300	5	017000006

1700N/PM

punte per edilizia
con paramano



S mm	L mm		
14	250	2	017000104
16	300	2	017000106

1701N

scalpelli per edilizia



L mm	A mm	S mm		
250	20	14	5	017010002
300	23	16	5	017010003

1701N/PM

scalpelli per edilizia
con paramano



L mm	A mm	S mm		
250	20	14	2	017010102
300	23	16	2	017010103

1701PMR

paramano per 1700N e 1701N

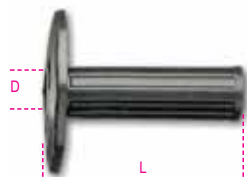

D mm	L mm		
14	115	1	017010200
16	115	1	017010206

1701NE/...

scalpelli per elettricisti



	SxL mm		
1701NE/3	10x200	5	017010406
1701NE/4	10x250	5	017010409

1702N

scalpelli a tagliente extrapiatto



A mm	SxH mm		
50	12x25	2	017020005
70	12x25	2	017020007

1702N/PM

scalpelli a tagliente extrapiatto
con paramano

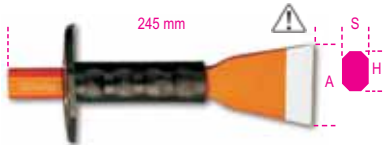

A mm	SxH mm		
50	12x25	2	017020105
70	12x25	2	017020107



Si raccomanda di raffreddare
frequentemente l'utensile durante
la riaffilatura.

1702PMR

paramano per 1702N



L mm			
115	1	017020200	

1704

leve piegate per carpentieri



L mm			
500	2	017040050	
600	2	017040060	
800	2	017040080	

1704A

leve con estremità a punta
e a scalpello

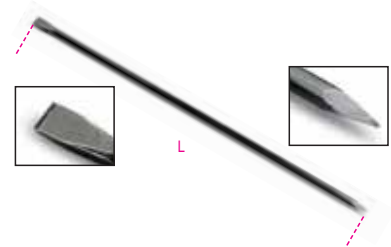

L mm			
1500	1	017040110	
2000	1	017040120	

1704C

leve con estremità a punta
e penna chiusa

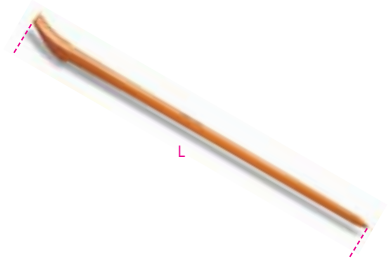

L mm			
1200	1	017040210	
1400	1	017040212	
1600	1	017040215	

1705

traccialinea
in alluminio

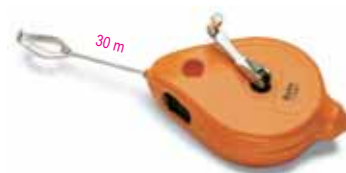

1705	4	017050001	

1705PT

polvere traccialinea



g
250

5 017050025

1706DGT

calibro digitale di profondità
per battistrada pneumatici



1706DGT

1 017060011

1707

contafilette

Per filetti metrici ISO a 60° e Whitworth a 55°



P (ISO)
0,25+6

W
62+4x1"

5 017070001

1707A/1 - 2 - 3

raggimetri

lame concave e convesse, in acciaio



	R mm	
1707A/1	1,0÷7,0	2 017070007
1707A/2	7,5÷15	2 017070015
1707A/3	15,5÷25	2 017070025

1708/8 - 13 - 20

spessimetri



1708/8	S = 0,05+0,50 mm	5 017080008
1708/13	S = 0,05+1,00 mm	5 017080013
1708/20	S = 0,05+1,00 mm	5 017080020

1709/10 - 1709/18

spaccadadi



	L mm	A max mm	
1709/10	90	17 (M10)	1 017090010
1709/18	108	25 (M16)	1 017090018

1710

spaccadadi idraulico



A min mm	A max mm	
7(M4)	22(M14)	1 017100001

1712E/1 - 2 - 3

flessibili magnetici

F = forza magnetica



	L mm	D mm	F kg	
1712E/1	420	7,5	0,5	5 017120011
1712E/2	530	15	1,8	5 017120012
1712E/3	532	19	3,0	5 017120013

1712E/L1

flessibile magnetico
con illuminazione LED

F = forza magnetica

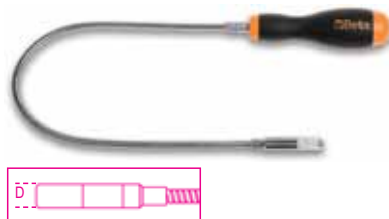

	L mm	D mm	F kg	
1712E/L1	500	6,5	0,75	3 017120111

1713M

artigli prensili flessibili

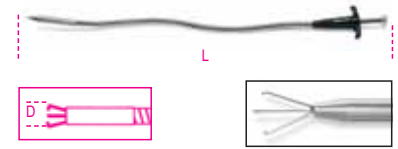

L mm	D mm	
500	7	2 017130011
1000	7	1 017130015

1714

specchietto rigido
in materiale plastico



1714 5 017140001

1715

specchietto telescopico articolato
corpo in metallo cromato



1715 1 017150001

1715FL/A

specchietto flessibile rettangolare



1715FL/A 1 017150110

1715FL/B

specchietto flessibile rettangolare
con illuminazione

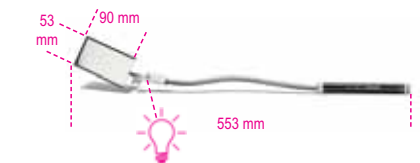

1715FL/B 1 017150115

1716R

punteruolo a punta tonda



1716R 5 017160001

Beta
Collection

1716Q

punteruolo a punta quadra



1716Q 5 017160010

1716A

punta angolata per usi generici

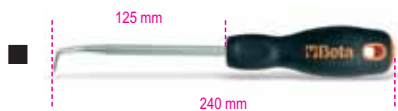

1716A 3 017160040

1716P

raschietto per guarnizioni

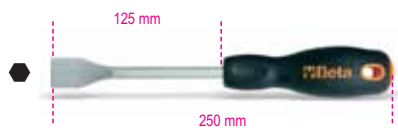

1716P 3 017160020

1716U

punta ad uncino per usi generici



1716U 3 017160025

1717A

raschietti a due taglienti



L mm	L1 mm	
150	70	5 017170015
200	75	5 017170020
250	100	5 017170025

1717B

raschietti a tre taglienti



L mm	L1 mm	
150	75	5 017170115
200	85	5 017170120
250	100	5 017170125

1717C

raschietti piatti



L mm	S mm	
150	18	5 017170215
200	20	5 017170220
250	25	5 017170225

1717D

raschietto piatto a tagliente frontale



1717D 5 017170320

1718A6/...

lime a taglio mezzodolce 6" senza impugnatura

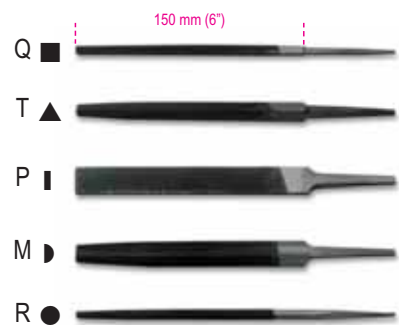

1718A6/Q	5 017180021
1718A6/T	5 017180023
1718A6/P	5 017180025
1718A6/M	5 017180027
1718A6/R	5 017180029

1718A8/...

lime a taglio mezzodolce 8" senza impugnatura

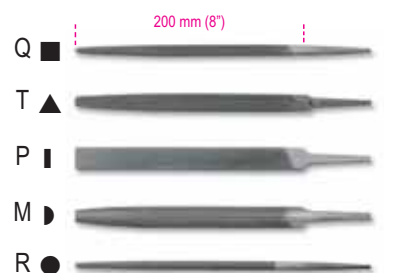

1718A8/Q	5 017180031
1718A8/T	5 017180033
1718A8/P	5 017180035
1718A8/M	5 017180037
1718A8/R	5 017180039

1718A8/S5 1 017180040

1718A10/...

lime a taglio mezzodolce 10" senza impugnatura

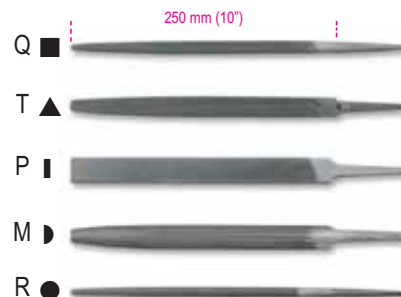

1718A10/Q	5 017180041
1718A10/T	5 017180043
1718A10/P	5 017180045
1718A10/M	5 017180047
1718A10/R	5 017180049

1718A10/S5 1 017180050

1718D6/...

lime a taglio bastardo 6" senza impugnatura

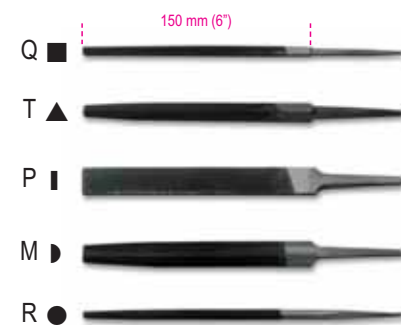

1718D6/Q	5 017180121
1718D6/T	5 017180123
1718D6/P	5 017180125
1718D6/M	5 017180127
1718D6/R	5 017180129

1718D6/S5 1 017180130

1718D8/...

lime a taglio bastardo 8"
senza impugnatura

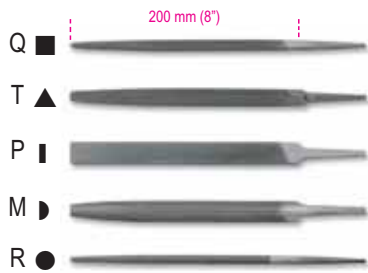

1718D8/Q	5	017180131
1718D8/T	5	017180133
1718D8/P	5	017180135
1718D8/M	5	017180137
1718D8/R	5	017180139

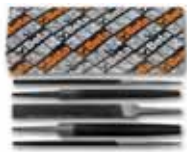

1718D8/S5 1 017180140

1718D10/...

lime a taglio bastardo 10"
senza impugnatura



1718D10/Q	5	017180141
1718D10/T	5	017180143
1718D10/P	5	017180145
1718D10/M	5	017180147
1718D10/R	5	017180149

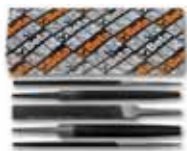

1718D10/S5 1 017180150

1719BMA

lime a taglio mezzodolce 8"
impugnatura in materiale plastico

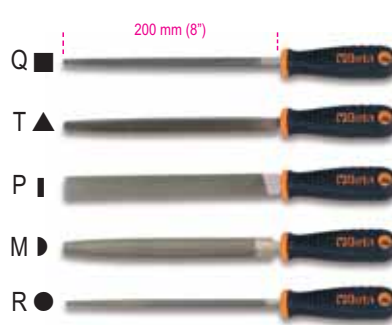

1719BMA/Q	5	017190052
1719BMA/T	5	017190054
1719BMA/P	5	017190056
1719BMA/M	5	017190058
1719BMA/R	5	017190060



1719BMA/S5 1 017190070

1719BMB/P

lime piatte a taglio universale
impugnatura in materiale plastico



1719BMB/P250	5	017190152
1719BMB/P300	5	017190153

1719BMC

lime mezzotonde e piatte a mazzo
impugnatura in materiale plastico



1719BMC/M250	6	017190252
1719BMC/M300	4	017190253
1719BMC/P250	6	017190262
1719BMC/P300	4	017190263

1719BMD8

lime a taglio bastardo 8"
impugnatura in materiale plastico



1719BMD8/Q	5	017190221
1719BMD8/T	5	017190223
1719BMD8/P	5	017190225
1719BMD8/M	5	017190227
1719BMD8/R	5	017190229

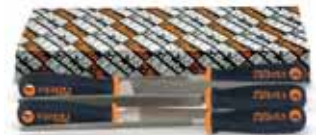

1719BMD8/S5 1 017190230

1719BM/RR

raspa tonda
impugnatura in materiale plastico



1719BM/RR	5	017190351
-----------	---	-----------

1719BM/RL

lima raspa piatta
impugnatura in materiale plastico



1719BM/RL	5	017190360
-----------	---	-----------

1719BMR

impugnature per lime



	L mm	A mm	
1719BMR/0	95	25	10 017190950
1719BMR/1	110	29	10 017190951
1719BMR/1B	110	29	10 017190953
1719BMR/2	123	31	10 017190952

	mm		
1719BMR/0	100/150	4/6	▲ ▽ ●
1719BMR/1	150/200	6/8	▲ ▽ ●
1719BMR/1B	150/200	6/8	▲ ▽ ●
1719BMR/2	250/300	10/12	▲ ▽ ●



1720/...

lime ad ago

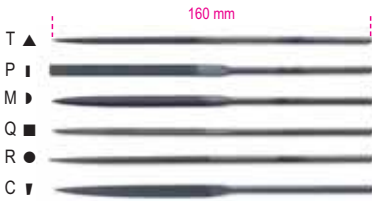

1720T	5	017200004
1720P	5	017200006
1720M	5	017200008
1720Q	5	017200009
1720R	5	017200010
1720C	5	017200012



1720/S3	1	017200000
---------	---	-----------



1720/B6	1	017200002
---------	---	-----------

1720D/...

lime ad ago diamantate

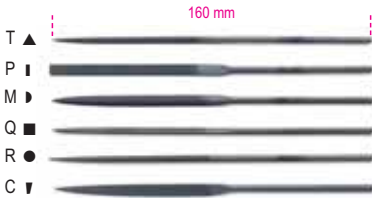

1720D/T	2	017200104
1720D/P	2	017200106
1720D/M	2	017200108
1720D/Q	2	017200109
1720D/R	2	017200110
1720D/C	2	017200112



1720D/B6	1	017200120
----------	---	-----------

1721/B6

serie di 6 lime per contatti
in busta di plastica



1721/B6	1	017210010
---------	---	-----------

1723

tenditore per molle



1723	5	017230001
------	---	-----------

1725

seghetto



1725	4	017250001
------	---	-----------

1725CR

miniseghetto



1725CR	5	017250010
--------	---	-----------

1725MQ

miniseghetto



EN 60900		
1725MQ	2	017250030

1726

seghetto
sistema di tensionamento della lama
incorporato nell'impugnatura

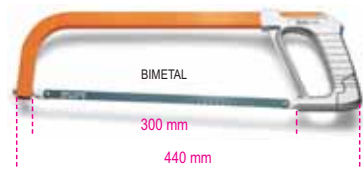

1726	4	017260001
------	---	-----------

1726BM

seghetto con sistema di tensionamento
della lama a sgancio rapido



1726BM	2	017260050
--------	---	-----------

1727

seghetto tipo pesante



1727	4	017270001
------	---	-----------

1727M

seghetto
mono-impugnatura



1727M	5	017270010
-------	---	-----------

1728...

lame per seghetti



1728LA	100	017280001
1725CR		
1725MQ		
1728BM	100	017280010
1725-1726		
1727-1727M		
1728CO	100	017280030
1725-1726		
1727-1727M		

1729

segoncino ad arco

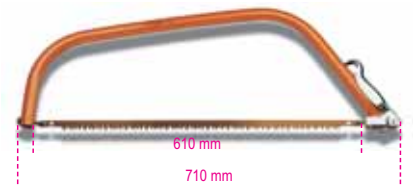

1729	5	017290001
------	---	-----------

1729LR

lama per segoncino 1729



1729LR	10	017290010
--------	----	-----------

1736A

spazzola per lime



240 mm

1736A 10 017360010

1737

spazzolino con fili di ottone



145 mm

1737 10 017370001

1737NX

spazzola curva a fili di acciaio



270 mm

1737NX 5 017370010

1737AC

spazzola a fili di acciaio



275 mm

1737AC 5 017370020

1737B

coppie di spazzole per pulizia morsetti e poli batteria veicoli



1737B 1 017370050

1738

pennello



30 mm

210 mm

1738 10 017380001

1739A

rivettatrice estensibile fornita con 5 testine intercambiabili



max 830 mm

Ø mm	3,2	4	4,8	5	6	6,4
Alluminio	•	•	•	•	•	•
Inox	•	•	•	•		

1739A 1 017390101

1740A

rivettatrice di potenza fornita con 5 testine intercambiabili



525 mm

Ø mm	3,2	4	4,8	5	6	6,4
Alluminio	•	•	•	•	•	•
Inox	•	•	•	•		

1740A 1 017400101

1741

rivettatrice fornita con 4 testine intercambiabili



250 mm

Ø mm	2,4	3	3,2	4	4,8
Alluminio	•	•	•	•	•
Acciaio	•	•	•	•	

1741 1 017410001

1741A

rivettatrice fornita con 4 testine intercambiabili



250 mm

Ø mm	2,4	3	3,2	4	4,8	5
Alluminio	•	•	•	•	•	•
Acciaio	•	•	•	•		
Inox	•	•	•	•		

1741A 1 017410300

1741RV...K

rivetti in alluminio

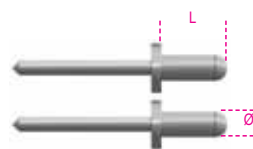

1741RV2,9K 1 017410191

ØxL = 3x6 mm

1741RV3,2K 1 017410192

ØxL = 3,2x8 mm

1741RV3,8K 1 017410193

ØxL = 4x10 mm

1741RV4K 1 017410194

ØxL = 4x12 mm

1741RV4,8K 1 017410195

ØxL = 4,8x12 mm

I prezzi indicati sono relativi a 500 pezzi

1741/C5

rivettatrice 1741 con assortimento di 700 rivetti in alluminio



1741/C5 1 017410005

	Ø mm	L mm	n.
1741RV2,9K	3,0	6	200
1741RV3,2K	3,2	8	200
1741RV3,8K	4,0	10	100
1741RV4K	4,0	12	100
1741RV4,8K	4,8	12	100

420x160x60 mm - 3150 g

1742

rivettatrice per inserti filettati
fornita con 4 testine intercambiabili



1742 1 017420001

M	Ø mm	L mm
3	5	11
4	6	11
5	7	13
6	9	17

1742KR

kit di 4 perni di ricambio per 1742



1742KR 1 017420011

1742R-A/M...

rivetti in acciaio filettati per 1742-1742A



1742R-A/M3 1 017420013

ØxL = 5x11 mm
M = 3

1742R-A/M4 1 017420014

ØxL = 6x11 mm
M = 4

1742R-A/M5 1 017420015

ØxL = 7x13 mm
M = 5

1742R-A/M6 1 017420016

ØxL = 9x17 mm
M = 6

1742R-A/M8 1 017420018

ØxL = 11x17 mm
M = 8

1742R-A/M10 1 017420020

ØxL = 13x24 mm
M = 10

I prezzi indicati sono relativi a 20 pezzi

• I prezzi indicati sono relativi a 10 pezzi

1742R-AL/M...

rivetti in alluminio filettati per 1742-1742A



1742R-AL/M3 1 017420023

ØxL = 5x10 mm
M = 3

1742R-AL/M4 1 017420024

ØxL = 6x12 mm
M = 4

1742R-AL/M5 1 017420025

ØxL = 7x13 mm
M = 5

1742R-AL/M6 1 017420026

ØxL = 9x15 mm
M = 6

I prezzi indicati sono relativi a 20 pezzi

1742/C4

rivettatrice 1742 con assortimento
di 400 inserti filettati in acciaio



1742/C4 1 017420005

	M	Ø mm	n.
1742R-A/M3	3	5	100
1742R-A/M4	4	6	100
1742R-A/M5	5	7	100
1742R-A/M6	6	9	100

370x310x80 mm - 2,9 kg

1742A

rivettatrice di potenza per inserti filettati
fornita con 4 testine intercambiabili



1742A 1 017420100

M	Ø mm	L mm
5	7	13
6	9	17
8	11	17
10	13	24

1742A/KR

kit di 4 perni di ricambio per 1742A

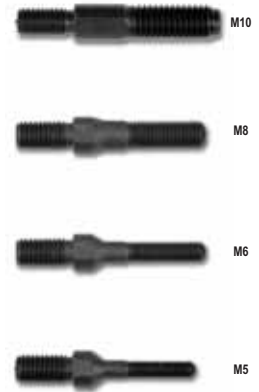

1742A/KR 1 017420111

1742A/C

rivettatrice 1742A con assortimento
di 60 inserti filettati in acciaio



1742A/C 1 017420105

	M	Ø mm	n.
1742R-A/M5	5	7	20
1742R-A/M6	6	9	20
1742R-A/M8	8	11	10
1742R-A/M10	10	13	10

536x310x80 mm - 2,1 kg

1743

pinza per fascette in Nylon

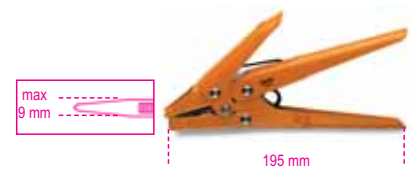

1743 3 017430001

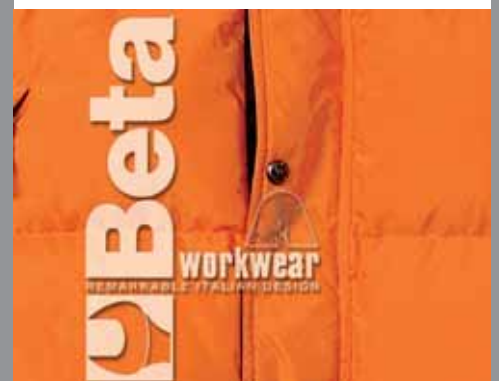

1748/...K

fascette in Nylon
a testa autobloccante

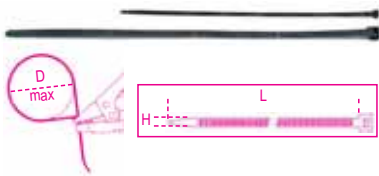

1748/3K	HxL = 2,5x100 mm D = 18 mm	1	017480203
1748/6K	HxL = 2,5x160 mm D = 40 mm	1	017480206
1748/7K	HxL = 3,6x150 mm D = 33 mm	1	017480207
1748/8K	HxL = 3,6x200 mm D = 46 mm	1	017480208
1748/9K	HxL = 3,6x300 mm D = 70 mm	1	017480209
1748/14K	HxL = 4,8x190 mm D = 43 mm	1	017480214
1748/17K	HxL = 4,8x300 mm D = 72 mm	1	017480217
1748/18K	HxL = 4,8x360 mm D = 85 mm	1	017480218
1748/23K	HxL = 7,6x300 mm D = 67 mm	1	017480223
1748/24K	HxL = 7,6x368 mm D = 88 mm	1	017480224
1748/26K	HxL = 8x430 mm D = 120 mm	1	017480226

I prezzi indicati sono relativi a 100 pezzi

1748B/...K

fascette in Nylon, a testa autobloccante
bianche

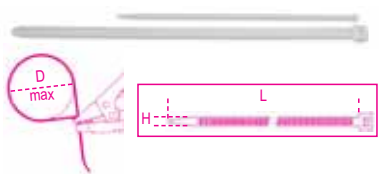

1748B/3K	HxL = 2,5x100 mm D = 18 mm	1	017480303
1748B/6K	HxL = 2,5x160 mm D = 40 mm	1	017480306
1748B/7K	HxL = 3,6x150 mm D = 38 mm	1	017480307
1748B/8K	HxL = 3,6x200 mm D = 46 mm	1	017480308
1748B/9K	HxL = 3,6x300 mm D = 70 mm	1	017480309
1748B/14K	HxL = 4,8x190 mm D = 44 mm	1	017480314
1748B/17K	HxL = 4,8x300 mm D = 72 mm	1	017480317
1748B/18K	HxL = 4,8x360 mm D = 86 mm	1	017480318

I prezzi indicati sono relativi a 100 pezzi

1748/C5

pinza per fascette
con assortimento di 400 fascette



1748/C5 1 017480100

	H mm	L mm	n.
1743			1
1748/2K	2,4	80	100
1748/7K	3,6	140	100
1748/8K	3,6	200	100
1748/14K	4,8	190	100

325x245x55 mm - 850 g

1749

pistola per sigillante
in lamiera verniciata



1749 2 017490001

1749A

pistola per sigillante
modello professionale
tubo in alluminio.

Anche per sacchetti



1749A 1 017490010

1750B

compressori a leva per grasso



cc	L mm		
500	380	1	017500205
1000	600	1	017500210

1750R/1 - 1750R/2

tubi flessibili di ricambio
in Nylon



	L mm		
1750R/1	310	2	017500030
1750R/2	410	2	017500040

1750RC

tubo rigido piegato



1750RC 2 017500050

1750RT

testina a 4 griffe
tipo "Hydraulic"



1750RT 5 017500110

1750RP/1 - 1750RP/2

testine per raccordi piatti

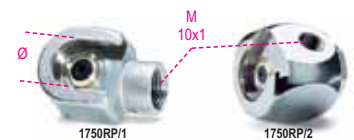

	Ø mm		
1750RP/1	16	2	017500115
1750RP/2	22	2	017500120

1750CG

cartucce di grasso per 1750B



cc			
400		18	017500140
600		18	017500160



1751

oliatori metallici a pressione
cannuccia flessibile



cc	D mm		
200	62	4	017510002
300	75	4	017510003
500	85	4	017510005
750	100	2	017510007
1000	100	2	017510011

1751R

cannuccia di ricambio
per 1751



cc			
200÷1000		5	017510010

1752

oliatori in plastica a pressione
cannuccia rigida



cc	D mm		
200	67	4	017520002
300	77	4	017520003
500	95	4	017520005
700	95	2	017520007

1752R

cannuccia di ricambio
per 1752



cc			
200÷700		5	017520020

1753

oliatori in plastica a pressione
cannuccia flessibile



cc	D mm		
200	65	4	017530002
300	80	4	017530003
500	95	4	017530005
700	95	2	017530007

1753R

cannuccia di ricambio
per 1753



cc			
200÷700		5	017530020

1754

oliatori in plastica a pressione
cannuccia flessibile



cc	D mm		
150	60	5	017540015
250	65	5	017540025

1755

oliatori in plastica
cannuccia rientrante



cc	L mm		
30	160	5	017550003
80	170	5	017550008
150	230	5	017550015

1756

oliatore a stilo



cc			
5		5	017560001

1756B

siringa per olio



cc			
500		2	017560220

1757

rabocatori per liquidi batterie



cc	D mm		
250	60	4	017570002
500	75	4	017570004
1000	90	2	017570006

Beta



1757A

colmatore per liquidi batterie



cc
2000

1 017570020

1758

imbuto



1758

1 017580001

1759A

densimetro per liquido anticongelante



1759A

1 017590001

1759B

densimetro per liquidi batteria



1759B

1 017590005

1759HD/1

strumento per controllo tenuta impianto di raffreddamento



1759HD/1

1 017590052

480x410x110 mm - 3,6 kg

1759M

analizzatore ottico per liquidi di raffreddamento e batteria



- Misurazione istantanea: livello carica batteria e punto di congelamento liquido di raffreddamento da -3 a -48°C.
- Carico del liquido batteria da 1100 g/l a 1400 g/l.
- Fornito con contagocce per il prelievo dei liquidi e astuccio.
- Compensazione automatica delle misure in funzione delle temperature.

1759M

1 017590201

1760DGT

multimetro digitale

**DATI TECNICI**

RPM (tachimetro):
RPM4 600 - 4000 RPM
RPM4 600 - 12000 RPM (x10 RPM)
RPM2/DIS 300 - 4000 RPM
RPM2/DIS 300 - 6000 RPM (x10 RPM)
Angolo Dwell: 4-8 CYL
Tensione DC: 400mV-4/40/400/1000V
Tensione AC: 4/40/400/700V
Corrente DC: 40/400mA-4/20A
Corrente AC: 40/400mA-4/20A
Resistenza: 400Ω-4/40/400kΩ-4/40MΩ
Capacità: 40/400nF-4/40/100μF
Frequenza: 5/50/500Hz-50/500-10MHz
Duty Cycle: 0.1 - 99,9%
Ampiezza pulsazioni: 1 - 10ms
Prova diodi: Corrente test 0,3mA
Continuità: <1500Ω - Corrente test <0,3mA
Display: LCD ad alto contrasto 4 digit retro-illuminato
Sovratensione: Categoria II 1000V
Autospegnimento: 30 minuti
Alimentazione: 1 batteria 9V (inclusa)
Pinza induttiva (inclusa)
2 Puntali (inclusi)
Custodia morbida in tela (inclusa)
Manuale d'uso

1760DGT

1 017600005



1760 400A

pinza amperometrica per multimetri



CE

AC/DC

PARAMETRI RILEVABILI

Corrente max: 400A
Frequenza: 50/60 Hz
Alimentazione: 1 batteria da 9V (inclusa)

1760 400A

1 017600080

1760A

multimetro digitale



CE



PARAMETRI RILEVABILI

Tensione DC: 200 mV-2/20/200/1000V
Tensione AC: 2-20/200/700V
Corrente DC: 2/20/200 mA-10 A
Corrente AC: 2/200 mA-10 A
Resistenza: 200Ω - 2/20/200 kΩ - 2/20 MΩ
Capacità: 2/20/200 nF - 2/20 μF
Temperatura: -20° + 1000°C
Frequenza: 20kHz
Alimentazione: 1 batteria da 9V (inclusa)

1760A

1 017600010

1760PA/AC

pinza amperometrica e multimetro digitale



CE

A: AC
V: AC/DC



PARAMETRI RILEVABILI

Tensione DC: 400 mV - 4/40/400/600 V
Tensione AC: 400 mV - 4/40/400/600 V
Corrente AC: 40/400/1000 A
Resistenza: 400Ω - 4/40/400 kΩ - 4/40 MΩ
Frequenza: 5/50/500 Hz - 5/50/500 kHz - 5/10 MHz
Capacità: 40/400 nF - 4/40/100 μF
Temperatura: -20°C + 1000°C / - 4 °F + 1832 °F
Alimentazione: 1 batteria da 9V (inclusa)

1760PA/AC

1 017600050

1760/TC2

tachimetro digitale a distanza e a contatto



CE

DATI TECNICI

- Per misurazione di:
 - rotazione a distanza (g/min - rpm)
 - rotazione (g/min - rpm)
 - e velocità lineare (m/min o ft/min) a contatto.
- Display LCD a 5 cifre.
- Scala:
 - a distanza 2,5+99.999 g/min
 - a contatto 0,5+19.999 g/min
 - velocità lineare 0,05+1.999,9 m/min.
- Frequenza: 0,8 sec.
- Alimentazione: 4 batterie 1,5V (AA) (incluse) o alimentatore 6V (non incluso)
- Fornito con:
 - adattatore per misurazioni a contatto
 - 2 puntali maschio in gomma
 - 1 puntale femmina in gomma
 - 1 rotella per rilevazioni lineari
 - etichette riflettenti
 - manuale di istruzioni
 - custodia in plastica.

1760/TC2

1 017600161

1760R/TC2

etichette riflettenti per 1760/TC2



1760R/TC2

1 017600561

1760/IR800

termometro digitale ad infrarossi con doppio puntamento laser



CE

DATI TECNICI

Gamma: da -50°C a 800°C / da -58°F a 1472°F
Selezione scala: °C/°F
Precisione: ±1,0% o ±1,0°C a 20°C
Potenza Laser: <1mW
Risposta: 150ms
Emissività: 0,10-1,0 regolabile
Rapporto distanza: (D:S) 20:1
Temperatura operativa: 0°C + 50°C / 32°F + 122°F
Umidità operativa: da 10% a 90% RH
Display LCD retro-illuminato
Funzione di mantenimento dei dati
Auto spegnimento
Alimentazione: 1 batteria 9V (inclusa)
Custodia morbida in tela (inclusa)
Manuale d'uso

1760/IR800

1 017600380

 Beta

1760/IR1600

termometro digitale ad infrarossi
con puntamento laser



CE

DATI TECNICI

Gamma: da -50°C a 1600°C / da -58°F a 2912°F
Selezione scala: °C/°F
Precisione: ±1,5% o ±2°C a 20°C
Potenza Laser: <1mW
Risposta: 1sec
Emissività: 0,10-1,0 regolabile
Rapporto distanza: (D:S) 50:1
Temperatura operativa: 0°C + 50°C / 32°F + 122°F
Umidità operativa: da 10% a 90% RH
Display LCD retro-illuminato
Funzione di mantenimento dei dati
Auto spegnimento
Alimentazione: 1 batteria 9V (inclusa)
Custodia rigida e treppiede in alluminio
Manuale d'uso

1760/IR1600

1 017600460

1760/2TM

termometro digitale a due uscite



CE

- Termometro a termocoppia di tipo K a due ingressi
- Display LCD 42 mm con indicatore di funzione, retro-illuminato.
- Lettura massima di 1999
- Misurazioni in gradi Celsius (°C) o Fahrenheit (°F) selezionabili
- Gamma: da -50 °C a 1300 °C / da -58 °F a 2372 °F
- Risoluzione: 1 °C o 1 °F - 0,1 °C o 0,1 °F
- Precisione dello 0,5% del massimo valore e di ritenuta dati
- Dotazione: 2 sensori a termocoppia di tipo K
- Custodia morbida in tela
- 1 batteria 9V inclusa
- Manuale d'uso

1760/2TM

1 017600100

1761

pinza torcifilo
a ritorno automatico

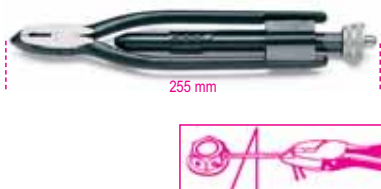

1761

1 017610001

1761RS/1

pinza torcifilo reversibile
a ritorno automatico

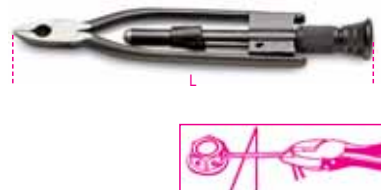

1761RS/1

L
~
220

1 017610030

1762

pinza fustellatrice



∅
mm
2-2,5-3
3,5-4-4,5

2 017620001

1765/C24

cassetta di 24 attrezzi
per estrazione autoradio



1765/C24

1 017650001

1766

ventosa doppia

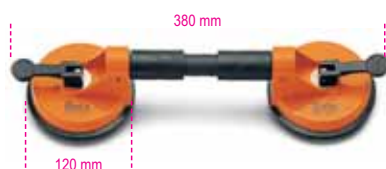

max
kg
50

1369A/8

2 017660001

1766A

ventosa singola



max
kg
30

2 017660005

1766CN

cinghia con tenditore
a cricchetto



4 m

2 017660010

1766L

leva per cristalli



1766L

1 017660015

1766I

impugnatura per cavo d'acciaio 1766G



1766I

2 017660020

1766G

cavo d'acciaio per cristalli



50 m

1 017660025

Beta
Collection

1767PMC

portaminuterie magnetico tondo



1767PMC

1 017670020

1767PMR

portaminuterie magnetico rettangolare



1767PMR

1 017670010

1770

cutter extra piatto
fornito con 2 lame di ricambio



1770

10 017700001

1770A

cutter con blocco automatico della lama,
fornito con 2 lame di ricambio



1770A

10 017700025

1770RL

10 lame a settori 9 mm
per cutter 1770 e 1770A



1770RL

5 017700010

1771

cutter
fornito con 2 lame di ricambio



1771

10 017710001

1771F

cutter
fornito con lama di ricambio



1771F

20 017710030

1771BM

cutter
fornito con 6 lame di ricambio



1771BM

10 017710050

1771RL

10 lame a settori 18 mm
per cutter 1771, 1771BM e 1771F



1771RL

10 017710010

1772B

cutter a lama retrattile,
fornito con lama di ricambio



1772B

10 017720005

1772J

cutter a lama fissa,
fornito con lama di ricambio



1772J

5 017720021

1772Y

cutter a lama retrattile,
fornito con lama di ricambio



1772Y

5 017720025

1772H

cutter a lama retrattile di sicurezza,
fornito con lama di ricambio



1772H

5 017720029

1772RL/1

10 lame trapezoidali, in astuccio,
per cutter 1772B, 1772J,
1772Y, 1772H, 1777T



1772RL/1

10 017720015

1772RL/2

10 lame trapezoidali lunghe, in astuccio,
per cutter 1772B, 1772J,
1772Y, 1772H, 1774, 1777T

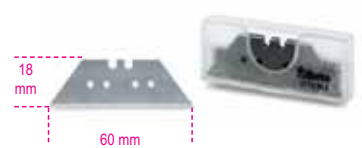

1772RL/2

10 017720017

1772RL/3

10 lame trapezoidali ad uncino doppio, in astuccio, per cutter 1772B, 1777T



1772RL/3 10 017720019

1773

cutter



1773 10 017730001

1773RL

10 lame a settori 25 mm per cutter 1773



1773RL 10 017730015

1774

raschietto multiuso con salvalama di protezione



1774 5 017740001

1774A

raschietto multiuso con impugnatura bimateriale



1774A 1 017740011

1774A/RL

10 lame per raschietto 1774A



1774A/RL 1 017740511

1777BM

coltello a serramanico con gola spellafili
lama in acciaio inossidabile



1777BM 5 017770100

1777T

cutter a serramanico con lama trapezoidale
impugnatura in alluminio, fornito con 5 lame di ricambio



1777T 5 017770030

1777MQ

cutter



1777MQ 2 017770010

1777RL/4

lama trapezoidale lunga per cutter 1777MQ

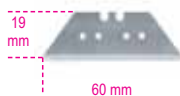

1777RL/4 10 017770020

1778A

coltello a serramanico
lama in acciaio inossidabile
impugnatura in alluminio



1778A 5 017780001

1778B

coltello a serramanico
lama in acciaio inossidabile
impugnatura in alluminio



1778B 5 017780010

1778C

coltello a serramanico
lama in acciaio inossidabile
impugnatura con inserti in legno



1778C 5 017780020

1778M

coltello a serramanico
lama in acciaio inossidabile
impugnatura in alluminio con custodia



1778M 5 017780040

1778N

coltello a serramanico
lama in acciaio inossidabile
impugnatura con finitura soft-touch



1778N 5 017780030

1778X

coltelli per nautica in acciaio inossidabile
impugnatura in alluminio



1778X 2 017780050

1779

pinzetta autobloccante
becchi arrotondati, zigrinati
in acciaio inossidabile



1779 5 017790001

1781

forbici a lame lunghe sottili



1781 5 017810001

1783

forbici modello leggero



L mm

215 5 017830021

240 5 017830024

1784

forbici modello pesante



L mm

175 5 017840017

200 5 017840020

250 5 017840025

300 2 017840030

1810saldatore istantaneo
fornito con punta 1824R10

1810 1 018100001

1812

saldatore istantaneo



1812 1 018120001

1814/20 - 30 - 40saldatori a stilo
con punta acciata 1824R14

1814/20 20W - 10A 320°C 1 018140020

1814/30 30W - 10A 370°C 1 018140030

1814/40 40W - 10A 380°C 1 018140040

1816Asaldatore a doppia potenza
con punta acciata 1824R14

1816A 1 018160010

1818Asaldatore con controllo termostatico
con punta diritta acciata 1824R14

1818A 1 018180001

1820/30 - 50 - 80saldatori a stilo
con punta in rame 1824R20

1820/30 30W - 10A 380°C L = 255 mm 1 018200030

1820/50 50W - 10A 400°C L = 265 mm 1 018200050

1820/80 80W - 10A 410°C L = 280 mm 1 018200080

1822A/...saldatori a martello
con punta 1824R22A

1822A/1 100W - 10A 430°C LxA = 250x130 mm 1 018220410

1822A/2 180W - 10A 460°C LxA = 260x145 mm 1 018220420

1822A/3 280W - 10A 460°C LxA = 270x165 mm 1 018220430

1822A/4 400W - 10A 480°C LxA = 320x170 mm 1 018220440

1822A/5 500W - 10A 480°C LxA = 330x195 mm 1 018220450

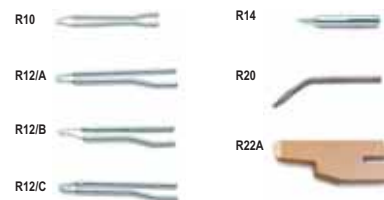
1824R...punte di ricambio
per saldatori

1824R10 1 018240001

1824R12/A 1812 1 018240003

1824R12/B 1812 1 018240005

1824R12/C 1812 1 018240007

1824R14 1814/20-30-40 1816A-1818A 1 018240009

1824R20/3 1820/30 1 018240019

1824R20/5 1820/50 1 018240021

1824R20/8 1820/80 1 018240023

1824R22A/1 1822A/1 1 018240041

1824R22A/2 1822A/2 1 018240042

1824R22A/3 1822A/3 1 018240043

1824R22A/4 1822A/4 1 018240044

1824R22A/5 1822A/5 1 018240045

1825A

stazione di **saldatura**
a controllo digitale
fornita con saldatore



- Regolazione continua della temperatura da 150°C a 400°C con precisione ±1%.
- Funzione di memoria per salvataggio temperatura selezionata al momento dello spegnimento.
- Funzione di blocco temperatura scelta con disattivazione della tastiera mediante password.
- Funzione di selezione di una delle quattro temperature pre-memorizzate (250°C-300°C-350°C-400°C).

1825A 1 018250021

1825A/RS

saldatore di ricambio
per 1825A



1825A/RS 1 018250030

1825A/RS1

punte di ricambio per 1825A
e 1825A/RS



1825A/RS1 1 018250031

1826

stazione di **dissaldatura**
a controllo digitale
fornita con dissaldatore



- Regolazione continua della temperatura da 150°C a 400°C con precisione ±1%.
- Funzione di memoria per salvataggio temperatura selezionata al momento dello spegnimento.
- Funzione di blocco temperatura scelta con disattivazione della tastiera mediante password.
- Funzione di selezione di una delle quattro temperature pre-memorizzate (250°C-300°C-350°C-400°C).

1826 1 018260001

1826/RD

dissaldatore di ricambio
per 1826



1826/RD 1 018260010

1826/RP

punte di ricambio per 1826 e 1826/RD



1826/RP 1 018260051

1827

saldatore a gas regolabile



1827 1 018270001

1827PC

punte di ricambio coniche per 1827



1827PC/1,6 1 018270501
1827PC/3,2 1 018270502

1827PCL

punte di ricambio a coltello per 1827



1827PCL/2,4 1 018270503

1827PFL

punte di ricambio a fiamma libera
per 1827



1827PFL 1 018270504

1827/K

saldatore a gas con 7 accessori
in valigetta con base morbida
di polietilene espanso



- Potenza: da 30 Watt a 125 Watt.
- Temperatura della punta regolabile da 250°C a 500°C.
- Regolatore del flusso di gas.
- Tempo di riscaldamento: 15 secondi dopo l'accensione.
- Il serbatoio contiene gas per 120 minuti di utilizzo continuato.
- Serbatoio trasparente per monitorare il livello di gas.
- Ricaricabile con gas butano.

1827/K 1 018270100

1830

pompette per dissaldare
con ugello antistatico in Teflon®



1830 5 018300001

1834/70

torcia LED ad alta luminosità
in robusto alluminio anodizzato,
fino a 70 Lumen

- Pile 2xAA (non include)



1834/70 1 018340010

1834/150

torcia LED ad alta luminosità
in robusto alluminio anodizzato,
fino a 150 Lumen
con doppia intensità luminosa

- Pile 3xAAA (non include)



1834/150 1 018340020

1834/200

torcia LED ad alta luminosità
in robusto alluminio anodizzato,
fino a 200 Lumen
con doppia intensità luminosa
e indicatore di carica
• Pile 3xD (non incluse)



1834/200 1 018340030

1835

lampada stilo
fornita con lampada di ricambio
• Pile 2xAA (non incluse)



1835 5 018350001

1838

lampada a LED ricaricabile
batteria ai polimeri di litio



- Resistente ad acqua, olii e grasso
- Appendibile, con corpo in gomma antiscivolo e antiurto
- Batteria ai polimeri di Litio: leggera e di lunga autonomia (8 ore)
- 30 LED da 100.000 ore ad alta luminosità
- LED frontale di segnalazione batteria scarica
- Nessun effetto memoria

1838 1 018380001



1840

portalampana portatile
per lampada ad incandescenza
• Lampada esclusa



IP20

1840 1 018400001

1840B

portalampana portatile
per lampada ad incandescenza
• Lampada esclusa



IP65

1840B 1 018400020

1841

portalampana portatile
completo di lampada fluorescente



IP55

1841 1 018410001

1841A

portalampana portatile
completo di lampada fluorescente



IP55

1841A 1 018410010

1844/24

avvolgicavo automatico
completo di portalampana
e lampada fluorescente a 24V

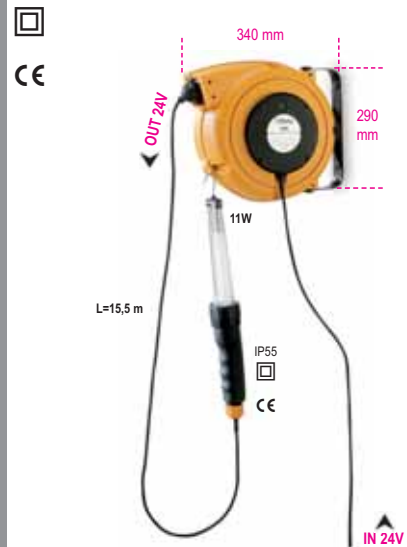

IP42

1844/24 1 018440002

1844/230

avvolgicavo automatico
con trasformatore
completo di portalampana
e lampada fluorescente a 24V



IP42

1844/230 1 018440004

1844RP

portalamпада di ricambio
per 1844/24 e 1844/230
con lampada fluorescente



IP55



1844RP

1 018440010

1845/24

avvolgicavo automatico
completo di portalamпада
per lampada ad incandescenza

• Lampada esclusa



IP42

1845/24

1 018450002

1845/230

avvolgicavo automatico
con trasformatore
completo di portalamпада
per lampada ad incandescenza

• Lampada esclusa



IP42

1845/230

1 018450004

1845RP/1

portalamпада di ricambio
per 1845/24 e 1845/230

• Lampada esclusa



IP65



1845RP/1

1 018450021

1847

tester combinato di tensione
e di continuit 



IP50

EN 61243-3

DATI TECNICI

Campo di tensione: 6÷400V AC/DC

Gamma di frequenza: 0÷100Hz; indicazione di AC con f-2Hz

Resistenza a tensioni di punta: 4 kV

Resistenza d'entrata: ≥300 kΩ

Corrente d'entrata: Is < 2,5 mA a 400V

Prova di continuit : < 500 kΩ

2 batterie da 1,5V incluse

1847

1 018470001

1847K

rilevatore di tensione AC senza contatto
con mini-torcia LED



IP50

EN 61243-3

Campo di rilevamento: 110÷230V AC

1847K

1 018470101

1850B

pistola termica 2 velocit 

- Pos. I 240 l/min 300°C

- Pos. II 450 l/min 500°C

• possibilit  di utilizzo con la pistola
appoggiata verticalmente su un piano



1850B

1 018500011

1850C

pistola termica
con regolazione elettronica

- Pos. I 150-250 l/min 50°C

- Pos. II 150-500 l/min 50-650°C

- Display digitale.
- Pulsanti regolazione temperatura e portata del flusso.
- Possibilit  di utilizzo con la pistola appoggiata verticalmente su un piano.
- 4 programmi memorizzati in origine e possibilit  di personalizzazioni

- Prog 1 250°C ca. 350 l/min

- Prog 2 350°C ca. 400 l/min

- Prog 3 450°C ca. 500 l/min

- Prog 4 550°C ca. 400 l/min



1850C

1 018500015

1850U...

ugelli per 1850B e 1850C

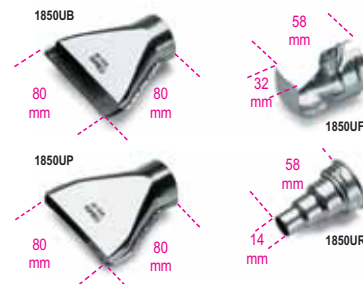

1850UB	B-C	1 018500100
1850UF	B-C	1 018500101
1850UP	B-C	1 018500102
1850UR	C	1 018500103



1851VK

pistola per colla a caldo con 12 stick di colla termofusibile in valigetta

Ø 11 e 12 mm

CE



1851VK 1 018510058

1860K/140A

saldatrici con tecnologia inverter, adatte per motogeneratori, compatte e facili da trasportare, fornite di cavi, martospazzola, maschera e tracolla.



Corrente di regolazione: 5+130A
Alimentazione: 1x230V
Potenza assorbita: MAX 3,0 KVA
Fattore di utilizzo: 35% - 130 A
60% - 80 A
100% - 70 A
Fusibile ritardato: 20 A
Protezione: IP23
Temperatura di esercizio: -15/+40° C (+5/+104° F)
Elettrodi utilizzabili: Ø 1.5 - 3.25mm



1860K/140A 1 018600014

1860K/160A

saldatrici con tecnologia inverter, adatte per motogeneratori, compatte e facili da trasportare, fornite di cavi, martospazzola, maschera e tracolla.



Corrente di regolazione: 5+155A
Alimentazione: 1x230V
Potenza assorbita: MAX 3,7 KVA
Fattore di utilizzo: 35% - 150 A
60% - 130 A
100% - 100 A
Fusibile ritardato: 20 A
Protezione: IP21
Temperatura di esercizio: -15/+40° C (+5/+104° F)
Elettrodi utilizzabili: Ø 1.5 - 4mm



1860K/160A 1 018600016

1860R/C

cavi e pinze per inverter 1860K



1860R/C 1 018600501

1901

avvolgitubo automatico
corpo in materiale plastico antiurto
per aria compressa o acqua fredda

• Pressione di utilizzo max 12 Bar

CE



1901 1 019010001

1910

avvolgitubo automatico
corpo in alluminio
per aria compressa o acqua fredda

• Pressione di utilizzo max 12 Bar

CE



1910 1 019100001

1915B

spirali in poliuretano 95 Shore
estensibili fino a 9 m

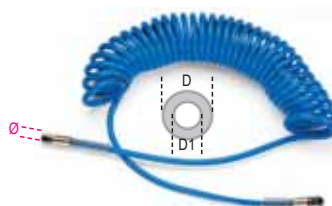

D1xD mm	Ø GAS BSP	1	019150011
6,5x10	1/4"	1	019150012
8x12	1/4"	1	019150013
11x16	3/8"	1	019150013

1915C

spirali in poliuretano 95 Shore
estensibili fino a 12 m

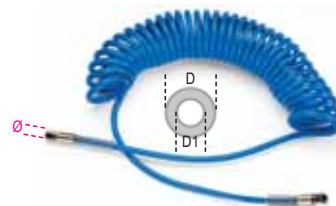

D1xD mm	Ø GAS BSP	1	019150014
6,5x10	1/4"	1	019150015
8x12	1/4"	1	019150016
11x16	3/8"	1	019150016

1915D

tubo in poliuretano retinato 95 Shore
lunghezza 9 m



D1xD mm	Ø GAS BSP	1	019150017
8x12	1/4"	1	019150018
11x16	3/8"	1	019150018

1915E

tubo in poliuretano retinato 95 Shore
lunghezza 12 m



D1xD mm	Ø GAS BSP	1	019150019
8x12	1/4"	1	019150020
11x16	3/8"	1	019150020

1916I

innesti rapidi profilo Italia
in ottone nichelato
filettati maschio, GAS cilindrici BSP



Ø GAS BSP	5	019160001
1/4"	5	019160002
3/8"	5	019160002

1916G

innesti rapidi profilo Europa
in acciaio carbonitrurato
zincato filettati maschio, GAS conici BSPT



Ø GAS BSPT		
1/4"	5	019160005
3/8"	5	019160010

1917M

raccordi universali a sfera
con gomma antiurto
in ottone nichelato
filettati maschio GAS cilindrici BSP



Ø GAS BSP		
1/4"	5	019170001
3/8"	5	019170003

1917F

raccordi universali a sfera con gomma
antiurto in ottone nichelato
filettati femmina GAS cilindrici BSP



Ø GAS BSP		
1/4"	5	019170005
3/8"	5	019170010

1918

occhiali di protezione
visiera in policarbonato
guscio in PVC

CE



EN 166

1918	5	019180001
------	---	-----------

1918C

cuffia antirumore, in PVC

- attenuano da 15,4 dB a 63 Hz
sino a 37 dB a 8000 Hz

CE



EN 352-1

1918C	2	019180002
-------	---	-----------

1918M

mascherina antipolvere

CE



EN 149FFP1

1918M	20	019180003
-------	----	-----------

1919FE1/4

filtro regolatore lubrificatore

Ø 1/4"



Attacchi aria entrata/uscita	1/4" GAS BSPT
Attacco manometro	1/8" GAS BSPT
Portata massima	750 l/min
Pressione massima	9,5 Bar
Pressione di utilizzo	0,5 - 8,5 Bar
Temperatura di utilizzo	5 - 60 °C
Capacità filtrante	5 micron
Capacità tazze	15 cc aria / 25 cc olio

g	1	019190200
---	---	-----------

1919RB-FE1/4

coppia bicchieri di ricambio
per 1919FE1/4



1919RB-FE1/4	1	019190210
--------------	---	-----------

1919RF-FE1/4

ricambio elemento filtrante
per 1919FE1/4



1919RF-FE1/4	1	019190230
--------------	---	-----------

1919RM-FE1/4

manometro di ricambio
per 1919FE1/4



1919RM-FE1/4	1	019190220
--------------	---	-----------

1919F1/4

filtro regolatore lubrificatore

Ø 1/4"



Attacchi aria entrata/uscita	1/4" GAS BSPT
Portata massima	1000 l/min
Pressione massima	9,5 Bar
Pressione di utilizzo	0,5 - 8,5 Bar
Temperatura di utilizzo	5 - 60 °C
Capacità filtrante	5 micron
Capacità tazze	80 cc aria / 90 cc olio

kg	1,3	019190250
----	-----	-----------

Beta

1919F3/8

filtro regolatore lubrificatore



Attacchi aria entrata/uscita 3/8" GAS BSPT
 Portata massima 1350 l/min
 Pressione massima 9,5 Bar
 Pressione di utilizzo 0,5 - 8,5 Bar
 Temperatura di utilizzo 5 - 60 °C
 Capacità filtrante 5 micron
 Capacità tazze 60 cc aria / 90 cc olio

kg 1,3 1 019190350

1919F1/2

filtro regolatore lubrificatore



Attacchi aria entrata/uscita 1/2" GAS BSPT
 Portata massima 2500 l/min
 Pressione massima 9,5 Bar
 Pressione di utilizzo 0,5 - 8,5 Bar
 Temperatura di utilizzo 5 - 60 °C
 Capacità filtrante 5 micron
 Capacità tazze 60 cc aria / 90 cc olio

kg 1,3 1 019190450

1919RB-F

coppia bicchieri
per filtri 1919F - 1/4", 3/8" e 1/2"



1919RB-F 1 019190510

1919RF-F

ricambio elemento filtrante
per filtri 1919F - 1/4", 3/8" e 1/2"



1919RF-F 1 019190530

1919RM-F

manometro di ricambio
per filtri 1919F - 1/4", 3/8" e 1/2"



1919RM-F 1 019190520

1919ML

mini lubrificatori di linea



Ø 1/4" 1 019190030
 Ø 3/8" 1 019190032

1919SC

mini separatore di condensa



Ø 1/4" 1 019190035

1919L

olio lubrificatore ISO 32

Densità a 20°C
 Viscosità a 40°C
 Infiammabilità COC
 Congelamento

875 Kg/m³
 32 cSt
 210°C
 -33°C



cc 500 5 019190050

1920C

cricchetto reversibile compatto

3/8"

CE



Velocità libera 250 giri/min
 Coppia massima 34 Nm
 Pressione di utilizzo 6,2 Bar
 Consumo aria medio 70 l/min
 Ø interno tubo aria 6 mm
 Capacità vite/dado CI 8.8 M7 ● 11 mm
 Capacità vite/dado CI 12.9 M6 ● 10 mm

3/8 520 1 019200002

1920CR

kit manutenzione per 1920C e 1923C

1920CR 1 019200012

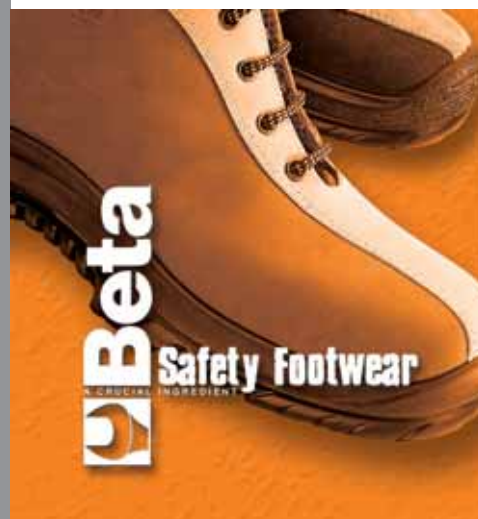

1920L

cricchetto reversibile

3/8"

CE



Velocità libera	160 giri/min
Coppia massima	67 Nm
Pressione di utilizzo	6,2 Bar
Consumo aria medio	135 l/min
Ø interno tubo aria	6 mm
Capacità vite/dado	Cl 8.8 M10 ● 16 mm
Capacità vite/dado	Cl 12.9 M8 ● 13 mm

3/8"	1,2 kg	1	019200005
------	--------	---	-----------

1920LR

kit manutenzione per 1920L e 1922

1920LR	1	019200015
--------	---	-----------

1922

cricchetto reversibile

1/2"

CE



Velocità libera	160 giri/min
Coppia massima	67 Nm
Pressione di utilizzo	6,2 Bar
Consumo aria medio	135 l/min
Ø interno tubo aria	6 mm
Capacità vite/dado	Cl 8.8 M10 ● 16 mm
Capacità vite/dado	Cl 12.9 M8 ● 13 mm

1/2"	1,25 kg	1	019220001
------	---------	---	-----------

1920LR

kit manutenzione per 1920L e 1922

1920LR	1	019200015
--------	---	-----------

1922I

cricchetto reversibile a martelli

1/2"

CE



Velocità libera	350 giri/min
Coppia massima	90 Nm
Pressione di utilizzo	6,2 Bar
Consumo aria medio	170 l/min
Ø interno tubo aria	8 mm
Capacità vite/dado	Cl 8.8 M10 ● 16 mm
Capacità vite/dado	Cl 12.9 M8 ● 13 mm

1/2"	1,54 kg	1	019220005
------	---------	---	-----------

1922IR

kit manutenzione per 1922I

1922IR	1	019220015
--------	---	-----------

1923C

cricchetto reversibile compatto

1/4"

CE



Velocità libera	250 giri/min
Coppia massima	34 Nm
Pressione di utilizzo	6,2 Bar
Consumo aria medio	70 l/min
Ø interno tubo aria	6 mm
Capacità vite/dado	Cl 8.8 M7 ● 11 mm
Capacità vite/dado	Cl 12.9 M6 ● 10 mm

1/4"	520 g	1	019230002
------	-------	---	-----------

1920CR

kit manutenzione per 1920C e 1923C

1920CR	1	019200012
--------	---	-----------

1923SA

cricchetto reversibile silenziato

3/8"

CE



Velocità libera	180 giri/min
Coppia massima	90 Nm
Pressione di utilizzo	6,2 Bar
Consumo aria medio	170 l/min
Ø interno tubo aria	8 mm
Capacità vite/dado	Cl 8.8 M10 ● 16 mm
Capacità vite/dado	Cl 12.9 M8 ● 13 mm

3/8"	1,3 kg	1	019230030
------	--------	---	-----------

1923SAR

kit manutenzione per 1923SA e 1923SB

1923SAR	1	019230035
---------	---	-----------

1923SB

cricchetto reversibile silenziato

1/2"

CE



Velocità libera	180 giri/min
Coppia massima	90 Nm
Pressione di utilizzo	6,2 Bar
Consumo aria medio	170 l/min
Ø interno tubo aria	8 mm
Capacità vite/dado	Cl 8.8 M10 ● 16 mm
Capacità vite/dado	Cl 12.9 M8 ● 13 mm

1/2"	1,3 kg	1	019230040
------	--------	---	-----------

1923SAR

kit manutenzione per 1923SA e 1923SB

1923SAR	1	019230035
---------	---	-----------

1924CD

avvitatore reversibile in materiale composito

- Meccanismo impulsivo doppio martello



Velocità libera	10000 giri/min
Coppia massima	410 Nm
Coppia d'esercizio	250 Nm
Attacco aria	1/4" GAS
Pressione di utilizzo	6,2 Bar
Consumo aria medio	79 l/min
Ø interno tubo aria	8 mm
Capacità vite/dado	CI 8.8 M16 ● 24 mm
Capacità vite/dado	CI 12.9 M14 ● 21 mm

■	kg	☛	☛
3/8	1,25	1	019240007

1928CD

avvitatore reversibile in materiale composito

- Meccanismo impulsivo doppio martello



Velocità libera	4500 giri/min
Coppia massima	1800 Nm
Coppia d'esercizio	1290 Nm
Attacco aria	3/8" GAS
Pressione di utilizzo	6,2 Bar
Consumo aria medio	215 l/min
Ø interno tubo aria	10 mm
Capacità vite/dado	CI 8.8 M27 ● 41 mm
Capacità vite/dado	CI 12.9 M22 ● 34 mm

■	kg	☛	☛
3/4	3,5	1	019280007

1930NCD

avvitatore reversibile in materiale composito

- Meccanismo impulsivo doppio martello



Velocità libera	4000 giri/min
Coppia massima	2445 Nm
Pressione di utilizzo	6,2 Bar
Consumo aria medio	410 l/min
Ø interno tubo aria	13 mm
Capacità vite/dado	CI 8.8 M36 ● 55 mm
Capacità vite/dado	CI 12.9 M30 ● 46 mm

■	kg	☛	☛
1	8,75	1	019300027

1927CD

avvitatore reversibile in materiale composito

- Meccanismo impulsivo doppio martello



Velocità libera	7000 giri/min
Coppia massima	1020 Nm
Coppia d'esercizio	610 Nm
Attacco aria	1/4" GAS
Pressione di utilizzo	6,2 Bar
Consumo aria medio	130 l/min
Ø interno tubo aria	8 mm
Capacità vite/dado	CI 8.8 M22 ● 34 mm
Capacità vite/dado	CI 12.9 M18 ● 27 mm

■	kg	☛	☛
1/2	1,9	1	019270007

1930CD

avvitatore reversibile in materiale composito

- Meccanismo impulsivo doppio martello



Velocità libera	4000 giri/min
Coppia massima	2445 Nm
Pressione di utilizzo	6,2 Bar
Consumo aria medio	410 l/min
Ø interno tubo aria	13 mm
Capacità vite/dado	CI 8.8 M36 ● 55 mm
Capacità vite/dado	CI 12.9 M30 ● 46 mm

■	kg	☛	☛
1	7,1	1	019300022

1930HCD

avvitatore reversibile in materiale composito

- Meccanismo impulsivo doppio martello



Velocità libera	4000 giri/min
Coppia massima	2711 Nm
Pressione di utilizzo	6,2 Bar
Consumo aria medio	460 l/min
Ø interno tubo aria	13 mm
Capacità vite/dado	CI 8.8 M39 ● 60 mm
Capacità vite/dado	CI 12.9 M33 ● 50 mm

■	kg	☛	☛
1	10,2	1	019300028

1927KP

avvitatore reversibile con 4 bussole macchina serie lunga in valigetta

- Meccanismo impulsivo doppio martello

12"

CE



720L 17-19-21-22 mm

Velocità libera 8000 giri/min
 Coppia massima 540 Nm
 Attacco aria 1/4" GAS
 Pressione di utilizzo 6,2 Bar
 Consumo aria medio 300 l/min
 Ø interno tubo aria 8 mm
 Capacità vite/dado CI 8.8 M16●24 mm
 Capacità vite/dado CI 12.9 M14●21 mm
 Peso avvitatore 2,7 Kg

"	kg		
1/2	4,5	1	019270100

1928KP

avvitatore reversibile con 4 bussole macchina serie lunga in valigetta

- Meccanismo impulsivo "Pin Clutch"

3/4"

CE



728L 27-30-32-36 mm

Velocità libera 5000 giri/min
 Coppia massima 1360 Nm
 Attacco aria 3/8" GAS
 Pressione di utilizzo 6,2 Bar
 Consumo aria medio 380 l/min
 Ø interno tubo aria 10 mm
 Capacità vite/dado CI 8.8 M24●36 mm
 Capacità vite/dado CI 12.9 M22●34 mm
 Peso avvitatore 5,1 Kg

"	kg		
3/4	7,0	1	019280100

1924

avvitatore reversibile

- Meccanismo impulsivo martello singolo oscillante

3/8"

CE



Velocità libera 10000 giri/min
 Coppia massima 103 Nm
 Pressione di utilizzo 6,2 Bar
 Consumo aria medio 175 l/min
 Ø interno tubo aria 8 mm
 Capacità vite/dado CI 8.8 M10●16 mm
 Capacità vite/dado CI 12.9 M8●13 mm

"	kg		
3/8	1,25	1	019240001

1924R

kit manutenzione per 1924

1924R	1	019240010
-------	---	-----------

1924S

avvitatore reversibile silenziato

- Meccanismo impulsivo doppio martello

3/8"

CE



Velocità libera 10000 giri/min
 Coppia massima 280 Nm
 Pressione di utilizzo 6,2 Bar
 Consumo aria medio 250 l/min
 Ø interno tubo aria 8 mm
 Capacità vite/dado CI 8.8 M16●24 mm
 Capacità vite/dado CI 12.9 M14●21 mm

"	kg		
3/8	1,6	1	019240005

1924SR

kit manutenzione per 1924S

1924SR	1	019240015
--------	---	-----------

1926S

avvitatore reversibile silenziato

- Meccanismo impulsivo "Pin Clutch"

12"

CE



Velocità libera 8000 giri/min
 Coppia massima 575 Nm
 Pressione di utilizzo 6,2 Bar
 Consumo aria medio 320 l/min
 Ø interno tubo aria 10 mm
 Capacità vite/dado CI 8.8 M22●34 mm
 Capacità vite/dado CI 12.9 M18●27 mm

"	kg		
1/2	2,3	1	019260008

1926SR

kit manutenzione per 1926S

1926SR	1	019260018
--------	---	-----------

1926SD

avvitatore reversibile silenziato

- Meccanismo impulsivo doppio martello

12"

CE



Velocità libera 7000 giri/min
 Coppia massima 610 Nm
 Pressione di utilizzo 6,2 Bar
 Consumo aria medio 300 l/min
 Ø interno tubo aria 10 mm
 Capacità vite/dado CI 8.8 M22●34 mm
 Capacità vite/dado CI 12.9 M18●27 mm

"	kg		
1/2	2,6	1	019260009

1926SDR

kit manutenzione per 1926SD

1926SDR	1	019260019
---------	---	-----------

1927A

avvitatore reversibile

- Meccanismo impulsivo "Pin Clutch"

12"

CE



Velocità libera 7000 giri/min
 Coppia massima 610 Nm
 Pressione di utilizzo 6,2 Bar
 Consumo aria medio 300 l/min
 Ø interno tubo aria 8 mm
 Capacità vite/dado CI 8.8 M22 ● 34 mm
 Capacità vite/dado CI 12.9 M18 ● 27 mm

1/2 2,7

1 019270002

1928ND

avvitatore reversibile

- Meccanismo impulsivo doppio martello

3/4"

CE



Velocità libera 5000 giri/min
 Coppia massima 1100 Nm
 Pressione di utilizzo 6,2 Bar
 Consumo aria medio 380 l/min
 Ø interno tubo aria 10 mm
 Capacità vite/dado CI 8.8 M27 ● 41 mm
 Capacità vite/dado CI 12.9 M22 ● 34 mm

3/4 4,45

1 019280002

1928NDR

kit manutenzione per 1928ND

1928NDR

1 019280012

1930PA

avvitatore reversibile

- Meccanismo impulsivo doppio martello

1"

CE



Velocità libera 3500 giri/min
 Coppia massima 2445 Nm
 Pressione di utilizzo 6,2 Bar
 Consumo aria medio 410 l/min
 Ø interno tubo aria 13 mm
 Capacità vite/dado CI 8.8 M36 ● 55 mm
 Capacità vite/dado CI 12.9 M30 ● 46 mm

1 9,6

1 019300032

1927D

avvitatore reversibile

- Meccanismo impulsivo doppio martello

12"

CE



Velocità libera 9000 giri/min
 Coppia massima 610 Nm
 Pressione di utilizzo 6,2 Bar
 Consumo aria medio 380 l/min
 Ø interno tubo aria 10 mm
 Capacità vite/dado CI 8.8 M22 ● 34 mm
 Capacità vite/dado CI 12.9 M18 ● 27 mm

1/2 2,65

1 019270003

1928S

avvitatore reversibile silenziato

- Meccanismo impulsivo doppio martello

3/4"

CE



Velocità libera 4200 giri/min
 Coppia massima 1195 Nm
 Pressione di utilizzo 6,2 Bar
 Consumo aria medio 400 l/min
 Ø interno tubo aria 10 mm
 Capacità vite/dado CI 8.8 M27 ● 41 mm
 Capacità vite/dado CI 12.9 M22 ● 34 mm

3/4 5,7

1 019280008

1930ND

avvitatore reversibile

- Meccanismo impulsivo doppio martello

1"

CE

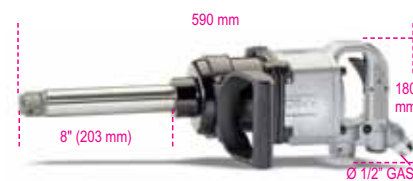

Velocità libera 3800 giri/min
 Coppia massima 2500 Nm
 Pressione di utilizzo 6,2 Bar
 Consumo aria medio 400 l/min
 Ø interno tubo aria 13 mm
 Capacità vite/dado CI 8.8 M36 ● 55 mm
 Capacità vite/dado CI 12.9 M30 ● 46 mm

1 14

1 019300008

1927DR

kit manutenzione per 1927D

1927DR

1 019270013

1928SR

kit manutenzione per 1928S

1928SR

1 019280018

1930NDR

kit manutenzione per 1930ND

1930NDR

1 019300018

1930DL

avvitatore reversibile

• Meccanismo impulsivo doppio martello

1"

CE

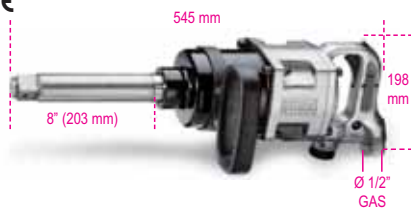

Velocità libera	4200 giri/min
Coppia massima	2445 Nm
Pressione di utilizzo	6,2 Bar
Consumo aria medio	560 l/min
Ø interno tubo aria	13 mm
Capacità vite/dado	Cl 8.8 M36 ● 55 mm
Capacità vite/dado	Cl 12.9 M30 ● 46 mm

kg	10,5	1	019300007
----	------	---	-----------

1930DLR

kit manutenzione per 1930DL

1930DLR	1	019300017
---------	---	-----------

1932A

trapano non reversibile

CE

CE



Capacità mandrino	1,5÷10 mm
Filettatura albero	3/8" - 24UNF
Velocità libera	2200 giri/min
Potenza	0,44 Kw
Pressione di utilizzo	6,2 Bar
Consumo aria medio	250 l/min
Ø interno tubo aria	8 mm

kg	1,06	1	019320001
----	------	---	-----------

1932AR

kit manutenzione per 1932A

1932AR	1	019320021
--------	---	-----------

1932B

trapano reversibile

CE

CE



Capacità mandrino	1,5÷10 mm
Filettatura albero	3/8" - 24UNF
Velocità libera	1200 giri/min
Potenza	0,44 Kw
Pressione di utilizzo	6,2 Bar
Consumo aria medio	250 l/min
Ø interno tubo aria	8 mm

kg	1,26	1	019320005
----	------	---	-----------

1932BR

kit manutenzione per 1932B

1932BR	1	019320025
--------	---	-----------

1932AN

trapano angolare reversibile

CE

CE



Capacità mandrino	1,5÷10 mm
Filettatura albero	3/8" - 24UNF
Velocità libera	1800 giri/min
Potenza	0,44 Kw
Pressione di utilizzo	6,2 Bar
Consumo aria medio	250 l/min
Ø interno tubo aria	8 mm

kg	1,12	1	019320007
----	------	---	-----------

1932ANR

kit manutenzione per 1932AN

1932ANR	1	019320027
---------	---	-----------

1932I

trapano non reversibile

CE

CE



Capacità mandrino	1,5÷13 mm
Filettatura albero	1/2" - 20UNC
Velocità libera	500 giri/min
Potenza	0,44 Kw
Pressione di utilizzo	6,2 Bar
Consumo aria medio	250 l/min
Ø interno tubo aria	8 mm

kg	1,79	1	019320010
----	------	---	-----------

1932IR

kit manutenzione per 1932I

1932IR	1	019320030
--------	---	-----------

1932RS

trapano reversibile

CE

CE



Capacità mandrino	1,5÷13 mm
Filettatura albero	1/2" - 20UNC
Velocità libera	500 giri/min
Potenza	0,55 Kw
Pressione di utilizzo	6,2 Bar
Consumo aria medio	260 l/min
Ø interno tubo aria	8 mm

kg	1,84	1	019320013
----	------	---	-----------

1932RSR

kit manutenzione per 1932RS

1932RSR	1	019320033
---------	---	-----------

1932S

trapano reversibile silenziato



Capacità mandrino	1±10 mm
Filettatura albero	3/8" - 24UNF
Velocità libera	1500 giri/min
Potenza	0,44 Kw
Pressione di utilizzo	6,2 Bar
Consumo aria medio	250 l/min
Ø interno tubo aria	8 mm

kg
1,1

1 019320002

1932SR

kit manutenzione per 1932S

1932SR

1 019320022

1934

smerigliatrice assiale



Capacità pinza	6 mm
Velocità libera	22000 giri/min
Potenza	0,44 Kw
Pressione di utilizzo	6,2 Bar
Consumo aria medio	340 l/min
Ø interno tubo aria	8 mm

g
620

1 019340001

1934R

kit manutenzione per 1934

1934R

1 019340031

1934S

smerigliatrice assiale silenziata



Capacità pinza	3/6 mm
Velocità libera	22000 giri/min
Potenza	0,44 Kw
Pressione di utilizzo	6,2 Bar
Consumo aria medio	340 l/min
Ø interno tubo aria	8 mm

g
660

1 019340002

1934SR

kit manutenzione per 1934S

1934SR

1 019340032

1934I

smerigliatrice assiale



Capacità pinza	6 mm
Velocità libera	18000 giri/min
Potenza	0,66 Kw
Pressione di utilizzo	6,2 Bar
Consumo aria medio	350 l/min
Ø interno tubo aria	8 mm

g
710

1 019340005

1934IR

kit manutenzione per 1934I

1934IR

1 019340035

1934L

smerigliatrice assiale con albero prolungato



Capacità pinza	6 mm
Velocità libera	24000 giri/min
Potenza	0,22 Kw
Pressione di utilizzo	6,2 Bar
Consumo aria medio	340 l/min
Ø interno tubo aria	8 mm

g
550

1 019340015

1934LR

kit manutenzione per 1934L

1934LR

1 019340040

1934AN

smerigliatrice angolare



Capacità pinza	6 mm
Velocità libera	20000 giri/min
Potenza	0,22 Kw
Pressione di utilizzo	6,2 Bar
Consumo aria medio	250 l/min
Ø interno tubo aria	8 mm

g
500

1 019340020

1934ANR

kit manutenzione per 1934AN

1934ANR

1 019340045

1934AV

levigatrice ad alta velocità



Dimensione mola	75+125 mm
Velocità libera	16000 giri/min
Potenza	0,44 Kw
Pressione di utilizzo	6,2 Bar
Consumo aria medio	310 l/min
Ø interno tubo aria	8 mm

kg	1,19	1	019340025
----	------	---	-----------

1934AVR

kit manutenzione per 1934AV

1934AVR	1	019340050
---------	---	-----------

1935A

giravite reversibile



Velocità libera	800 giri/min
Campo di coppia	4-12 Nm
Pressione di utilizzo	6,2 Bar
Consumo aria medio	370 l/min
Ø interno tubo aria	8 mm
Capacità vite	5-8 M
Porta inserti	● 1/4"

kg	1,2	1	019350010
----	-----	---	-----------

1935AR

kit manutenzione per 1935A

1935AR	1	019350050
--------	---	-----------

1935B

giravite reversibile



Velocità libera	1800 giri/min
Campo di coppia	2-8 Nm
Pressione di utilizzo	6,2 Bar
Consumo aria medio	370 l/min
Ø interno tubo aria	8 mm
Capacità vite	3-6 M
Porta inserti	● 1/4"

kg	1,06	1	019350015
----	------	---	-----------

1935BR

kit manutenzione per 1935B

1935BR	1	019350055
--------	---	-----------

1935C

giravite reversibile



Velocità libera	800 giri/min
Campo di coppia	4-12 Nm
Pressione di utilizzo	6,2 Bar
Consumo aria medio	370 l/min
Ø interno tubo aria	8 mm
Capacità vite	5-8 M
Porta inserti	● 1/4"

kg	1,24	1	019350020
----	------	---	-----------

1935CR

kit manutenzione per 1935C

1935CR	1	019350060
--------	---	-----------

1935D

giravite reversibile



Velocità libera	1800 giri/min
Campo di coppia	2-8 Nm
Pressione di utilizzo	6,2 Bar
Consumo aria medio	370 l/min
Ø interno tubo aria	8 mm
Capacità vite	3-6 M
Porta inserti	● 1/4"

kg	1,09	1	019350025
----	------	---	-----------

1935DR

kit manutenzione per 1935D

1935DR	1	019350065
--------	---	-----------

1936/5

smerigliatrice angolare



Dimensione mola	125 mm
Filettatura albero	M14
Velocità libera	12000 giri/min
Potenza	0,7 Kw
Pressione di utilizzo	6,2 Bar
Consumo aria medio	380 l/min
Ø interno tubo aria	10 mm

kg	1,98	1	019360005
----	------	---	-----------

1936/5R

kit manutenzione per 1936/5

1936/5R	1	019360015
---------	---	-----------

1936/7

smerigliatrice angolare



Dimensione mola 178 mm
 Filettatura albero 5/8" - 11UNC
 Velocità libera 7000 giri/min
 Potenza 1,4 Kw
 Pressione di utilizzo 6,2 Bar
 Consumo aria medio 500 l/min
 Ø interno tubo aria 13 mm

kg 3,4
 1 019360007

1936/7R

kit manutenzione per 1936/7

1936/7R 1 019360017

1938/7

levigatrice angolare



Dimensione massima platello 178 mm
 Filettatura albero 5/8" - 11UNC
 Velocità libera 4500 giri/min
 Potenza 0,6 Kw
 Pressione di utilizzo 6,2 Bar
 Consumo aria medio 350 l/min
 Ø interno tubo aria 10 mm

kg 2,62
 1 019380007

1938/7R

kit manutenzione per 1938/7

1938/7R 1 019380017

1938RP

platello di ricambio per 1938/7



1938RP 5 019380010

1940

martello scalpellatore



Dimensione attacco Ø 11 mm
 Dimensione pistone 19 mm
 Corsa del pistone 67 mm
 Colpi al minuto 3500
 Pressione di utilizzo 6,2 Bar
 Consumo aria medio 240 l/min
 Ø interno tubo aria 8 mm

kg 1,92
 1 019400001

1940R

kit manutenzione per 1940

1940R 1 019400101

1940MT

molla di tenuta per 1940



1940MT 5 019400110

1940HD

martello scalpellatore



Dimensione attacco Ø 11 mm
 Dimensione pistone 19 mm
 Corsa del pistone 58 mm
 Colpi al minuto 3000
 Pressione di utilizzo 6,2 Bar
 Consumo aria medio 280 l/min
 Ø interno tubo aria 8 mm

kg 1,86
 1 019400002

1940HDR

kit manutenzione per 1940HD

1940HDR 1 019400102

1940MT/HD

molla di tenuta per 1940HD



1940MT/HD 5 019400111

1940S...

scalpelli per martelli scalpellatori 1940 e 1940HD



1940SN 5 019400020
 1940ST 5 019400021
 1940SD 5 019400022
 1940SPS 5 019400023
 1940SDT 5 019400024

1940/S5

serie di 5 scalpelli
per martelli scalpellatori 1940 e 1940HD



1940/S5

1 019400030

1942

seghetto alternativo

CE

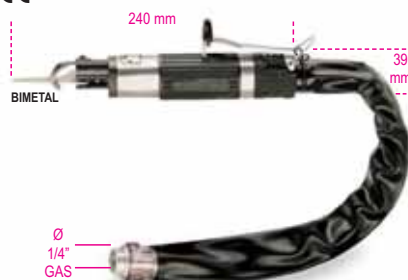

Corse al minuto	5000
Lunghezza della corsa	10 mm
Pressione di utilizzo	6,2 Bar
Consumo aria medio	200 l/min
Ø interno tubo aria	6 mm

kg 1,92 1 019420001

1942R

kit manutenzione per 1942

1942R 1 019420010

1942S

seghetto alternativo silenziato

CE



Corse al minuto	9000
Lunghezza della corsa	10 mm
Pressione di utilizzo	6,2 Bar
Consumo aria medio	110 l/min
Ø interno tubo aria	8 mm

g 700 1 019420002

1942SR

kit manutenzione per 1942S

1942SR 1 019420012

1942LR

lame Bimetal
per seghetto alternativo 1942



1942LR 5 019420032

1944

raschietto ad aghi

CE



Ø aghi	3 mm
Corsa del pistone	33 mm
Colpi al minuto	3000
Pressione di utilizzo	6,2 Bar
Consumo aria medio	160 l/min
Ø interno tubo aria	8 mm

kg 2,63 1 019440001

1944R

kit manutenzione per 1944

1944R 1 019440010

1944AR

set di 19 aghi
per raschietto 1944



1944AR 1 019440005

1946

rivettatrice

• fornita con ugelli intercambiabili da 2,4 - 3,2 - 4,0 - 4,8 mm



Potenza di trazione	8000 N
Lunghezza della corsa	14 mm
Pressione di utilizzo	6,2 Bar
Consumo aria	1,2 l/ciclo
Ø interno tubo aria	6 mm
Capacità massima rivetti	Ø alluminio 4,8 mm

kg
1,51



1946R

kit manutenzione per 1946



1946A

rivettatrice con aspiratore

• fornita con ugelli intercambiabili da 2,4 - 3,2 - 4,0 - 4,8 mm



Potenza di trazione	8300 N
Lunghezza della corsa	14 mm
Pressione di utilizzo	6,2 Bar
Consumo aria	1,3 l/ciclo
Ø interno tubo aria	8 mm
Capacità massima rivetti	Ø alluminio 4,8 mm

kg
1,83



1946AR

kit manutenzione per 1946A



1946B

rivettatrice

• Fornita assemblata per rivetti da 4,8 - 5,6 - 6,4 mm e con particolari intercambiabili per rivetti da 2,4 - 3,2 - 4,0 mm



Potenza di trazione	12000 N
Lunghezza della corsa	16 mm
Pressione di utilizzo	6,2 Bar
Consumo aria	1,6 l/ciclo
Ø interno tubo aria	10 mm
Capacità massima rivetti	Ø acciaio 6,4 mm

kg
2,05



1946BR

kit manutenzione per 1946B



1948

penna per incisioni



Pressione di utilizzo 6,2 Bar
Consumo aria medio 50 l/min

g
150



1948R

kit manutenzione per 1948



1948PR

punta in carburo di tungsteno di ricambio per 1948



1948PR



1949GP

pistola per gonfiaggio pneumatici corpo in ABS



1949GP



1949R/NIP

raccordo filettato 1/4" GAS per 1949GP



1949R/NIP



Beta

1995MQ/T

tappeto isolante

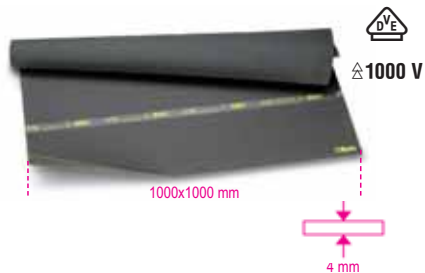

VDE 680/Part.1

1995MQ/T

1 019950030

1995MQ/G1 - G2

guanti isolanti, in lattice



EN 60903

	Gr.		
1995MQ/G1	9	1	019950010
1995MQ/G2	10	1	019950013

1995NS-N

nastro isolante nero



L m		
25	10	019950301

2005PA/D

porta attrezzi vuoto in Nylon, con cintura



2005PA/D

1 020050000

2005PA/S

porta attrezzi vuoto in Nylon, con cintura



2005PA/S

1 020050020

2007PM

porta martello in Nylon



2007PM

2 020070000

2008CR

cintura regolabile in Nylon



2008CR

2 020080000

2009N/BV

borsa per manutentori vuota in cuoio



530x190x210

1 020090200

2009I/1

borsa con assortimento di utensili per idraulica



2009I/1
(2009N/BV+5980I/1)

1 020090021

Beta Collection



2011/BV

borsa per elettricisti vuota in materiale sintetico, fianchi in ABS, con pannello portautensili rimovibile



mm
570x260x370 1 020110200

2011E

borse con assortimenti di utensili per elettrotecnica



2011E/1A 1 020110170

(2011/BV+5980E/1A)

2011E/2A 1 020110180

(2011/BV+5980E/2A)

2014N/VV

borsa portautensili a tre scomparti vuota in materiale sintetico con inserti in Nylon, con pannelli estraibili



mm
440x370x170 1 020140200

2014N/U5

borsa con 49 utensili per manutenzioni universali



2014N/U5 1 020140190

(2014N/VV+5915U5)

2029/VV

valigia portautensili in polipropilene ad alto spessore, profilata in alluminio, con doppia parete



mm
490x230x380 1 020290000

2029E

valigie con assortimenti di utensili per elettronica ed elettrotecnica



2029E/2A 1 020290110

(2029/VV+5980E/2A)

2029E/6 1 020290115

(2029/VV+5980E/6)

2029/RT

tracolla universale per borse e valigie



2029/RT 1 020290900

2031/VV

valigia portautensili in materiale plastico ABS, spessore 2,5 mm profilata in alluminio Anticorodal vuota



mm
440x350x200 1 020310010

2031E

valigie con assortimenti di utensili per elettronica



2031E/6 1 020310051

(2031/VV+5980E/6)

2031E/7 1 020310050

(2031/VV+5980E/7)



2031MQ/1

valigia in ABS con 44 utensili isolati



2031MQ/1
(2031/VV+5980MQ/1) 1 020310150

2032/VV

valigia portautensili in materiale plastico profilata in alluminio vuota



mm
450x390x170 1 020320010

2032E

valigie con assortimenti di utensili per elettronica ed elettrotecnica



2032E/1A
(2032/VV+5980E/1A) 1 020320071
2032E/7
(2032/VV+5980E/7) 1 020320061

2033N/VV

valigia portautensili vuota, in alluminio con fianchi in ABS



mm
500x380x200 1 020330200

2033E

valigie con assortimenti di utensili per elettronica ed elettrotecnica



2033E/2A
(2033N/VV+5980E/2A) 1 020330060
2033E/6
(2033N/VV+5980E/6) 1 020330040

2034/VV

valigia portautensili vuota, in alluminio



mm
470x380x170 1 020340200



2034

valigie con assortimenti di utensili per elettrotecnica e manutenzioni universali



2034E/1A 1 020340040

(2034/VV+5980E/1A)

2034/U5 1 020340060

(2034/VV+5915U5)

2036/TV

trolley portautensili vuoto, in polipropilene ad alto spessore, profilato in alluminio con doppia parete, manico telescopico e ruote con cuscinetti a sfera



mm 490x260x380 1 020360000

2036E

trolley con assortimenti di utensili per elettronica ed elettrotecnica



2036E/2A 1 020360022

(2036/TV+5980E/2A)

2036E/6 1 020360026

(2036/TV+5980E/6)

2040UC

valigia "Utility Case" con assortimento di 33 utensili in materiale plastico antiurto



2040UC 1 020400020

55 6x7-8x9-10x11-12x13-14x15-16x17 mm

96/SP9 \odot 1,5-2-2,5-3-4-5-6-8-10 mm

110 200 mm

1048 240 mm

1128BM 145 mm

1150 180 mm

1166 160 mm

1270 \bullet 3x75-3,5x100-4x125-5,5x150-6,5x150 mm

1272 \bullet PH0x60-PH1x80-PH2x100 mm

1370 300 g

1692B/3 3 m

1727M 315 mm

1728BM 300 mm

1770 140 mm

\equiv 405x365x80 mm - $\bar{\bar{h}}$ 4,5 kg

2050M

valigia antiurto con 27 utensili per nautica



2050M 1 020500011

34 150 mm

55 8x9-10x11-12x13-14x15-16x17
18x19 mm

55AS 3/8x7/16-1/2x9/16-5/8x11/16"

96 \odot 3-4-5-6 mm

110 200 mm

957 20,8 mm (13/16")

1044 240 mm

1084 160 mm

1150 180 mm

1270 \bullet 3x75-5,5x100 mm

1272 \bullet PH0x60-PH1x80 mm

1370 300 g

1490/1 \varnothing max 160 mm

1725CR 260 mm

1737 145 mm

\equiv 430x400x100 mm - $\bar{\bar{h}}$ 5,5 kg

 **Beta**



2051

valigia in polipropilene antiurto con assortimento di 55 utensili per nautica



1 020510100

2051

42 7 - 8 - 10 - 12 - 13 - 14 - 17 - 19 mm

55AS 3/8x7/16 - 1/2x9/16 - 5/8x11/16"

96/SP9 \varnothing 1,5+10 mm

110 200 mm

920A \varnothing 10 - 12 - 13 - 14 - 17 - 19 mm

920AS \varnothing 7/16 - 1/2 - 9/16 - 11/16 - 7/8"

920/22 255 mm - \square 1/2 - \blacksquare 1/2

920/25 \square 1/2 - \blacksquare 1/2

920/42 \blacksquare 1/2

920/55 \blacksquare 1/2

956C \square 1/2 - 16 - 20,8 mm

1048 240 mm

1084BM 160 mm

1128BMX 145 mm

1150BM 180 mm

1166BM 160 mm

1201 \bullet 3x75 - 4x100 - 5,5x150 - 6,5x150 mm

1202 \oplus PH1x80 - PH2x100 mm

1390 \varnothing 35 mm

1490/2 \varnothing max 240 mm

1737 145 mm

1778X

1995 WD40 400 ml

1995 NS-N 25m

\equiv 580x410x90 mm - \blacksquare 9 kg

2055M

valigia Home Bag con assortimento di 27 utensili



1 020550011

2055M

55 6x7-8x9-10x11-12x13 mm

96N/SP9 \varnothing 1,5-2-2,5-3-4-5-6-8-10 mm

417 4-5-6-8-9-10 mm

1151S 180 mm

1201 \bullet 3x75-4x100-5,5x150 mm

1202 \oplus PH1x80-PH2x100 mm

1370 300 g

1692B/3 3 m

\equiv 350x240x86 mm - \blacksquare 2,5 kg

2055L

valigia Home Bag con assortimento di 33 utensili



1 020550012

2055L

55 6x7-8x9-10x11-12x13 mm

96N/SP9 \varnothing 1,5-2-2,5-3-4-5-6-8-10 mm

417 4-5-6-8-9-10 mm

1048V 240 mm

1128BM 145 mm

1151S 180 mm

1201 \bullet 3x75-4x100-5,5x150-6,5x150 mm

1202 \oplus PH0x60-PH1x80-PH2x100 mm

1370 300 g

1692B/3 3 m

1755 30 cc

1771

\equiv 405x360x80 mm - \blacksquare 4,6 kg

2060/VV

valigia portautensili vuota, in resina ad alto spessore a tenuta stagna, galleggiante e impermeabile con valvola di rilascio a pressione manuale



1 020600101

mm
490x410x210

2080/VV

valigia organizer vuota



1 020800101

mm
400x340x70

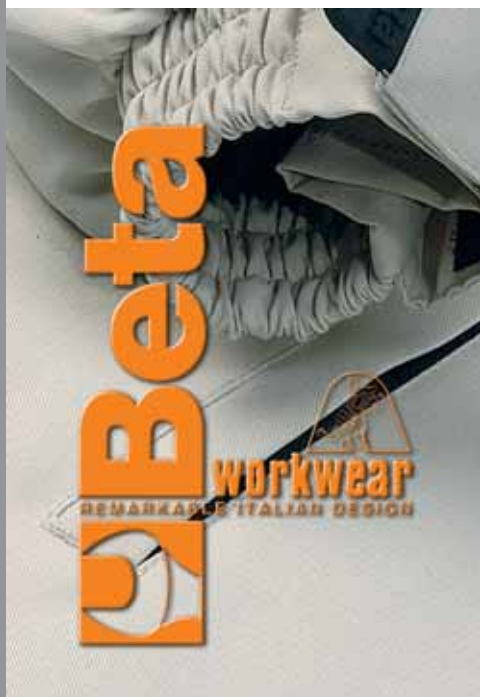

CONTENITORI E ASSORTIMENTI



Aluminium^{AL}
Innovation
Technology

 **Beta**
www.beta-tools.com

C10 - 2110

cestello portautensili in tessuto
con vaschetta portaminuterie



C10			1	021100000	
2110U2	(C10+5915U2)		1	021100052	230
2110U3	(C10+5915U3)		1	021100073	231
2110U/AS1	(C10+5915U/AS1)		1	021100075	232

≡ 520x220x250 mm

C13

baule portautensili con ruote,
in polipropilene ad alta resistenza



C13			1	021130000	
-----	--	--	---	-----------	--

≡ 870x410x350 mm

Beta

C15 - 2115

cestello in materiale plastico
con contenitore asportabile



C15		1	021150001	
2115U2	(C15+5915U2)	1	021150052	230
2115U3	(C15+5915U3)	1	021150173	231

≡ 480x260x260 mm

C15L - 2115L

cestello modello lungo in materiale plastico
con contenitore asportabile



C15L		1	021150002	
2115L/U2	(C15L+5915U2)	1	021150112	230
2115L/U3	(C15L+5915U3)	1	021150123	231

≡ 560x270x270 mm

CP16 - 2116

cestello in materiale plastico
con contenitore asportabile

- 2 cerniere in alluminio.
- maniglione pieghevole in alluminio.
- paracolpi in gomma.



CP16		1	021160500	
2116P/U2	(CP16+5915U2)	1	021160052	230
2116P/U3	(CP16+5915U3)	1	021160073	231
2116PU/AS1	(CP16+5915U/AS1)	1	021160075	232
2116PU/FR	(CP16+5915U/FR)	1	021160077	233

≡ 500x260x260 mm

CP17 - CP17L - 2117



cestello in acciaio inox e materiale plastico
con contenitore asportabile



CP17L
≡ 575x245x265 mm



CP17
≡ 500x200x220 mm



			
CP17	1	021170500	
2117P/U2 (CP17+5915U2)	1	021170052	230
2117P/U3 (CP17+5915U3)	1	021170073	231
CP17L	1	021170502	
2117PL/U2 (CP17L+5915U2)	1	021170112	230
2117PL/U3 (CP17L+5915U3)	1	021170123	231

C18 - 2118

cestello semplice
in lamiera



≡ 450x200x100 mm

			
C18	1	021180001	
2118/U2 (C18+5915U2)	1	021180052	230

C19 - 2119 - C19L - 2119L



cestello estendibile
a tre scomparti
in lamiera



C19L
≡ 550x200x160 mm





C19
≡ 450x200x160 mm

			
C19	1	021190001	
2119/U3 (C19+5915U3)	1	021190073	231
C19L	1	021190002	
2119L/U3 (C19L+5915U3)	1	021190093	231

C20 - C20L - 2120

cestello estendibile
a cinque scomparti
in lamiera

				
C20		1	021200001	
2120U3	(C20+5915U3)	1	021200073	231
2120U/AS1	(C20+5915U/AS1)	1	021200075	232
2120U/FR	(C20+5915U/FR)	1	021200077	233
C20L		1	021200002	
2120L/U3	(C20L+5915U3)	1	021200093	231
2120L/U/AS1	(C20L+5915U/AS1)	1	021200095	232
2120L/U/FR	(C20L+5915U/FR)	1	021200097	233



C20L
≡ 550x200x210 mm



C20
≡ 450x200x210 mm

C22B O - C22BL O

baule portautensili in lamiera



C22B O
≡ 720x320x310 mm



C22BL O
≡ 1010x410x400 mm

		
C22B O	1	022000150
C22BL O	1	022000170

C22W O - C22WL O



baule portautensili in lamiera, rivestito internamente per una maggiore protezione degli utensili



C22W O
≡ 690x300x360 mm



C22WL O
≡ 990x300x360 mm

		
C22W O	1	022000269
C22WL O	1	022000299

C22 - 2200

cassettera portatile con tre cassetti

Caratteristiche principali:

- Tre cassetti da 588x257 mm, montati su guide telescopiche a sfera: 2 cassetti altezza 50 mm 1 cassetto altezza 80 mm.
- Serratura centralizzata frontale.
- Maniglie laterali a scomparsa per il trasporto.



C22 O

C22 O	1	022000300	
2200 O/VI1 (C22 O+5902VI/1)	1	022000341	221
2200 O/MT1 (C22 O+5902MT/1)	1	022000362	238
2200 O/MT1AS (C22 O+5902MT1/AS)	1	022000343	239
C22 G	1	022000301	
2200 G/VI1 (C22 G+5902VI/1)	1	022000346	221
2200 G/MT1 (C22 G+5902MT/1)	1	022000367	238
2200 G/MT1AS (C22 G+5902MT1/AS)	1	022000348	239
C22 R	1	022000302	
2200 R/VI1 (C22 R+5902VI/1)	1	022000349	221
2200 R/MT1 (C22 R+5902MT/1)	1	022000369	238
2200 R/MT1AS (C22 R+5902MT1/AS)	1	022000339	239



C22 G



C22 R

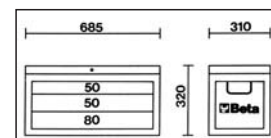

C23 - 2300

cassettera portatile con cinque cassetti

Caratteristiche principali:

- Cinque cassetti da 588x257 mm, montati su guide telescopiche a sfera: 3 cassetti altezza 50 mm 2 cassetti altezza 80 mm.
- Serratura centralizzata frontale.
- Maniglie laterali a scomparsa per il trasporto.



C23 O

C23 O	1	023000300	
2300 O/VI1 (C23 O+5902VI/1)	1	023000341	221
2300 O/MT1 (C23 O+5902MT/1)	1	023000362	238
2300 O/MT1AS (C23 O+5902MT1/AS)	1	023000333	239
C23 G	1	023000301	
2300 G/VI1 (C23 G+5902VI/1)	1	023000346	221
2300 G/MT1 (C23 G+5902MT/1)	1	023000367	238
2300 G/MT1AS (C23 G+5902MT1/AS)	1	023000338	239
C23 R	1	023000911	
2300 R/VI1 (C23 R+5902VI/1)	1	023000349	221
2300 R/MT1 (C23 R+5902MT/1)	1	023000369	238
2300 R/MT1AS (C23 R+5902MT1/AS)	1	023000339	239



C23 G



C23 R

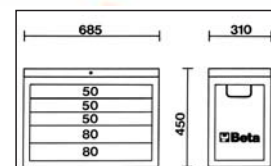

C23C - 2300C

cassettiera portatile con otto cassetti

Caratteristiche principali:

- Otto cassetti montati su guide telescopiche a sfera:
- 5 cassetti altezza 50 mm
- 2 cassetti altezza 80 mm
- 1 cassetto altezza 100 mm.
- Serratura centralizzata frontale.
- Maniglie laterali a scomparsa per il trasporto.



C23C O



C23C G



C23C R

C23C O	1	023000302	
2300C O/VI1 (C23C O+5902VI/1)	1	023000381	221
2300C O/MT1 (C23C O+5902MT/1)	1	023000382	238
C23C G	1	023000303	
2300C G/VI1 (C23C G+5902VI/1)	1	023000386	221
2300C G/MT1 (C23C G+5902MT/1)	1	023000387	238
C23C R	1	023000913	
2300C R/VI1 (C23C R+5902VI/1)	1	023000388	221
2300C R/MT1 (C23C R+5902MT/1)	1	023000389	238

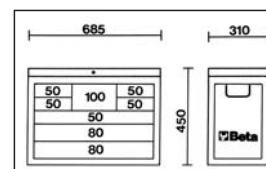

CD23N O

carrello Caddy

Caratteristiche principali:

- Piano di lavoro ricoperto in ABS sul quale sono collocabili a misura le cassettiere C22, C23, C23C.
- Quattro ruote Ø 125 mm:
- 2 fisse e 2 girevoli (una con freno).
- Portata massima 250 kg.



CD23N O			1	023000210
----------------	--	--	----------	------------------

Beta



C24 - 2400

cassettiera mobile con sette cassetti

Caratteristiche principali:

- Sette cassetti da 588x367 mm, montati su guide telescopiche a sfera:
- 1 cassetto altezza 50 mm
- 4 cassetti altezza 80 mm
- 2 cassetti altezza 160 mm.
- Piano dei cassetti protetto da tappetini di gomma espansa.
- Quattro ruote Ø 125 mm: 2 fisse e 2 girevoli (una con freno).
- Serratura centralizzata laterale.
- Capacità di carico statico: 800 kg.
- Piano di lavoro ricoperto in ABS sul quale è collocabile a misura una cassettera C22, C23 o C23C.
- Possibilità di applicazione del portacarta 2499PC e del portafiacconi 2499PF.



C24 O



C24 G



C24 R

C24 O		1	024000203	
2400 O/VI3	(C24 O+5904VI/3)	1	024000277	222
2400 O/VI4	(C24 O+5904VI/4)	1	024000267	223
2400 O/VG4	(C24 O+5904VG/4)	1	024000233	240
2400 O/VG5	(C24 O+5904VG/5)	1	024000253	241
C24 G		1	024000204	
2400 G/VI3	(C24 G+5904VI/3)	1	024000278	222
2400 G/VI4	(C24 G+5904VI/4)	1	024000268	223
2400 G/VG4	(C24 G+5904VG/4)	1	024000237	240
2400 G/VG5	(C24 G+5904VG/5)	1	024000258	241
C24 R		1	024000209	
2400 R/VI3	(C24 R+5904VI/3)	1	024000279	222
2400 R/VI4	(C24 R+5904VI/4)	1	024000269	223
2400 R/VG4	(C24 R+5904VG/4)	1	024000239	240
2400 R/VG5	(C24 R+5904VG/5)	1	024000259	241

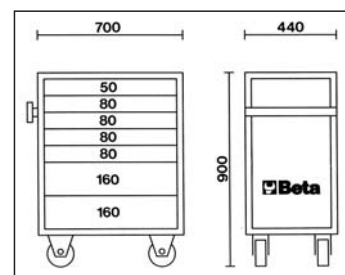
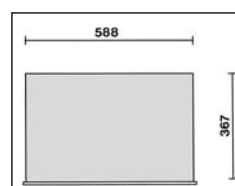

CX24 - 2400CX

cassettiera mobile con quattro cassetti

Caratteristiche principali:

- Quattro cassetti da 588x367 mm, montati su guide telescopiche a sfera:
- 1 cassetto altezza 50 mm
- 2 cassetti altezza 80 mm
- 1 cassetto altezza 160 mm
- 1 vano inferiore altezza 320 mm con antina a scomparsa.
- Piano dei cassetti protetto da tappetini di gomma espansa.
- Piano di lavoro ricoperto in ABS sul quale è collocabile a misura una cassetiera C22, C23 o C23C.
- Quattro ruote Ø 125 mm:
- 2 fisse e 2 girevoli (una con freno).
- Serratura centralizzata laterale.
- Capacità di carico statico: 800 kg.
- Piano di lavoro ricoperto in ABS sul quale è collocabile a misura una cassetiera C22, C23 o C23C.
- Possibilità di applicazione del portacarta 2499PC, e del portafalconi 2499PF.
- Pareti laterali forate per alloggiamento ganci portautensili.

800
kg



CX24 O



CX24 G



CX24 R

CX24 O	1	024000201	
2400CX O/VI3 (CX24 O+5904VI/3)	1	024000423	222
2400CX O/VG5 (CX24 O+5904VG/5)	1	024000426	241
CX24 G	1	024000202	
2400CX G/VI3 (CX24 G+5904VI/3)	1	024000424	222
2400CX G/VG5 (CX24 G+5904VG/5)	1	024000427	241
CX24 R	1	024000082	
2400CX R/VI3 (CX24 R+5904VI/3)	1	024000425	222
2400CX R/VG5 (CX24 R+5904VG/5)	1	024000428	241

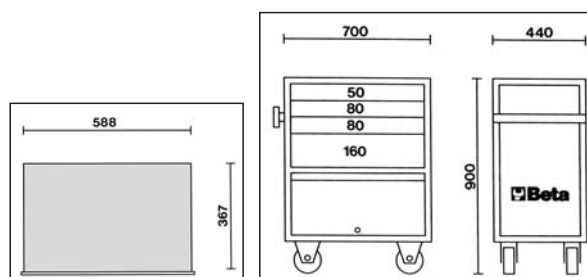

CX24/W - 2400W

cassettiera mobile con cinque cassetti

Caratteristiche principali:

- Cinque cassetti da 588x367 mm, montati su guide telescopiche a sfera:
- 1 cassetto altezza 50 mm
- 2 cassetti altezza 80 mm
- 1 cassetto altezza 160 mm
- 1 cassetto altezza 320 mm.
- Piano dei cassetti protetto da tappetini di gomma espansa.
- Quattro ruote Ø 125 mm:
- 2 fisse e 2 girevoli (una con freno).
- Serratura centralizzata laterale.
- Capacità di carico statico: 800 kg.
- Piano di lavoro ricoperto in ABS sul quale è collocabile a misura una cassetiera C22, C23 o C23C.
- Possibilità di applicazione del portacarta 2499PC, e del portafalconi 2499PF.
- Pareti laterali forate per alloggiamento ganci portautensili.

800
kg



CX24 O/W



CX24 G/W



CX24 R/W

CX24 O/W	1	024000085	
2400W O/VG4 (CX24W O+5904VG/4)	1	024000431	240
2400W O/VG5 (CX24W O+5904VG/5)	1	024000435	241
CX24 G/W	1	024000087	
2400W G/VG4 (CX24W G+5904VG/4)	1	024000432	240
2400W G/VG5 (CX24W G+5904VG/5)	1	024000436	241
CX24 R/W	1	024000086	
2400W R/VG4 (CX24W R+5904VG/4)	1	024000433	240
2400W R/VG5 (CX24W R+5904VG/5)	1	024000437	241

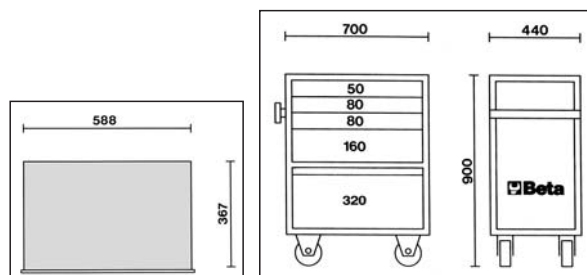

C24H6 - 2400H6

cassettiera mobile
con sei cassetti

Caratteristiche principali:

- Sei cassetti da 588x367 mm, montati su guide telescopiche a sfera:
- 4 cassetti altezza 80 mm
- 1 cassetto altezza 160 mm
- 1 cassetto altezza 210 mm.
- Piano dei cassetti protetto da tappetini di gomma espansa.
- Quattro ruote Ø 125 mm: 2 fisse e 2 girevoli (una con freno).
- Serratura centralizzata laterale.
- Capacità di carico statico: 800 kg.
- Piano di lavoro in alluminio antiscivolo.
- 1 portafiaccone laterale
- Possibilità di applicazione del portacarta 2499PC.

800
kg



C24H6 O



C24H6 G



C24H6 R

C24H6 O	1	024000235	
2400H6 O/VI3 (C24H6 O+5904VI/3)	1	024000642	222
2400H6 O/VG4 (C24H6 O+5904VG/4)	1	024000652	240
2400H6 O/VG7 (C24H6 O+5904VG/7)	1	024000682	243
C24H6 G	1	024000236	
2400H6 G/VI3 (C24H6 G+5904VI/3)	1	024000643	222
2400H6 G/VG4 (C24H6 G+5904VG/4)	1	024000653	240
2400H6 G/VG7 (C24H6 G+5904VG/7)	1	024000683	243
C24H6 R	1	024000238	
2400H6 R/VI3 (C24H6 R+5904VI/3)	1	024000644	222
2400H6 R/VG4 (C24H6 R+5904VG/4)	1	024000654	240
2400H6 R/VG7 (C24H6 R+5904VG/7)	1	024000684	243

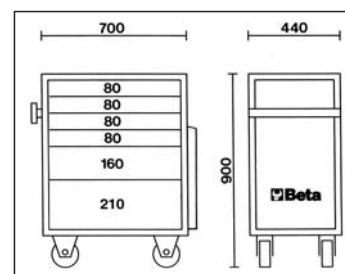
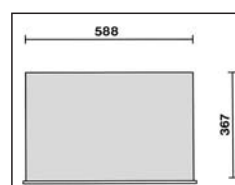

Beta

C24H - 2400H

cassettiera mobile
con sette cassetti

Caratteristiche principali:

- Sette cassetti da 588x367 mm, montati su guide telescopiche a sfera:
- 1 cassetto altezza 50 mm
- 4 cassetti altezza 80 mm
- 2 cassetti altezza 160 mm.
- Piano dei cassetti protetto da tappetini di gomma espansa.
- Quattro ruote Ø 125 mm:
- 2 fisse e 2 girevoli (una con freno).
- Serratura centralizzata laterale.
- Capacità di carico statico: 800 kg.
- Piano di lavoro in alluminio antiscivolo.
- 1 portaflacone laterale (agganciabile su entrambi i lati).
- Possibilità di applicazione del portacarta 2499PC.



C24H O



C24H G



C24H R

C24H O	1	024000205	
2400H O/VI4 (C24H O+5904VI/4)	1	024000566	223
2400H O/VG6 (C24H O+5904VG/6)	1	024000576	242
2400 H O/VG2 (C24H O+5909VG/2)	1	024000586	247
C24H G	1	024000206	
2400H G/VI4 (C24H G+5904VI/4)	1	024000568	223
2400H G/VG6 (C24H G+5904VG/6)	1	024000578	242
2400 H G/VG2 (C24H G+5909VG/2)	1	024000588	247
C24H R	1	024000208	
2400H R/VI4 (C24H R+5904VI/4)	1	024000569	223
2400H R/VG6 (C24H R+5904VG/6)	1	024000579	242
2400 H R/VG2 (C24H R+5909VG/2)	1	024000589	247

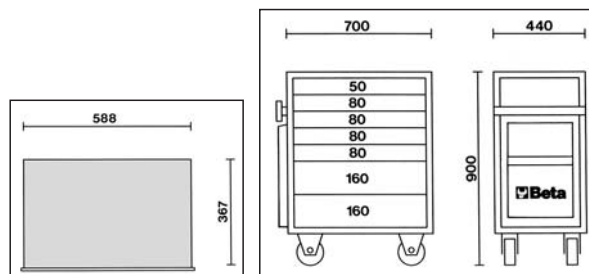

C24/PM

portaminuterie

- Abbinabile alle cassettiere serie C24, CX24, CX24/W, C24H6 e C24H



C24/PM			1	024000116
---------------	--	--	---	-----------

C24/PU

pannello portautensili.

- Abbinabile alle cassettiere serie C24, CX24, CX24/W, C24H6 e C24H



C24/PU			1	024000119
---------------	--	--	---	-----------

2499PF

portaflaconi

• Abbinabile alle cassettiere serie CX24, CX24W, C24, C38 e carrello CX52.

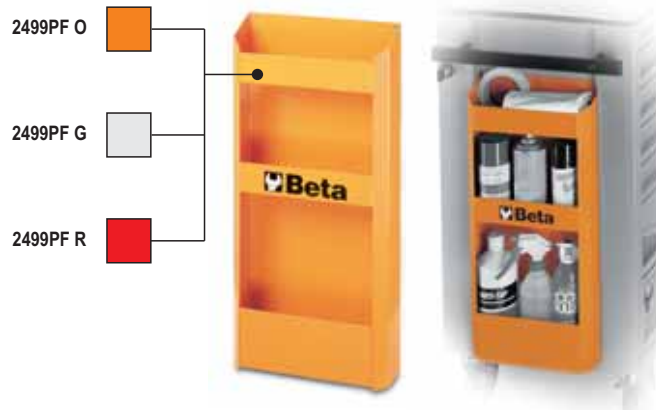

2499PF O	1	024990210
2499PF G	1	024990219
2499PF R	1	024990230

2499PF/M

portaflaconi universale magnetico



2499PF/M	1	024990050
----------	---	-----------

2499PP/M

supporto magnetico per avvitatore pneumatico



2499PP/M	1	024990060
----------	---	-----------

2499PC

portacarta per rotoli preforati

• Abbinabile a tutti i carrelli Tank C25, NewTeam CX52 e alle cassettiere serie C24, CX24, CX24W, C24H6, C24H, C24XL e C38.



2499PC	1	024990090
--------	---	-----------

C24XL - 2400XL

cassettiera mobile
con sette cassetti
e ripiani laterali

Caratteristiche principali:

- Sette cassetti da 588x367 mm, montati su guide telescopiche: 6 cassetti altezza 80 mm 1 cassetto altezza 160 mm.
- Piano dei cassetti protetto da tappetini di gomma espansa.
- Quattro ruote Ø 125 mm: 2 fisse e 2 girevoli (una con freno).
- Serratura centralizzata frontale.
- Capacità di carico statico: 800 kg.
- Piano di lavoro in legno multistrato.
- Doppio vano posteriore portafiacconi.
- Possibilità di applicazione del portacarta 2499PC.

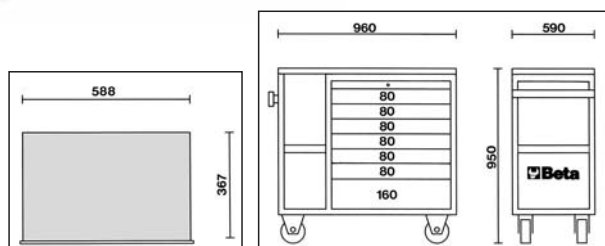

C24XL		1	024000005	
2400XL/VI4	(C24XL+5904VI/4)	1	024000145	223
2400XL/VG5	(C24XL+5904VG/5)	1	024000155	241

C25 - 2500

carrello Tank con mensola

Caratteristiche principali:

- Coperchio di chiusura ribaltabile.
- 1 cassetto scorrevole.
- Piano di alloggiamento utensili protetto da tappetini di gomma espansa.
- Piani di servizio protetti con tappetini in gomma antioil e antibenzina.
- Quattro ruote Ø 100 mm: 2 fisse e 2 girevoli (una con freno).
- Serratura centralizzata frontale.
- Termoformato vuoto per bussole e accessori da 1/2".
- Possibilità di applicazione del portacarta 2499PC.

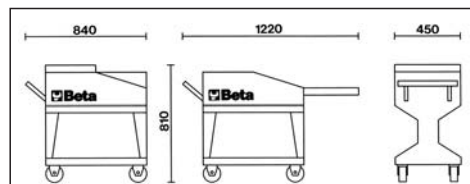

C25		1	025000001	
2500/VI1	(C25+5902VI/1)	1	025000341	221
2500/VG0	(C25+5905VG/0)	1	025000071	244
2500/VG4	(C25+5905VG/4)	1	025000048	244
2500/VCR1	(C25+5905VCR/1)	1	025000047	245

Beta

C28N - 2800N

carrello SuperTank con undici cassetti

Caratteristiche principali:

- Undici cassetti da 588x367 mm, montati su guide telescopiche.
- Cinque cassetti laterali di cui:
 - 1 cassetto altezza 50 mm
 - 3 cassetti altezza 80 mm
 - 1 cassetto altezza 160 mm.
- Sei cassetti frontali di cui:
 - 1 cassetto altezza 50 mm
 - 5 cassetti altezza 80 mm.
- Piano dei cassetti protetto da tappetini di gomma espansa.
- Quattro ruote in Adiprene Ø 150 mm: 2 fisse e 2 girevoli con freno.
- 2 serrature centralizzate.
- Piano di lavoro in legno multistrato con fori per la collocazione di una morsa (1599 M100 da ordinare separatamente).
- Vano laterale con antina di chiusura a scomparsa con serratura.
- Vano passante altezza 170 mm con base ricoperta in materiale plastico.
- Portaminuterie in materiale plastico integrato.
- Capacità di carico statico: kg 1200.



C28N O



C28N G



C28N R

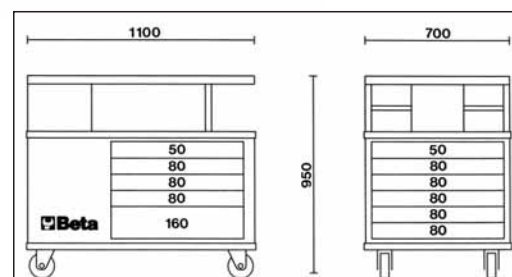
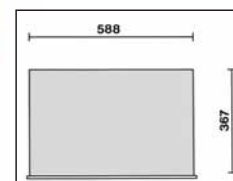

Model	Accessories	Quantity	Part Number	Price
C28N O		1	028000004	
2800N O/VI2	(C28N+5908/VI2)	1	028000252	224
2800N O/VI3	(C28N O+5908VI/3)	1	028000255	225
2800N O/VG4	(C28N O+5908VG/4)	1	028000257	245
2800N O/VG5	(C28N O+5908VG/5)	1	028000258	246
C28N G		1	028000006	
2800N G/VI3	(C28N G+5908VI/3)	1	028000265	225
2800N G/VG4	(C28N G+5908VG/4)	1	028000267	245
2800N G/VG5	(C28N G+5908VG/5)	1	028000268	246
C28N R		1	028000007	
2800N G/VI2	(C28N+5908/VI2)	1	028000262	224
2800N R/VI2	(C28N+5908/VI2)	1	028000263	224
2800N R/VI3	(C28N R+5908VI/3)	1	028000269	225
2800N R/VG4	(C28N R+5908VG/4)	1	028000270	245
2800N R/VG5	(C28N R+5908VG/5)	1	028000278	246

C28T - 2800T

carrello SuperTank con piano di lavoro e dieci cassetti

Caratteristiche principali:

- Dieci cassetti da 588x367 mm, montati su guide telescopiche a sfera.
- Apertura automatica dei cassetti "One-Touch".
- Cinque cassetti laterali di cui:
 - 4 cassetti altezza 80 mm
 - 1 cassetto altezza 160 mm.
- Cinque cassetti frontali di cui:
 - 4 cassetti altezza 80 mm
 - 1 cassetto altezza 160 mm.
- Piano dei cassetti protetto da tappetini di gomma espansa.
- Quattro ruote in Adiprene Ø 150 mm: 2 fisse e 2 girevoli con freno.
- 2 serrature di sicurezza centralizzate.
- 3 cassettoni frontali portaoggetti.
- Piano di lavoro in legno multistrato con fori per la collocazione di una morsa (1599 M125 o M150 da ordinare separatamente).
- Vano integrato portaminuterie.
- Vano laterale con antina di chiusura a scomparsa con serratura.
- Portaflaconi integrati.
- Vano passante altezza 170 mm con base ricoperta in materiale plastico.
- Capacità di carico statico: kg 1200.



C28T O



C28T G



C28T R

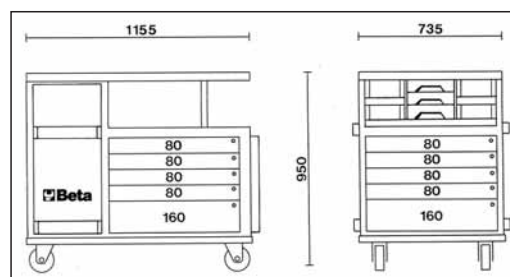
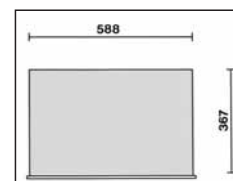

Model	Accessories	Qty	Code	Price
C28T O		1	028000013	
2800T O/VI2	(C28T+5908/VI2)	1	028000272	224
2800T O/VI3	(C28T O+5908VI/3)	1	028000275	225
2800T O/VG6	(C28T O+5904VG/6)	1	028000295	242
C28T G		1	028000016	
2800T G/VI2	(C28T+5908/VI2)	1	028000282	224
2800T G/VI3	(C28T G+5908VI/3)	1	028000285	225
2800T G/VG6	(C28T G+5904VG/6)	1	028000297	242
C28T R		1	028000014	
2800T R/VI2	(C28T+5908/VI2)	1	028000292	224
2800T R/VI3	(C28T R+5908VI/3)	1	028000289	225
2800T R/VG6	(C28T R+5904VG/6)	1	028000299	242



C30 - 3000

posto di lavoro mobile MaxiTank

Caratteristiche principali:

- Cassetti montati su guide telescopiche con scorrimento su cuscinetti per sopportare pesi rilevanti.
- Due cassetti posteriori con dispositivo di bloccaggio da 670x500x140 mm.
- Sei cassetti anteriori di cui:
 - 4 cassetti da 600x250x70 mm
 - 2 cassetti da 600x250x140 mm.
- Doppia chiusura laterale per cassetti ed antine.
- Un martinetto idraulico consente, senza sforzo, il sollevamento della parte anteriore e quindi una traslazione agevole.
- Ruote in Adiprene montate su cuscinetti a sfera di cui:
 - 2 girevoli, anteriori, Ø 150 mm
 - 2 fisse, posteriori, Ø 170 mm.
- Piano dei cassetti protetto da tappetini di gomma espansa.
- Piano di lavoro in legno multistrato 800x500 mm con tre fori per la collocazione di una morsa tipo 1599 M125/M150/M165 (da ordinare separatamente).
- Piano di lavoro ricoperto in gomma antiolio 800x800 mm con foro di scarico per la raccolta di liquidi in un piccolo serbatoio.
- Vano passante 720x250x1300 mm con piano ricoperto in PVC, chiuso lateralmente da antine a scomparsa.
- Capacità di carico statico: kg 1200.



			
C30	1	030000001	
3000/VI3 (C30+5908VI/3)	1	030000051	225
3000/VI1 (C30+5910/VI1)	1	030000063	227
3000/VG1 (C30+5910VG/1)	1	030000044	248

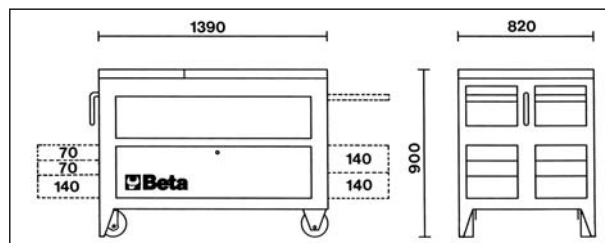

 **Beta**



C36/5 - 3600

cassettiera mobile "EVOLUTION" con cinque cassetti

Caratteristiche principali:

- Cinque cassetti da 588x367 mm, montati su guide telescopiche a sfera:
- 3 cassetti altezza 70 mm
- 1 cassetto altezza 210 mm
- 1 cassetto altezza 290 mm.
- Piano dei cassetti protetto da tappetini di gomma espansa.
- Quattro ruote Ø 125 mm:
- 2 fisse e 2 girevoli (una con freno).
- Serratura di sicurezza centralizzata frontale.
- Sistema di apertura posizionato su tutta la lunghezza del cassetto.
- Capacità di carico statico: 1000 kg.
- Piano di lavoro ricoperto in ABS.
- Portaforconi laterali integrati.
- Portaminuterie laterale integrato.
- Dispositivo portacarta integrato.
- Paracolpi in materiale plastico.
- Maniglia ricoperta da spugna anticivolo.



C36 O/5



C36 G/5



C36 R/5

C36/O-5	1	036000005	
3600 O-5/VI3 (C36 O/5+5904VI/3)	1	036000111	222
3600 O-5/VG4 (C36 O/5+5904VG/4)	1	036000121	240
3600 O-5/VG7 (C36 O/5+5904VG/7)	1	036000191	243
C36/G-5	1	036000025	
3600 G-5/VI3 (C36 G/5+5904VI/3)	1	036000112	222
3600 G-5/VG4 (C36 G/5+5904VG/4)	1	036000122	240
3600 G-5/VG7 (C36 G/5+5904VG/7)	1	036000192	243
C36/R-5	1	036000015	
3600 R-5/VI3 (C36 R/5+5904VI/3)	1	036000113	222
3600 R-5/VG4 (C36 R/5+5904VG/4)	1	036000123	240
3600 R-5/VG7 (C36 R/5+5904VG/7)	1	036000193	243

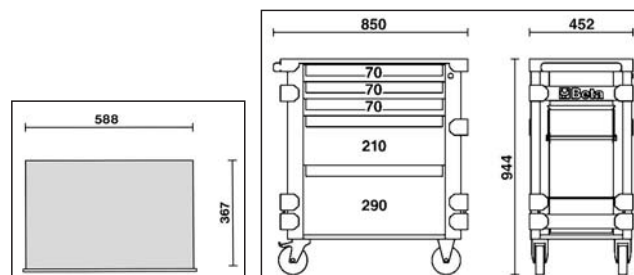

Beta



C36/7 - 3600

cassettiera mobile "EVOLUTION"
con sette cassetti

Caratteristiche principali:

- Sette cassetti da 588x367 mm, montati su guide telescopiche a sfera:
- 5 cassetti altezza 70 mm
- 1 cassetto altezza 140 mm
- 1 cassetto altezza 210 mm.
- Piano dei cassetti protetto da tappetini di gomma espansa.
- Quattro ruote Ø 125 mm:
- 2 fisse e 2 girevoli (una con freno).
- Serratura di sicurezza centralizzata frontale.
- Sistema di apertura posizionato su tutta la lunghezza del cassetto.
- Capacità di carico statico: 1000 kg.
- Piano di lavoro ricoperto in ABS.
- Portaflaconi laterali integrati.
- Portaminuterie laterale integrato.
- Dispositivo portacarta integrato.
- Paracolpi in materiale plastico.
- Maniglia ricoperta da spugna antiscivolo.

1000
kg



C36 O/7

C36/O-7	1	036000007	
3600 O-7/VI3 (C36 O/7+5904VI/3)	1	036000114	222
3600 O-7/VI4 (C36 O/7+5904VI/4)	1	036000164	223
3600 O-7/VG5 (C36 O/7+5904VG/5)	1	036000134	241
3600 O-7/VG6 (C36 O/7+5904VG/6)	1	036000184	242
3600 O-7/VG7 (C36 O/7+5904VG/7)	1	036000194	243
3600 O-7/VG2 (C36 O/7+5909VG/2)	1	036000174	247
C36/G-7	1	036000027	
3600 G-7/VI3 (C36 G/7+5904VI/3)	1	036000115	222
3600 G-7/VI4 (C36 G/7+5904VI/4)	1	036000165	223
3600 G-7/VG5 (C36 G/7+5904VG/5)	1	036000135	241
3600 G-7/VG6 (C36 G/7+5904VG/6)	1	036000185	242
3600 G-7/VG7 (C36 G/7+5904VG/7)	1	036000195	243
3600 G-7/VG2 (C36 G/7+5909VG/2)	1	036000175	247
C36/R-7	1	036000017	
3600 R-7/VI3 (C36 R/7+5904VI/3)	1	036000116	222
3600 R-7/VI4 (C36 R/7+5904VI/4)	1	036000166	223
3600 R-7/VG5 (C36 R/7+5904VG/5)	1	036000136	241
3600 R-7/VG6 (C36 R/7+5904VG/6)	1	036000186	242
3600 R-7/VG7 (C36 R/7+5904VG/7)	1	036000196	243
3600 R-7/VG2 (C36 R/7+5909VG/2)	1	036000176	247



C36 G/7



C36 R/7

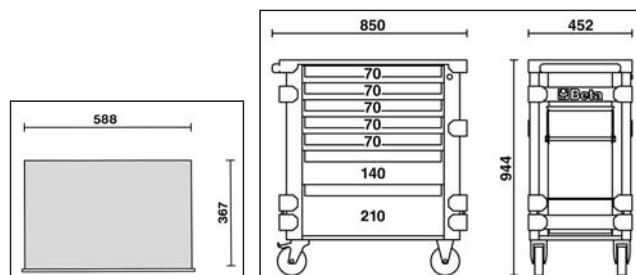

C36/PLA

piano di lavoro in alluminio antiscivolo
per le cassette C36/5 e C36/7



C36/PLA	1	036000105	

C38 - 3800

cassettiera mobile con undici cassetti

Caratteristiche principali:

- Undici cassetti montati su guide telescopiche a sfera:
 - 1 cassetto 937x410x122 mm
 - 3 cassetti 570x410x74 mm
 - 2 cassetti 570x410x153 mm
 - 3 cassetti 313x410x74 mm
 - 2 cassetti 313x410x153 mm.
- Piano dei cassetti protetto da tappetini di gomma espansa.
- Capacità di carico statico: 1200 kg.
- 4 ruote ad alta portata Ø 125 mm:
 - 2 fisse e 2 girevoli (entrambe con freno a leva).
- Serratura centralizzata frontale.
- Piano di lavoro di lamiera ricoperto da tappetino in gomma.
- Possibilità di applicazione del portacarta 2499PC e del portafaconi 2499PF.



C38 O



C38 G



C38 R

C38 O		1	038000001	
3800 O/U1	(C38 O+5938U/1)	1	038000041	233
C38 G		1	038000003	
3800 G/U1	(C38 G+5938U/1)	1	038000043	233
C38 R		1	038000002	
3800 R/U1	(C38 R+5938U/1)	1	038000042	233

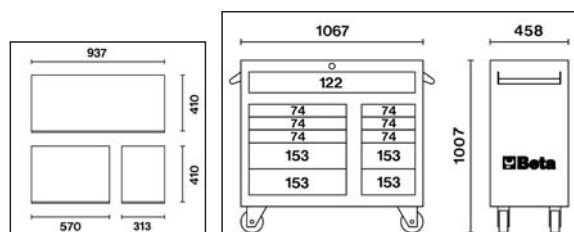

Beta



C38A - 3800A

cassettiera mobile
con sei cassetti e un vano con scaffale chiudibile con antina

Caratteristiche principali:

- Sei cassetti montati su guide telescopiche a sfera:
 - 1 cassetto 937x410x122 mm
 - 3 cassetti 570x410x74 mm
 - 2 cassetti 570x410x153 mm.
- Scaffale interno regolabile in altezza.
- Tasca portadocumenti posizionata all'interno dell'antina.
- Piano dei cassetti protetto da tappetini di gomma espansa.
- Capacità di carico statico: 1200 kg.
- 4 ruote ad alta portata Ø 125 mm:
 - 2 fisse e 2 girevoli (entrambe con freno a leva).
- Serratura centralizzata frontale.
- Piano di lavoro di lamiera ricoperto da tappetino in gomma.
- Possibilità di applicazione del portacarta 2499PC e del portafilaconi 2499PF.

1200
kg



C38A O



C38A G



C38A R

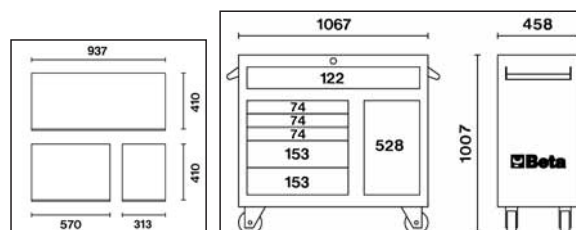

C38A O	1	038000301
C38A G	1	038000303
C38A R	1	038000302

C38L

cassettiera laterale
con sette cassetti

Caratteristiche principali:

- Sette cassetti da 410x313 mm, montati su guide telescopiche a sfera:
 - 5 cassetti altezza 74 mm
 - 2 cassetti altezza 153 mm.
- Piano dei cassetti protetto da tappetini di gomma espansa.
- Serratura di sicurezza centralizzata frontale.
- Piano di lavoro in alluminio antiscivolo.
- Agganciabile su entrambi i lati della C38 e C38A.



C38L O



C38L G



C38L R

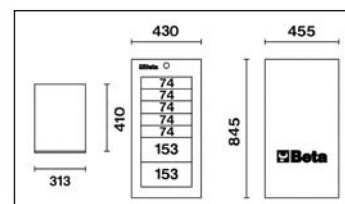

C38L O	1	038000081
C38L G	1	038000083
C38L R	1	038000082

C38T

cassettiera top
con otto cassetti e vano portautensili

Caratteristiche principali:

- Otto cassetti montati su guide telescopiche a sfera:
- 3 cassetti 570x410x74 mm
- 1 cassetto 570x410x153 mm
- 3 cassetti 313x410x74 mm
- 1 cassetto 313x410x153 mm.
- Vano portautensili.
- Piano dei cassetti protetto da tappetini di gomma espansa.
- Serratura di sicurezza centralizzata frontale.
- Collocabile sulla cassettiera C38 e C38A.



C38T O



C38T G



C38T R

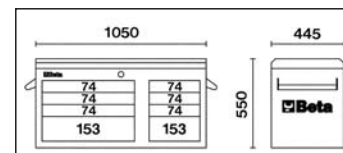
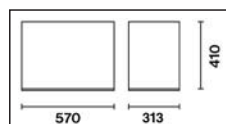

C38T O	1	038000091
C38T G	1	038000093
C38T R	1	038000092

C38C

cassettiera mobile con trentatré cassetti
composta da:

- 1 cassettiera mobile C38
- 2 cassette laterali C38L
- 1 cassettiera top C38T

C38C O



C38C G



C38C R

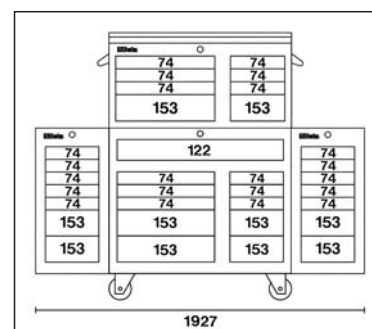
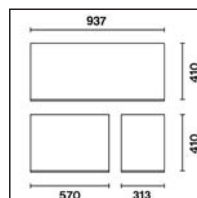

C38C O	1	038000201
C38C G	1	038000203
C38C R	1	038000202

C39 - 3900

cassettiera mobile con sette cassetti

Caratteristiche principali:

- Sette cassetti da 588x367 mm, montati su guide telescopiche a sfera:
- 5 cassetti altezza 70 mm
- 1 cassetto altezza 140 mm
- 1 cassetto altezza 210 mm
- Piano dei cassetti protetto da tappetini di gomma espansa.
- Quattro ruote Ø 125 mm:
- 2 fisse e 2 girevoli (una con freno).
- Serratura di sicurezza centralizzata frontale.
- Sistema di apertura posizionato su tutta la lunghezza del cassetto.
- Capacità di carico statico: 1200 kg.
- Piano di lavoro termoplastico.
- Portaflaconi laterali e posteriori integrati.
- Portacarta integrato.
- Montanti e frontalino del cassetto in alluminio.



C39 O



C39 G



C39 R



C39 O		1	039000001	
3900 O/VI4	(C39 O+5904VI/4)	1	039000061	223
3900 O/VI1	(C39 O+5909VI/1)	1	039000051	226
3900 O/VG6	(C39 O+5904VG/6)	1	039000081	242
3900 O/VG7	(C39 O+5904VG/7)	1	039000091	243
3900 O/VG2	(C39 O+5909VG/2)	1	039000071	247
C39 G		1	039000002	
3900 G/VI4	(C39 G+5904VI/4)	1	039000062	223
3900 G/VI1	(C39 G+5909VI/1)	1	039000052	226
3900 G/VG6	(C39 G+5904VG/6)	1	039000082	242
3900 G/VG7	(C39 G+5904VG/7)	1	039000092	243
3900 G/VG2	(C39 G+5909VG/2)	1	039000072	247
C39 R		1	039000003	
3900 R/VI4	(C39 R+5904VI/4)	1	039000063	223
3900 R/VI1	(C39 R+5909VI/1)	1	039000053	226
3900 R/VG6	(C39 R+5904VG/6)	1	039000083	242
3900 R/VG7	(C39 R+5904VG/7)	1	039000093	243
3900 R/VG2	(C39 R+5909VG/2)	1	039000073	247

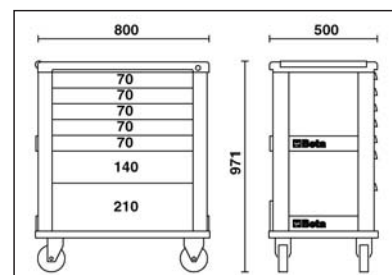
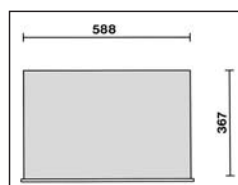

C39/PM

pannello portaminuterie per C39



C39/PM



1



039000530

C39/PU

pannello portautensili per C39



C39/PU



1



039000529

C41S - 4100S

trolley portautensili
a due moduli sovrapponibili

Caratteristiche principali:

- Struttura in lamiera e piani in materiale plastico: grande robustezza e peso ridotto.
- 2 moduli separabili:
 - 1 cestello superiore,
 - 1 modulo con 1 cassetto altezza 95 mm e 1 cassetto altezza 295 mm.
- Ruote di grosso diametro (160 mm), integrate nella struttura per facilitare il trasporto anche su gradini.
- Serratura centralizzata laterale per la chiusura dei 2 cassettei del modulo inferiore.
- Cassetti montati su guide telescopiche a sfera con doppio gancio di chiusura.
- Impugnatura con manico telescopico in alluminio.
- Portaminuterie integrato nel cestello superiore.

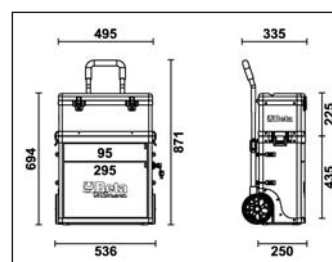
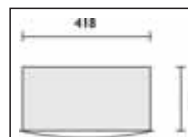

C41S



1

041000001

4100S/U3

(C41S+5915U3)

1

041000051

231

4100S/M1

(C41S+5940/M1)

1

041000031

249

C41H - 4100H

trolley portautensili
a due moduli sovrapponibili

Caratteristiche principali:

- Struttura in lamiera e piani in materiale plastico: grande robustezza e peso ridotto.
- 2 moduli separabili:
 - 1 cestello superiore,
 - 1 modulo con 2 cassetti altezza 95 mm,
 - 1 cassetta estraibile in materiale plastico altezza 66 mm e 1 cassetto altezza 295 mm.
- Ruote di grosso diametro (160 mm), integrate nella struttura per facilitare il trasporto anche su gradini.
- Serratura centralizzata laterale per la chiusura dei cassetti del modulo inferiore.
- Cassetti montati su guide telescopiche a sfera con doppio gancio di chiusura.
- Impugnatura con manico telescopico in alluminio.
- Portaminuterie integrato nel cestello superiore.



C41H		1	041000002	
4100H/U3	(C41H+5915U3)	1	041000061	231
4100H/M1	(C41H+5940/M1)	1	041000041	249

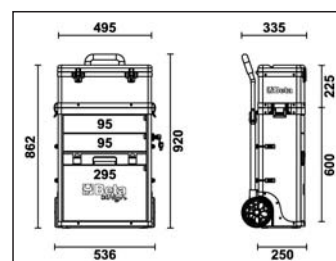
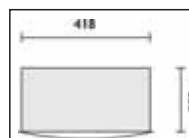

C41MS

modulo superiore con portaminuterie integrato



C41MS		1	041000904	
-------	--	---	-----------	--

C41H/CE

cassetta portautensili con separatori estraibili per minuterie,
in materiale plastico



C41H/CE		1	041000916	
---------	--	---	-----------	--

CX52

carrello NewTeam

Caratteristiche principali:

- Piano superiore dimensionato per l'alloggiamento degli armadietti NewCargo, ancorabili mediante due viti.
- Piano superiore ricoperto in ABS.
- Ripiani ricoperti in materiale plastico.
- Quattro ruote Ø 125 mm: 2 fisse e 2 girevoli (una con freno).
- Possibilità di applicazione del portacarta 2499PC e del portafaconi 2499PF.



CX52 O



CX52 G



CX52 R

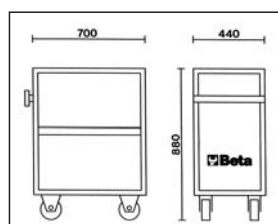

CX52 O	1	052000001
CX52 G	1	052000002
CX52 R	1	052000003

C53 - 5300

armadietti CargoEvolution

Sono realizzati sulla base di accurate ricerche presso qualificati utilizzatori professionali ed offrono le soluzioni ideali per operare in modo confortevole e razionale.

L'apertura dei pannelli forati delle due antine permette lo sfruttamento anche della loro superficie interna.

Caratteristiche principali:

- 1 cassetto montato su guide telescopiche.
- Possibilità di modificare facilmente la disposizione degli utensili in funzione delle proprie esigenze.
- Posizionamento a parete per mezzo di due asole situate posteriormente, oppure collocabile su carrello Team C50, con ancoraggio tramite due viti.
- Serratura per chiusura contemporanea di antine e cassetto.
- Termoformato vuoto per bussole e accessori da 1/2".
- Le versioni VI e VG differiscono per il diverso allestimento dei supporti portautensili e sono forniti con ganci e supporti (senza utensili).



C53



5300

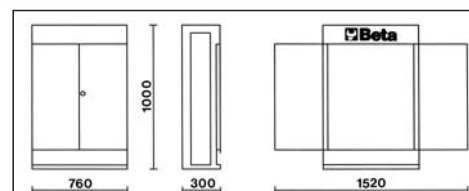

C53	1	053000001	
C53VI	1	053000090	
5300VI/2	(C53VI+5953VI/2)	1	053000031 228
C53VG	1	053000095	
5300VG2	(C53VG+5953VG/2)	1	053000041 249

C54 - 5400

armadietti NewCargo

Caratteristiche simili all'articolo C53.

- Collocabile su carrello CX52, con ancoraggio tramite due viti.
- Termoformato vuoto per bussole e accessori da 1/2".
- Antine utilizzabili solo da un lato.
- Le versioni VI e VG differiscono per il diverso allestimento dei supporti portautensili e sono forniti con ganci e supporti (senza utensili).



5400 O



C54 O



C54 G



C54 R

C54 O	1	054000001	
C54VI O	1	054000090	
5400 O/VI2 (C54VI O+5954VI/2)	1	054000070	228
C54VG O	1	054000095	
5400 O/VG2 (C54VG O+5954VG/2)	1	054000080	250
C54 G	1	054000002	
C54VI G	1	054000092	
5400 G/VI2 (C54VI G+5954VI/2)	1	054000072	228
C54VG G	1	054000097	
5400 G/VG2 (C54VG G+5954VG/2)	1	054000082	250
C54 R	1	054000003	
C54VI R	1	054000093	
5400 R/VI2 (C54VI R+5954VI/2)	1	054000074	228
C54VG R	1	054000098	
5400 R/VG2 (C54VG R+5954VG/2)	1	054000084	250

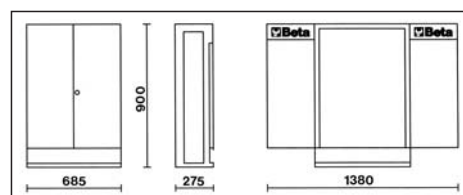

Beta



C57A - 5700A

banco da lavoro MasterCargo

• Modello con parete portautensili (C57P) e una cassetiera (C57P) e una cassetiera.

Cassetiera formata da cinque cassetti da 600x370 mm di cui 3 altezza 100 mm e 2 altezza 175 mm montati su guide telescopiche con scorrimento su cuscinetti per sopportare pesi rilevanti. Serratura centralizzata.

Parete portautensili anche appendibile mediante asole.

Tapparella in alluminio, manovrabile verticalmente, con serratura.

Tre pannelli forati amovibili per il sostegno degli utensili.

Piano di lavoro in legno multistrato, rivestito in laminato plastico con tre fori per la collocazione di una morsa 1599 M125/M150/M165, da ordinare separatamente.



C57A O



C57A G



5700A O



C57A R

C57A O	1	057000001	
5700A O/VI2 (C57A O+5957VI/2)	1	057000071	229
5700A O/VG2 (C57A O+5957VG/2)	1	057000072	251
C57A G	1	057000201	
5700A G/VI2 (C57A G+5957VI/2)	1	057000271	229
5700A G/VG2 (C57A G+5957VG/2)	1	057000272	251
C57A R	1	057000401	
5700A R/VI2 (C57A R+5957VI/2)	1	057000471	229
5700A R/VG2 (C57A R+5957VG/2)	1	057000472	251

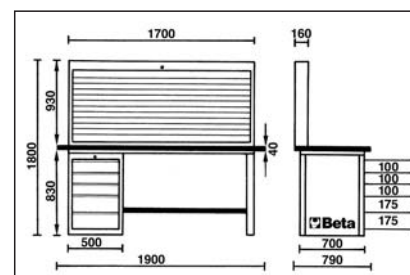

Beta



C57B - 5700B

banco da lavoro MasterCargo

• Modello con parete portautensili (C57P) e due cassettiere.

Cassettiera formata da cinque cassetti da 600x370 mm di cui 3 altezza 100 mm e 2 altezza 175 mm montati su guide telescopiche con scorrimento su cuscinetti per sopportare pesi rilevanti. Serratura centralizzata.

Parete portautensili anche appendibile mediante asole.

Tapparella in alluminio, manovrabile verticalmente, con serratura.

Tre pannelli forati amovibili per il sostegno degli utensili.

Piano di lavoro in legno multistrato, rivestito in laminato plastico con tre fori per la collocazione di una morsa 1599 M125/M150/M165, da ordinare separatamente.



C57B O



C57B G



5700B O



C57B R

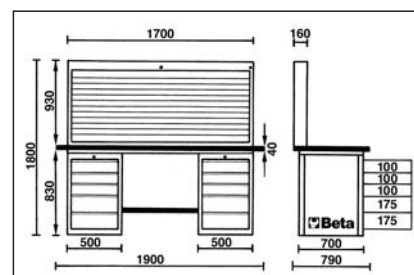

C57B O	1	057000002	
5700B O/VI2 (C57B O+5957VI/2)	1	057000073	229
5700B O/VG2 (C57B O+5957VG/2)	1	057000074	251
C57B G	1	057000202	
5700B G/VI2 (C57B G+5957VI/2)	1	057000273	229
5700B G/VG2 (C57B G+5957VG/2)	1	057000274	251
C57B R	1	057000402	
5700B R/VI2 (C57B R+5957VI/2)	1	057000473	229
5700B R/VG2 (C57B R+5957VG/2)	1	057000474	251

C57C

banco da lavoro MasterCargo

• Modello con due cassettiere.

Cassettiera formata da cinque cassetti da 600x370 mm di cui 3 altezza 100 mm e 2 altezza 175 mm montati su guide telescopiche con scorrimento su cuscinetti per sopportare pesi rilevanti. Serratura centralizzata.

Piano di lavoro in legno multistrato, rivestito in laminato plastico con tre fori per la collocazione di una morsa 1599 M125/M150/M165, da ordinare separatamente.



C57C O



C57C G



C57C R

C57C O	1	057000003
C57C G	1	057000203
C57C R	1	057000403

C57P - 5700P

parete portautensili MasterCargo

Parete portautensili anche appendibile mediante asole.

Tapparella in alluminio, manovrabile verticalmente, con serratura.

Tre pannelli forati amovibili per il sostegno degli utensili.



C57P O

1700 mm

930 mm

C57P O		1	057000020	
5700P O/U2	(C57P O+5957U/2)	1	057000079	234
C57P G		1	057000220	
5700P G/U2	(C57P G+5957U/2)	1	057000279	234
C57P R		1	057000420	
5700P R/U2	(C57P R+5957U/2)	1	057000479	234



C57P G



C57P R



5700P O/U

5700LAMP

lampada per banco MasterCargo

- Robusta struttura in lamiera composta da quattro elementi; completa di viti per l'assemblaggio.
- Portalampana con tubo fluorescente da 36W.
- Alimentazione 230V.
- Fornito senza cavo.



5700LAMP

1 057000005

5700LAMP + 5700A O

C58A - 5800A

banco da lavoro con parete Basic

Cassettiera composta da sei cassetti da 460x290 mm di cui 4 altezza 80 mm e 2 altezza 160 mm montati su guide telescopiche con serratura centralizzata frontale.

Pannello frontale forato per il sostegno degli utensili.
Possibilità di posizionamento anche a parete per mezzo di asole situate posteriormente.

Piano di lavoro in legno multistrato, rivestito in laminato plastico, con due fori per il fissaggio di una morsa 1599 M100 da ordinare separatamente.



C58A

5800A/U

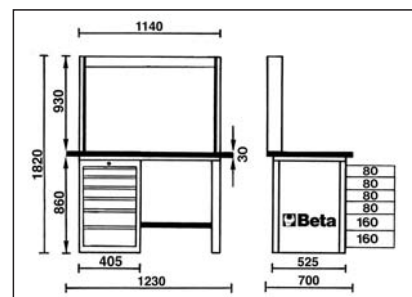

C58A		1	058000001	
5800A/U2	(C58A+5958U/2)	1	058000081	234

C58B - 5800B

banco da lavoro con parete BasicPlus

Cassettiera composta da sei cassetti da 460x290 mm di cui 4 altezza 80 mm e 2 altezza 160 mm montati su guide telescopiche con serratura centralizzata frontale.

La versione BasicPlus si differenzia per la chiusura a tapparella in alluminio con due pannelli forati amovibili per il sostegno degli utensili.
Struttura realizzata in lamiera di acciaio.

Piano di lavoro in legno multistrato, rivestito in laminato plastico, con due fori per il fissaggio di una morsa 1599 M100 da ordinare separatamente.



C58B

5800B/U

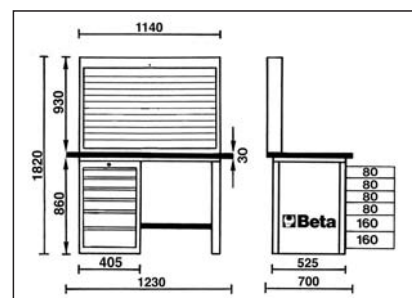

C58B		1	058000002	
5800B/U2	(C58B+5958U/2)	1	058000082	234

C58C

banco da lavoro

- Abbinabile alle pareti C58P/A e C58P/B.

Cassettiera composta da sei cassetti da 460x290 mm di cui 4 altezza 80 mm e 2 altezza 160 mm montati su guide telescopiche con serratura centralizzata frontale.

Piano di lavoro in legno multistrato, rivestito in laminato plastico, con due fori per il fissaggio di una morsa 1599 M100 da ordinare separatamente.



C58C

1 058000003

C58P/A - 5800UP/A

parete portautensili Basic

- Soluzione aperta.



C58P/A

1140 mm

930 mm



5800UP/A

C58P/A

1 058000020

5800P/AU2 (C58P/A+5958U/2)

1 058000086 234

C58P/B - 5800UP/B

parete portautensili BasicPlus

- Soluzione con chiusura a tapparella in alluminio verniciato e serratura di chiusura.
- Due pannelli forati amovibili per il sostegno degli utensili.



C58P/B

1140 mm

930 mm



5800UP/B

C58P/B

1 058000021

5800P/BU2 (C58P/B+5958U/2)

1 058000087 234

C56M

banco da lavoro

- Piano di lavoro in metallo rivestito per metà da lastra in alluminio antiscivolo e per metà da tappeto in gomma asportabile.
- Sottopiano in massello di legno.
- Capacità di carico statico: kg.800.
- Abbinabile alla parete C57P non fissabile al piano di lavoro.
- Tre cassetti dotati di serratura.
- Predisposizione per il fissaggio al pavimento.



C56M O



C56M G



C56M R

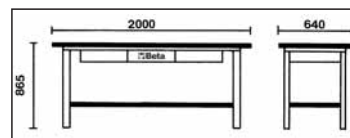

C56M O	1	056000050
C56M G	1	056000053
C56M R	1	056000054

C58M

banco da lavoro

- Piano di lavoro in metallo interamente rivestito da un tappetino in gomma antiscivolo asportabile.
- Sottopiano in massello di legno.
- Capacità di carico statico 2 ton.
- Abbinabile alla parete C58P non fissabile al piano di lavoro.
- 2 cassetti dotati di serratura.
- Predisposizione per il fissaggio al pavimento.
- Possibilità di applicazione opzionale del piano di lavoro in alluminio C58M/PA.

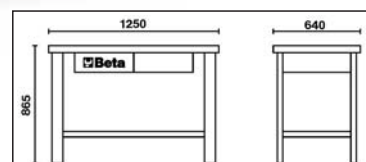

C58M	1	058000300
------	---	-----------

C58M/PA

piano in alluminio godronato per banco da lavoro C58M



C58M/PA	1	058000350
---------	---	-----------

 **Beta**

2252

seggolino con rotelle

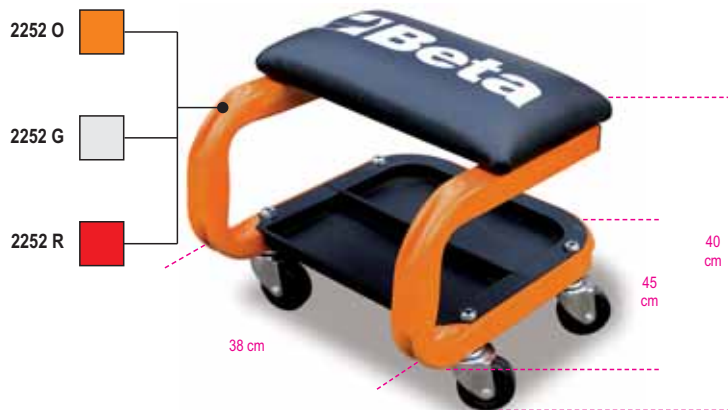

2252 O	1	022520001
2252 G	1	022520002
2252 R	1	022520003

2252KR4

ruote di ricambio seggiolino



2252KR4	1	022520900
---------	---	-----------

3000M/LT

lettino sottomacchina

- Rivestimento in PVC con imbottitura in gomma piuma per un elevato comfort.

**REGOLAZIONE DEL CUSCINO
TRAMITE PISTONE
A MOLLA PROGRESSIVA**



3000M/LT	1	030000220
----------	---	-----------

3000M/RLS

ruota di ricambio lettino sottomacchina



3000M/RLS	1	030000206
-----------	---	-----------

3010/T...



coppia cavalletti



	C max kg	H min mm	H max mm	H1 mm	L mm	L1 mm		
3010/T2	2000	280	425	245	185	165	1	030100002
3010/T3	3000	285	430	250	180	195	1	030100003
3010/T6	6000	400	580	340	245	280	1	030100006
3010/T10	10000	471	735	420	330	290	1	030100010

3011/T



sollevatori idraulici a bottiglia

	C max kg	H min mm	H max mm	L mm		
3011/T3,5	3500	170	366	86	1	030110035
3011/T5	5000	203	467	118	1	030110050
3011/T10	10000	220	484	114	1	030110100
3011/T15	15000	230	497	113	1	030110150



3012



staffa sostegno motore

	C max kg		
3012	500	1	030120010



3014

cavalletto sostegno motore

	C max kg		
3014	750	1	030140010



3020AL/1

sollevatore idraulico in alluminio

	C max kg	H min mm	H max mm	L mm	L1 mm	L2 mm		
3020AL/1	1500	82	445	667	294	170	1	030200001



Assortimenti di utensili per contenitori







ATTENZIONE!

Numerosi assortimenti, illustrati nelle prossime pagine, presentano variazioni:







- inserimento di nuovi utensili
- razionalizzazione degli utensili proposti.

Suggeriamo quindi di esaminare accuratamente la composizione di tali assortimenti e consultare le caratteristiche dell'articolo di riferimento.







Per manutenzioni industriali

Beta N.	N. pezzi				Beta N.	N. pezzi			
5902VI/1	103	1	059020021	221	5909VI/1	171	1	059090042	226
5904VI/3	98	1	059040041	222	5910VI/1	300	1	059100032	227
5904VI/4	149	1	059040042	223	5953VI/2	137	1	059530050	228
5908VI/2	237	1	059080041	224	5954VI/2	115	1	059540050	228
5908VI/3	195	1	059080063	225	5957VI/2	166	1	059570140	229





Per interventi universali

Beta N.	N. pezzi				Beta N.	N. pezzi			
5915U2	45	1	059150064	230	5915U/FR	80	1	059150085	233
5915U3	75	1	059150066	231	5938U/1	160	1	059380040	233
5915U5	49	1	059150067	232	5957U/2	132	1	059570160	234
5915U/AS1	71	1	059150071	232	5958U/2	86	1	059580140	234



Per elettronica, elettrotecnica e idraulica

Beta N.	N. pezzi				Beta N.	N. pezzi			
5980E/1A	58	1	059800311	235	5980E/6	98	1	059800306	236
5980E/2A	69	1	059800312	235	5980E/7	57	1	059800307	237
5980MQ/1	44	1	059800313	236	5980I/1	35	1	059800221	237

Per autoriparazione e movimento terra

Beta N.	N. pezzi				Beta N.	N. pezzi			
5902MT/1	106	1	059020023	238	5905VCR/1	93	1	059050047	245
5902MT1/AS	99	1	059020024	239	5908VG/4	171	1	059080042	245
5904VG/4	99	1	059040051	240	5908VG/5	208	1	059080053	246
5904VG/5	132	1	059040052	241	5909VG/2	160	1	059090061	247
5904VG/6	135	1	059040053	242	5910VG/1	316	1	059100036	248
5904VG/7	82	1	059040054	243	5953VG/2	147	1	059530060	249
5905VG/0	90	1	059050061	244	5954VG/2	138	1	059540060	250
5905VG/4	117	1	059050033	244	5957VG/2	185	1	059570150	251

Per motoriparazione

Beta N.	N. pezzi			
5940/M1	138	1	059400041	249

5902VI/1

Assortimento di 103 utensili

Manutenzioni industriali



19,5 kg

5902VI/1	059020021
 2200 O/VI1 (C22 O+5902VI/1)	022000341
 2200 G/VI1 (C22 G+5902VI/1)	022000346
 2200 R/VI1 (C22 R+5902VI/1)	022000349
 2300 O/VI1 (C23 O+5902VI/1)	023000341
 2300 G/VI1 (C23 G+5902VI/1)	023000346
 2300 R/VI1 (C23 R+5902VI/1)	023000349
 2300C O/VI1 (C23C O+5902VI/1)	023000381
 2300C G/VI1 (C23C G+5902VI/1)	023000386
 2300C R/VI1 (C23C R+5902VI/1)	023000388
 2500/VI1 (C25+5902VI/1)	025000341

N. pezzi/Descrizione

N. pezzi/Descrizione	Beta N.
4 cacciapina Ø 3 - 4 - 5 - 8 mm	31
1 bulino Ø 3 mm	32
1 scalpello piatto nervato 200 mm	35
26 chiavi combinate 6+32 mm	42/S26
12 chiavi a forchetta 6x7 - 8x9 - 10x11 - 12x13 - 14x15 - 16x17 - 18x19 - 20x22 - 21x23 - 24x26 - 25x28 - 30x32 mm	55/S12
9 chiavi maschio esagonale piegate 1,5 - 2 - 2,5 - 3 - 4 - 5 - 6 - 8 - 10 mm	96N/SP9
1 chiave regolabile a rullino 300 mm	110
13 chiavi a bussola poligonali 1/2" con guida 10+22 mm	920B/SB13
1 prolunga 125 mm - 1/2"	920/21
1 prolunga 255 mm - 1/2"	920/22
1 snodo 1/2"	920/25
1 quadro maschio 1/2" con spina scorrevole	920/42
1 cricchetto reversibile 1/2"	920/55
1 pinza regolabile cerniera chiusa 240 mm	1048
1 pinza regolabile autobloccante 240 mm	1052
1 tronchese a grande effetto taglienti diagonali 160 mm	1084BM
1 cesoia a lame larghe diritte 250 mm	1112
1 forbici per elettricisti, lame diritte	1128BMX
1 pinza universale 180 mm	1150BM
1 pinza a becchi mezzolondi diritti 160 mm	1166BM
7 giravite lama piatta 2,5x50 - 3x75 - 3,5x100 - 4x125 - 5,5x150 - 6,5x150 - 10x200 mm	1270
4 giravite Phillips® PH0x60 - PH1x80 - PH2x100 - PH3x150 mm	1272
1 martello tipo tedesco 500 g	1370
1 mazzuola antirimbalo Ø 40 mm	1392
1 punta per tracciare	1688A
1 flessometro 5 m	1691A/5
1 spessimetro a 20 lame	1708/20
5 lime taglio mezzodolce 200 mm	1719BMA/S5
1 seghetto	1726BM
1 oliatore in metallo a pressione 300 cc	1751
1 cutter	1771BM

5904VI/3

Assortimento di 98 utensili

Manutenzioni industriali



14,5 kg



Modello	Descrizione	Numero
5904VI/3		059040041
2400 O/VI3 (C24 O+5904VI/3)		024000277
2400 G/VI3 (C24 G+5904VI/3)		024000278
2400 R/VI3 (C24 R+5904VI/3)		024000279
2400CX O/VI3 (CX24 O+5904VI/3)		024000423
2400CX G/VI3 (CX24 G+5904VI/3)		024000424
2400CX R/VI3 (CX24 R+5904VI/3)		024000425
2400H6 O/VI3 (C24H6 O+5904VI/3)		024000642
2400H6 G/VI3 (C24H6 G+5904VI/3)		024000643
2400H6 R/VI3 (C24H6 R+5904VI/3)		024000644
3600 O-5/VI3 (C36 O/5+5904VI/3)		036000111
3600 G-5/VI3 (C36 G/5+5904VI/3)		036000112
3600 R-5/VI3 (C36 R/5+5904VI/3)		036000113
3600 O-7/VI3 (C36 O/7+5904VI/3)		036000114
3600 G-7/VI3 (C36 G/7+5904VI/3)		036000115
3600 R-7/VI3 (C36 R/7+5904VI/3)		036000116

N. pezzi/Descrizione

N. pezzi	Descrizione	Beta N.
2	scalpelli piatti nervati 100 - 200 mm	35
21	chiavi combinate 6+22 - 24 - 27 - 30 - 32 mm	42
8	chiavi a forchetta 6x7 - 8x9 - 10x11 - 12x13 - 14x15 - 16x17 - 18x19 - 20x22 mm	55
9	chiavi maschio esagonale piegate 1,5 - 2 - 2,5 - 3 - 4 - 5 - 6 - 8 - 10 mm	96/SP9
19	chiavi a bussola esagonali 1/2" 10+24 - 26 - 27 - 30 - 32 mm	920A
5	chiavi a bussola maschio esagonale 1/2" 5 - 6 - 8 - 10 - 12 mm	920ME
1	prolunga 125 mm - 1/2"	920/21
1	prolunga 255 mm - 1/2"	920/22
1	snodo 1/2"	920/25
1	quadro maschio 1/2" con spina scorrevole	920/42
1	criccheto reversibile 1/2"	920/55
6	chiavi a T maschio esagonale 2,5 - 3 - 4 - 5 - 6 - 8 mm	951
1	pinza becchi dritti per anelli elastici, per fori 180 mm	1032
1	pinza becchi piegati per anelli elastici, per fori 170 mm	1034
1	pinza becchi dritti per anelli elastici, per alberi 175 mm	1036
1	pinza becchi piegati per anelli elastici, per alberi 175 mm	1038
1	pinza regolabile cerniera chiusa 240 mm	1048
1	pinza regolabile autobloccante 240 mm	1052
1	tronchese a grande effetto taglienti diagonali 160 mm	1084BM
1	pinza universale 180 mm	1150BM
1	pinza a becchi mezzotondi dritti 160 mm	1166BM
4	giravite lama piatta 3x75 - 4x100 - 5,5x150 - 6,5x150 mm	1270
3	giravite Phillips® PH0x60 - PH1x80 - PH2x100 mm	1272
1	martello tipo tedesco 300 g	1370
1	mazzuola con battente in materiale plastico Ø 35 mm	1390
5	lime a taglio mezzodolce 200 mm	1719BMA/SS

5904VI/4

Assortimento di 149 utensili

Manutenzioni industriali



22 kg

Modello	Numero
5904VI/4	059040042
2400 O/VI4 (C24 O+5904VI/4)	024000267
2400 G/VI4 (C24 G+5904VI/4)	024000268
2400 R/VI4 (C24 R+5904VI/4)	024000269
2400H O/VI4 (C24H O+5904VI/4)	024000566
2400H G/VI4 (C24H G+5904VI/4)	024000568
2400H R/VI4 (C24H R+5904VI/4)	024000569
2400XL/VI4 (C24XL+5904VI/4)	024000145
3600 O-7/VI4 (C36 O/7+5904VI/4)	036000164
3600 G-7/VI4 (C36 G/7+5904VI/4)	036000165
3600 R-7/VI4 (C36 R/7+5904VI/4)	036000166
3900 O/VI4 (C39 O+5904VI/4)	039000061
3900 G/VI4 (C39 G+5904VI/4)	039000062
3900 R/VI4 (C39 R+5904VI/4)	039000063

N. pezzi/Descrizione

N. pezzi/Descrizione	Beta N.
5 cacciapina Ø 2 - 3 - 4 - 5 - 6 mm	31
1 bulino Ø 4 mm	32
2 scalpelli piatti nervati 100 - 200 mm	35
21 chiavi combinate 6x22 - 24 - 27 - 30 - 32 mm	42
12 chiavi a forchetta 6x7 - 8x9 - 10x11 - 12x13 - 14x15 - 16x17 - 18x19 - 20x22 - 21x23 - 24x26 - 27x29 - 30x32 mm	55
9 chiavi a bussola esagonale piegate 1,5 - 2 - 2,5 - 3 - 4 - 5 - 6 - 8 - 10 mm	96N/SP9
13 chiavi a bussola esagonali 1/4" 4+14 mm	900
6 chiavi a bussola maschio esagonale 1/4" 2,5+8 mm	900ME
1 prolunga 50 mm - 1/4"	900/20
1 prolunga 150 mm - 1/4"	900/21
1 snodo 1/4"	900/25
1 quadro con impugnatura 1/4"	900/30
1 quadro scorrevole 1/4"	900/42
1 cricchetto reversibile 1/4"	900/55
19 chiavi a bussola esagonali 1/2" 10+24 - 26 - 27 - 30 - 32 mm	920A
5 chiavi a bussola maschio esagonale 1/2" 5 - 6 - 8 - 10 - 12 mm	920ME
1 prolunga 125 mm - 1/2"	920/21
1 prolunga 255 mm - 1/2"	920/22
1 snodo 1/2"	920/25
1 quadro maschio 1/2" con spina scorrevole	920/42
1 cricchetto reversibile 1/2"	920/55
6 chiavi a T maschio esagonale 2,5 - 3 - 4 - 5 - 6 - 8 mm	951
1 pinza becchi dritti per anelli elastici, per fori 180 mm	1032
1 pinza becchi piegati per anelli elastici, per fori 170 mm	1034
1 pinza becchi dritti per anelli elastici, per alberi 175 mm	1036
1 pinza becchi piegati per anelli elastici, per alberi 175 mm	1038
1 pinza regolabile cerniera chiusa 240 mm	1048
1 pinza regolabile autobloccante 240 mm	1052
1 tronchese a grande effetto taglienti diagonali 160 mm	1084BM
1 cesoia a lame larghe diritte 240 mm	1112
1 forbici per elettricisti, lame diritte	1128BM
1 pinza universale 180 mm	1150BM
1 pinza a becchi mezzotondi dritti 160 mm	1166BM
7 giravite lama piatta 2,5x50 - 3x75 - 3,5x100 - 4x125 - 5,5x100 - 5,5x150 - 6,5x150 mm	1270
6 giravite Phillips® PH0x60 - PH0x100 - PH1x80 - PH1x120 - PH2x100 - PH2x150 mm	1272
1 martello tipo tedesco 300 g	1370
1 mazzuola con battente in materiale plastico Ø 35 mm	1390
5 lime a taglio mezzodolce 200 mm	1719BMA/S5
1 seghetto	1726
5 lame per seghetti	1728BM
1 rivettatrice	1741
100 rivetti 2,9x6 mm	1741RV
100 rivetti 3,2x8 mm	1741RV
100 rivetti 3,8x10 mm	1741RV
100 rivetti 4x12 mm	1741RV
100 rivetti 4,8x12 mm	1741RV
1 oliatore in plastica a pressione 200 cc	1753
1 termoformato vuoto	VP5

Manutenzioni industriali

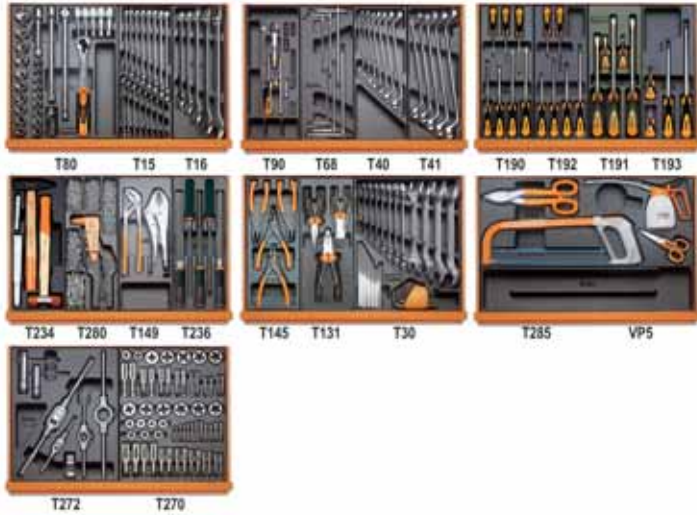

5908VI/2	059080051
2800N O/VI2 (C28N+5908/VI2)	028000252
2800N G/VI2 (C28N+5908/VI2)	028000262
2800N R/VI2 (C28N+5908/VI2)	028000263
2800T O/VI2 (C28T+5908/VI2)	028000272
2800T G/VI2 (C28T+5908/VI2)	028000282
2800T R/VI2 (C28T+5908/VI2)	028000292

N. pezzi/Descrizione

Beta N.

5	cacciaspina Ø 2 - 3 - 4 - 5 - 6 mm	31
1	bulino Ø 4 mm	32
21	scalpelli piatti nervati 100 - 200 mm	35
2	chiavi combinate 6-22 - 24 - 27 - 30 - 32 mm	42
12	chiavi a forchetta 6x7 - 8x9 - 10x11 - 12x13 - 14x15 - 16x17 - 18x19 - 20x22 - 21x23 - 24x26 - 27x29 - 30x32 mm	55
12	chiavi poligonali curve 6x7 - 8x9 - 10x11 - 12x13 - 14x15 - 16x17 - 18x19 - 20x22 - 21x23 - 24x26 - 25x28 - 27x29 mm	90
9	chiavi maschio esagonali piegate 1,5 - 2 - 2,5 - 3 - 4 - 5 - 6 - 8 - 10 mm	96N/SP9
26	maschi a mano passo grosso M3 - 4 - 5 - 6 - 7 - 8 - 9 - 10 - 12 - 14 - 16 - 18 - 20	430
14	maschi a mano passo fine M6x0,75 - M8x1 - M10x1,25 - M12x1,5 - M14x1,5 - M16x1,5 - M18x1,5	433
1	giramaschi regolabile M3+M12	435/1,5
1	giramaschi regolabile M5+M21	435/3
1	giramaschi a cricchetto reversibile 2,0+5,0 mm (M3+M8)	436/1
1	giramaschi a cricchetto reversibile 4,6+8,0 mm (M5+M12)	436/2
7	filiere tonde passo grosso M3 - 4 - 5 - 6 - 7 - 8 - 9	440
6	filiere tonde passo grosso M10 - 12 - 14 - 16 - 18 - 20	440A
2	filiere tonde passo fine M6x0,75 - M8x0,75	441
5	filiere tonde passo fine M10x1,25 - M12x1,5 - M14x1,5 - M16x1,5 - M18x1,5	441A
1	girafiliera 25,4 mm	444/1
1	girafiliera 38,1 mm	444/2
13	chiavi a bussola esagonali 1/4" 4+14 mm	900
6	chiavi a bussola maschio esagonale 1/4" 2,5 - 3 - 4 - 5 - 6 - 8 mm	900ME
1	prolunga 50 mm - 1/4"	900/20
1	prolunga 150 mm - 1/4"	900/21
1	snodo 1/4"	900/25
1	quadro con impugnatura 1/4"	900/30
1	quadro scorrevole 1/4"	900/42
1	cricchetto reversibile 1/4"	900/55
19	chiavi a bussola esagonali 1/2" 10+24 - 26 - 27 - 30 - 32 mm	920A
5	chiavi a bussola maschio esagonale 1/2" 5 - 6 - 8 - 10 - 12 mm	920ME
1	prolunga 125 mm - 1/2"	920/21
1	prolunga 255 mm - 1/2"	920/22
1	snodo 1/2"	920/25
1	quadro maschio 1/2" con spina scorrevole	920/42
1	cricchetto reversibile 1/2"	920/55
6	chiavi a T maschio esagonale 2,5 - 3 - 4 - 5 - 6 - 8 mm	951
1	pinza becchi dritti per anelli elastici, per fori 180 mm	1032
1	pinza becchi piegati per anelli elastici, per fori 170 mm	1034
1	pinza becchi dritti per anelli elastici, per alberi 175 mm	1036
1	pinza becchi piegati per anelli elastici, per alberi 175 mm	1038
1	pinza regolabile cerniera chiusa 240 mm	1048
1	pinza regolabile autobloccante 240 mm	1052
1	tronchese a grande effetto taglienti diagonali 160 mm	1084BM
1	cesoia a lame larghe diritte 250 mm	1112
1	forbici per elettricisti lame dritte	1128BM
1	pinza universale 180 mm	1150BM
1	pinza a becchi mezzotondi dritti 160 mm	1166BM
10	giravite lama piatta 2,5x50 - 3x75 - 3,5x100 - 4x125 - 5,5x100 - 5,5x150 - 6,5x150 - 8x200 - 10x150 - 10x200 mm	1270
8	giravite Phillips® PH0x60 - PH0x100 - PH1x80 - PH1x120 - PH2x100 - PH2x150 - PH3x150 - PH4x200 mm	1272
2	giravite nani lama piatta 4x30 - 6,5x30 mm	1270N
2	giravite nani Phillips® PH1x30 - PH2x30 mm	1272N
1	martello tipo tedesco 300 g	1370
1	mazzuola con battente in materiale plastico Ø 35 mm	1390
1	contafiletti ISO 0,25+6 W 62+4x1"	1707
5	lime taglio mezzodolce 200 mm	1719BMA/S5
1	seghetto	1726
5	lame per seghetti	1728BM
1	rivettatrice 250 mm	1741
100	rivetti 2,9x6 mm	1741RV
100	rivetti 3,2x8 mm	1741RV
100	rivetti 3,8x10 mm	1741RV
100	rivetti 4x12 mm	1741RV
100	rivetti 4,8x12 mm	1741RV
1	oliatore in plastica a pressione 200 cc	1753
1	termoformato vuoto	VP5

5908VI/3

Assortimento di 195 utensili

Manutenzioni industriali



56 kg

5908VI/3 059080063



2800N O/VI3 028000255
(C28N O+5908VI/3)



2800N G/VI3 028000265
(C28N G+5908VI/3)



2800N R/VI3 028000269
(C28N R+5908VI/3)



2800T O/VI3 028000275
(C28T O+5908VI/3)



2800T G/VI3 028000285
(C28T G+5908VI/3)



2800T R/VI3 028000289
(C28T R+5908VI/3)



3000VI3 030000051
(C30+5908VI/3)

N. pezzi/Descrizione

N. pezzi/Descrizione	Beta N.
6 cacciapina Ø 2 - 3 - 4 - 5 - 6 - 8 mm	31/B6
1 bulino Ø 4 mm	32
2 scalpelli piatti nervati 125 - 250 mm	35
1 ugnetto nervato 200 mm	37
30 chiavi combinate 6+32 - 35 - 36 - 38 - 41 mm	42
14 chiavi a forchetta 6x7 - 8x9 - 10x11 - 12x13 - 14x15 - 16x17 18x19 - 20x22 - 21x23 - 24x26 - 25x28 - 27x29 - 30x32 - 36x41 mm	55
13 chiavi poligonali curve 6x7 - 8x9 - 10x11 - 12x13 - 14x15 - 16x17 18x19 - 20x22 - 21x23 - 24x26 - 25x28 - 27x29 - 30x32 mm	90
10 chiavi maschio esagonale piegate 1,5+12 mm	96N/B10
4 chiavi maschio esagonale piegate 13 - 14 - 17 - 19 mm	96N
1 chiave regolabile a rullino 250 mm	110
13 chiavi a bussola poligonali 1/2" con guida 10+22 mm	920B/SB13
8 chiavi a bussola poligonali 1/2" con guida 23+32 mm	920B/SB8
7 chiavi a bussola maschio esagonale con guida 1/2" 5 - 6 - 8 - 10 - 12 - 14 - 17 mm	920ME/SB7
1 prolunga 125 mm - 1/2"	920/21
1 prolunga 255 mm - 1/2"	920/22
1 snodo 1/2"	920/25
1 quadro maschio a T snodato 1/2"	920/40
1 quadro maschio 1/2" con spina scorrevole	920/42
1 cricchetto con quadro scorrevole 1/2"	920/50
12 chiavi a pipa doppie esagonali-poligonali 8 - 10 - 11 - 13 - 14 - 17 - 19 - 22 - 24 - 27 - 30 - 32 mm	932
5 chiavi a T con maschio esagonale snodato 3 - 4 - 5 - 6 - 8 mm	953
1 pinza a becchi piatti dritti 160 mm	1008BM
3 pinze becchi dritti per anelli elastici, per fori 180 - 225 - 300 mm	1032
3 pinze becchi piegati per anelli elastici, per fori 170 - 210 - 290 mm	1034
3 pinze becchi dritti per anelli elastici, per alberi 140x1,3 - 175 - 225 mm	1036
3 pinze becchi piegati per anelli elastici, per alberi 135x1,3 - 175 - 220 mm	1038
2 pinze regolabile cerniera chiusa 240 - 300 mm	1048
1 pinza autobloccante a doppia regolazione	1051
1 tronchese a grande effetto taglienti diagonali 160 mm	1084BM
1 tronchese doppia leva taglio frontale 180 mm	1092V
1 cesoia a lame larghe diritte 300 mm	1112
1 cesoia a lame strette diritte 200 mm	1114
1 forbici per elettricisti lame diritte	1128BMX
1 pinza universale 180 mm	1150BM
1 pinza a becchi mezzotondi piegati 160 mm	1168BM
11 giravite lama piatta 2,5x50 - 3x75 - 3,5x100 - 4x125 5,5x150 - 5,5x200 - 6,5x150 - 6,5x200 - 8x150 - 10x200 - 12x250 mm	1270
5 giravite Phillips® PH0x60 - PH1x80 - PH2x100 - PH3x150 - PH4x200 mm	1272
2 giravite nani lama piatta 4x30 - 6,5x30 mm	1270N
2 giravite nani Phillips® PH1x30 - PH2x30 mm	1272N
2 martelli tipo tedesco 300 - 600 g	1370
2 mazzuole con battente in materiale plastico Ø 35 - 60 mm	1390
1 estrattore universale a due griffe 25+130 mm	1500N/2
1 estrattore universale a due griffe 80+250 mm	1500N/5
1 calibro a corsoio	1650
1 riga semiringida 300 mm	1683
1 punta per tracciare	1688A
1 flessometro 5 m	1691A/5
1 spessimetro a 13 lame	1708/13
1 flessibile magnetico 1,8 kg	1712E/2
5 lime taglio mezzodolce 200 mm	1719BMA/S5
1 seghetto	1726BM
1 oliatore in metallo a pressione 200 cc	1751

5909VI/1

Assortimento di 171 utensili

Manutenzioni industriali



26 kg

5909VI/1

059090042



3900 O/VI1
(C39 O+5909VI/1)

039000051



3900 G/VI1
(C39 G+5909VI/1)

039000052



3900 R/VI1
(C39 R+5909VI/1)

039000053

N. pezzi/Descrizione

Beta N.

6	cacciaspina Ø 2 - 3 - 4 - 5 - 6 - 8 mm	31/B6
1	bulino Ø 4 mm	32
2	scalpelli piatti nervati 125 - 250 mm	35
1	ugnetto nervato 150 mm	37
26	chiavi combinate 6+32 mm	42/S26
13	chiavi a forchetta 6x7 - 8x9 - 10x11 - 12x13 - 14x15 - 16x17 18x19 - 20x22 - 21x23 - 24x26 - 25x28 - 27x29 - 30x32 mm	55/S13
10	chiavi maschio esagonale piegate 1,5 - 2 - 2,5 - 3 - 4 - 5 - 6 - 8 - 10 - 12 mm	96N/B10
1	chiave regolabile a rullino 250 mm	110
13	chiavi a bussola poligonali 1/2" con guida 10+22 mm	920B/SB13
8	chiavi a bussola poligonali 1/2" con guida 23+32 mm	920B/SB8
7	chiavi a bussola maschio esagonale 5+17 mm	920ME/SB7
1	prolunga 125 mm - 1/2"	920/21
1	prolunga 255 mm - 1/2"	920/22
1	snodo 1/2"	920/25
1	quadro maschio a T snodato 1/2"	920/40
1	quadro maschio 1/2" con spina scorrevole	920/42
1	cricchetto con quadro scorrevole 1/2"	920/50
8	chiavi a tubo doppie serie pesante 6x7+20x22 mm	930/S8
14	chiavi a T maschio esagonale 2+14 mm	951/S14
1	pinza a becchi piatti dritti 160 mm	1008BM
2	pinze becchi dritti per anelli elastici, per fori 180 - 225 mm	1032
1	pinza becchi piegati per anelli elastici, per fori 170 mm	1034
2	pinze becchi dritti per anelli elastici, per alberi 175 - 225 mm	1036
1	pinza becchi piegati per anelli elastici, per alberi 175 mm	1038
1	pinza regolabile cerniera chiusa 240 mm	1048
1	pinza autobloccante a doppia regolazione	1051
1	tronchese a grande effetto taglienti diagonali 160 mm	1084BM
1	tronchese doppia leva taglio frontale 180 mm	1092V
1	cesoia a lame larghe diritte 250 mm	1112
1	forbici per elettricisti lame dritte	1128BMX
1	pinza universale 180 mm	1150BM
1	pinza a becchi mezzotondi piegati 160 mm	1168BM
4	giravite lama piatta 5,5x100 - 6,5x150 - 8x200 - 10x200 mm	1270
4	giravite Phillips® PH0x60 - PH1x80 - PH2x100 - PH3x150 mm	1272/S4
4	giravite lama parallela 2,5x60 - 3x100 - 4x100 - 5x125 mm	1274
12	chiavi maschio con impugnatura per viti con impronta Torx® T6+T45	1277TX/S12
2	martelli tipo tedesco 300 - 600 g	1370
1	mazzuola con battente in materiale plastico Ø 45 mm	1390
1	calibro a corsoio	1650
1	riga semirigida 300 mm	1683
1	punta per tracciare	1688A
1	flessometro 5 m	1691A/5
1	spessimetro a 20 lame	1708/20
1	flessibile magnetico 1,8 kg	1712E/2
5	lime taglio mezzodolce 200 mm	1719BMA/S5
1	seghetto	1726BM
1	oliatore in metallo a pressione 300 cc	1751

Manutenzioni industriali



5910VI/1

059100032



3000VI1

(C30+5910VI/1)

030000063

N. pezzi/Descrizione

Beta N.

6	cacciapina Ø 2 - 3 - 4 - 5 - 6 - 8 mm	31/B6
1	bulino Ø 4 mm	32
2	scalpelli piatti nervati 125 - 250 mm	35
1	ugnetto nervato 200 mm	37
4	chiavi combinate 35 - 36 - 38 - 41 mm	42
26	chiavi combinate 6+32 mm	42/S26
1	chiave a forchetta 36x41 mm	55
13	chiavi a forchetta 6x7 - 8x9 - 10x11 - 12x13 - 14x15 - 16x17 - 18x19 - 20x22 - 21x23 - 24x26 - 25x28 - 27x29 - 30x32 mm	55/S13
13	chiavi poligonali curve 6x7+30x32 mm	90/S13
4	chiavi maschio esagonale piegate 13 - 14 - 17 - 19 mm	96N
10	chiavi maschio esagonale piegate 1,5 - 2 - 2,5 - 3 - 4 - 5 - 6 - 8 - 10 - 12 mm	96N/B10
1	chiave regolabile a rullino 250 mm	110
1	giratubi modello americano 300 mm	362
25	punte elicoidali cilindriche, serie corta 1+13x0,5 mm	412/SP25
37	assortimento di maschi e filiere in acciaio HSS	447/C37
1	chiave dinamometrica a scatto 1/2" 40+200 Nm	606/20
13	chiavi a bussola poligonali 1/2" con guida 10+22 mm	920B/SB13
8	chiavi a bussola poligonali 1/2" con guida 23+32 mm	920B/SB8
4	chiavi a bussola maschio esagonale 1/2" 10 - 12 - 14 - 17 mm	920ME
1	prolunga 125 mm - 1/2"	920/21
1	prolunga 255 mm - 1/2"	920/22
1	snodo 1/2"	920/25
1	quadro maschio a T snodato 1/2"	920/40
1	quadro maschio 1/2" con spina scorrevole	920/42
1	cricchetto con quadro scorrevole 1/2"	920/50
13	assortimento di 9 chiavi a bussola e 5 accessori 3/4"	928A/C9SN
12	chiavi a pipa doppie esagonali-poligonali 8 - 10 - 11 - 13 - 14 - 17 - 19 - 22 - 24 - 27 - 30 - 32 mm	932
14	chiavi a T maschio esagonale 2+14 mm	951/S14
5	chiavi a T con maschio esagonale snodato 3 - 4 - 5 - 6 - 8 mm	953
1	pinza a becchi piatti dritti 160 mm	1008BM
3	pinze becchi dritti per anelli elastici, per fori 180 - 225 - 300 mm	1032
3	pinze becchi piegati per anelli elastici, per fori 170 - 210 - 290 mm	1034
3	pinze becchi dritti per anelli elastici, per alberi 140x1,3 - 175 - 225 mm	1036
3	pinze becchi piegati per anelli elastici, per alberi 135x1,3 - 175 - 220 mm	1038
2	pinze regolabili cerniera chiusa 240 - 300 mm	1048
1	pinza autobloccante a doppia regolazione	1051
1	tronchese a grande effetto taglianti diagonali 160 mm	1084BM
1	tronchese doppia leva taglio frontale 180 mm	1092V
1	cesoia a lame larghe diritte 300 mm	1112
1	cesoia a lame strette diritte 200 mm	1114
1	forbici per elettricisti, lame diritte	1128BMX
1	pinza universale 180 mm	1150BM
1	pinza a becchi mezzotondi piegati 160 mm	1168BM
12	giravite lama piatta 3x75 - 3x100 - 4x100 - 4x150 - 5,5x100 - 5,5x200 - 6,5x100 - 6,5x200 - 8x150 - 10x150 - 10x200 - 12x250 mm	1270
2	giravite nani lama piatta 4x30 - 6,5x30 mm	1270N
9	giravite Phillips® PH0x60 - PH0x100 - PH1x80 - PH1x120 - PH1x150 - PH2x100 - PH2x150 - PH3x150 - PH4x200 mm	1272
2	giravite nani Phillips® PH1x30 - PH2x30 mm	1272N
2	giravite Phillips® 1000V PH1x80 - PH2x100 mm	1272MQ
3	giravite a lama parallela 1000V 3x100 - 4x100 - 5,5x125 mm	1274MQ
2	martelli tipo tedesco 300 - 600 g	1370
2	mazzuole con battente in materiale plastico Ø 35 - 60 mm	1390
5	estrattori conici M3+M18	1430/S5
1	estrattore universale a due griffe 25+130 mm	1500/2
1	estrattore universale a due griffe 80+250 mm	1500/5
1	calibro a corsoio	1650
1	riga semirigida 300 mm	1683
1	punta per tracciare	1688A
1	flessometro 5 m	1691A/5
1	spessimetro a 13 lame	1708/13
1	flessibile magnetico 1,8 kg	1712E/2
5	lime taglio mezzodolce 200 mm	1719BMA/S5
1	seghetto	1726BM
1	rivettatrice	1741
1	oliatore in metallo a pressione 200 cc	1751

5953VI/2

Assortimento di 137 utensili

Manutenzioni industriali



22,5 kg

5953VI/2

059530050



5300VI/2

(C53VI+5953VI/2)

053000031

N. pezzi/Descrizione

N. pezzi/Descrizione	Beta N.
5 cacciaspina Ø 2 - 3 - 4 - 5 - 6 mm	31
1 bulino Ø 4 mm	32
2 scalpelli piatti nervati 200 - 250 mm	35
18 chiavi combinate 6+14 - 16 - 17 - 18 - 19 - 21 - 22 - 24 - 27 - 30 mm	42
12 chiavi a forchetta 6x7 - 8x9 - 10x11 - 12x13 - 14x15 - 16x17 - 18x19 - 20x22 - 21x23 - 24x26 - 27x29 - 30x32 mm	55
12 chiavi maschio esagonale piegate 2+10 mm	96/SP12
1 chiave regolabile a rullino 250 mm	110
1 giratubi svedese 320 mm	374
20 chiavi a bussola poligonali 1/2" 10+24 - 26 - 27 - 28 - 30 - 32 mm	920B
6 chiavi a bussola maschio esagonale 1/2" 5 - 6 - 8 - 10 - 12 - 14 mm	920ME
1 prolunga 125 mm - 1/2"	920/21
1 prolunga 255 mm - 1/2"	920/22
1 snodo 1/2"	920/25
1 quadro maschio a T snodato 1/2"	920/40
1 quadro maschio 1/2" con spina scorrevole	920/42
1 cricchetto reversibile 1/2"	920/55
6 chiavi a T maschio esagonale 2,5 - 3 - 4 - 5 - 6 - 8 mm	951
2 pinze becchi dritti per anelli elastici, per fori 140 - 180 mm	1032
1 pinza becchi piegati per anelli elastici, per fori 170 mm	1034
2 pinze becchi dritti per anelli elastici, per alberi 140x1,3 - 175 mm	1036
1 pinza becchi piegati per anelli elastici, per alberi 175 mm	1038
1 pinza regolabile cerniera chiusa 240 mm	1048
1 pinza regolabile autobloccante 240 mm	1052
1 tronchese a grande effetto taglienti diagonali 160 mm	1084BM
1 tronchese doppia leva taglio frontale 180 mm	1092V
1 cesoia a lame larghe diritte 250 mm	1112
1 forbici per elettricisti lame dritte	1128BMX
1 pinza universale 180 mm	1150BM
1 pinza a becchi mezzotondi dritti 160 mm	1166BM
1 giravite cercafase	1260
9 giravite lama piatta 3x75 - 4x100 - 4x150 - 5,5x100 - 5,5x150 - 6,5x150 - 8x150 - 10x200 - 12x250 mm	1270
2 giravite nani lama piatta 4x30 - 6,5x30 mm	1270N
8 giravite Phillips® PH0x60 - PH0x100 - PH1x80 - PH1x120 - PH2x100 - PH2x150 - PH3x150 - PH4x200 mm	1272
2 giravite nani Phillips® PH1x30 - PH2x30 mm	1272N
2 martelli tipo tedesco 300 - 500 g	1370
1 mazzuola con battente in materiale plastico Ø 45 mm	1390
1 flessibile magnetico 0,5 kg	1712E/1
5 lime taglio mezzodolce 200 mm	1719BMA/S5
1 seghetto	1726BM
1 oliatore in plastica a pressione 250 cc	1754

5954VI/2

Assortimento di 115 utensili

Manutenzioni industriali



17 kg

5954VI/2

059540050



5400 O/VI2

(C54VI O+5954VI/2)

054000070



5400 G/VI2

(C54VI G+5954VI/2)

054000072



5400 R/VI2

(C54VI R+5954VI/2)

054000074

N. pezzi/Descrizione

N. pezzi/Descrizione	Beta N.
2 punzoni Ø 2 - 3 mm	30
5 cacciaspina Ø 2 - 3 - 4 - 5 - 6 mm	31
1 bulino Ø 4 mm	32
1 scalpello piatto normale 150 mm	34
1 ugnetto normale 150 mm	36
18 chiavi combinate 6+22 - 24 mm	42
12 chiavi a forchetta 6x7 - 8x9 - 10x11 - 12x13 - 14x15 - 16x17 - 18x19 - 20x22 - 21x23 - 24x27 - 25x28 - 30x32 mm	55/S12X
12 chiavi maschio esagonale piegate 2+10 mm	96/SP12
1 chiave regolabile a rullino 250 mm	110
20 chiavi a bussola esagonali 1/2" 10+24 - 26 - 27 - 28 - 30 - 32 mm	920A
1 prolunga 125 mm - 1/2"	920/21
1 prolunga 255 mm - 1/2"	920/22
1 snodo 1/2"	920/25
1 quadro maschio 1/2" con spina scorrevole	920/42
1 cricchetto reversibile 1/2"	920/55
1 pinza becchi dritti per anelli elastici, per fori 180 mm	1032
1 pinza becchi piegati per anelli elastici, per fori 170 mm	1034
1 pinza becchi dritti per anelli elastici, per alberi 175 mm	1036
1 pinza becchi piegati per anelli elastici, per alberi 175 mm	1038
1 pinza regolabile cerniera chiusa 240 mm	1048
1 pinza regolabile autobloccante 240 mm	1052
1 tronchese a taglienti diagonali 160 mm	1082BM
1 cesoia a lame larghe diritte 250 mm	1112
1 forbici per elettricisti lame dritte	1128BMX
1 pinza universale 180 mm	1150BM
1 pinza a becchi mezzotondi dritti 160 mm	1166BM
1 pinza a becchi mezzotondi piegati 200 mm	1168BM
5 giravite lama piatta 3x75 - 4x125 - 5,5x150 - 6,5x200 - 10x200 mm	1270
1 giravite nano lama piatta 4x30 mm	1270N
3 giravite Phillips® PH0x60 - PH1x80 - PH2x100 mm	1272
1 giravite nano Phillips® PH1x30 mm	1272N
1 martello tipo tedesco 400 g	1370
1 mazzuola antirimbombo Ø 35 mm	1392
1 estrattore a due griffe oscillanti	1515/3
1 pinza per capicorda preisolati	1602
1 flessometro 5 m	1691A/5
1 spessimetro a 20 lame	1708/20
1 flessibile magnetico 1,8 kg	1712E/2
5 lime taglio mezzodolce 200 mm	1719BMA/S5
1 seghetto	1726BM
1 rivettatrice	1741
1 oliatore in plastica a pressione 250 cc	1754

5957VI/2

Assortimento di 166 utensili



Manutenzioni industriali







 32 kg



N. pezzi/Descrizione



N. pezzi/Descrizione	Beta N.
1 assortimento di 132 utensili	5957U
2 scalpelli piatti nervati 200 - 250 mm	35
1 ugnetto nervato 200 mm	37
7 chiavi maschio esagonale con impugnatura 2,5+6 mm	96T/S7
10 chiavi a pipa doppie esagonali - poligonali 8 - 10 - 11 - 13 - 14 - 17 - 19 - 22 - 24 - 27 mm	932
1 pinza becchi dritti per anelli elastici, per fori 140 mm	1032
1 pinza becchi piegati per anelli elastici, per fori 130 mm	1034
1 pinza becchi dritti per anelli elastici, per alberi 140x1,3 mm	1036
1 pinza becchi piegati per anelli elastici, per alberi 135x1,3 mm	1038
1 pinza regolabile autobloccante 280 mm	1060
1 pinza regolabile autobloccante 290 mm	1062
1 martello tipo tedesco 1000 g	1370
1 mazzuola antirimbazzo Ø 50 mm	1392
1 estrattore universale a due griffe 25+130 mm	1500N/2
1 calibro a corsoio	1650
1 riga semirigida 300 mm	1683
1 punta per tracciare	1688A
1 spessimetro a 13 lame	1708/13
1 coltello a serramanico	1777BM



 5957VI/2  059570140



 5700A O/VI2  057000071
(C57A O+5957VI/2)

 5700A G/VI2  057000271
(C57A G+5957VI/2)

 5700A R/VI2  057000471
(C57A R+5957VI/2)

 5700B O/VI2  057000073
(C57B O+5957VI/2)

 5700B G/VI2  057000273
(C57B G+5957VI/2)

 5700B R/VI2  057000473
(C57B R+5957VI/2)

5915U2

Assortimento di 45 utensili

Universali



 5 kg

N. pezzi/Descrizione

N. pezzi/Descrizione	Beta N.
2 punzoni Ø 2-3 mm	30
1 bulino Ø 4 mm	32
2 scalpelli piatti 125-150 mm	34
1 ugnetto 150 mm	36
14 chiavi combinate 6+14 - 17 - 19 - 21 - 22 - 24 mm	42
9 chiavi maschio esagonali piegate 1,5 - 2 - 2,5 - 3 - 4 - 5 - 6 - 8 - 10 mm	96/SP9
1 chiavi regolabili a rullino 250 mm	110
1 pinza regolabile cerniera chiusa 240 mm	1048
1 tronchese a taglienti diagonali 160 mm	1082
1 forbici per elettricisti lame diritte	1128BMX
1 pinza universale 180 mm	1150
1 pinza a becchi mezzotondi dritti 160 mm	1166
4 giravite lama piatta 3x75 - 4x100 - 5,5x100 - 6,5x150 mm	1201
3 giravite Phillips® PH0x60 - PH1x80 - PH2x100 mm	1202
1 martello tipo tedesco 300 g	1370
1 flessometro 5 m	1691A/5
1 cutter con lama a settori	1771

5915U2

 059150064



2110U2

(C10+5915U2)

021100052



2115U2

(C15+5915U2)

021150052



2115L/U2

(C15L+5915U2)

021150112



2116P/U2

(CP16+5915U2)

021160052



2117P/U2

(CP17+5915U2)

021170052



2117PL/U2

(CP17L+5915U2)

021170112



2118/U2

(C18+5915U2)

021180052

5915U3

Assortimento di 75 utensili

Universali



8,1 kg

N. pezzi/Descrizione

N. pezzi/Descrizione	Beta N.
1 cacciapina Ø 4 mm	31
1 bulino Ø 4 mm	32
1 scalpello piatto normale 150 mm	34
15 chiavi combinate 6+17 - 19 - 22 - 24 mm	42
9 chiavi maschio esagonale piegate con supporto plastico 1,5+10 mm	96/SP9
3 chiavi maschio esagonale con impugnatura 4 - 5 - 6 mm	96T
1 chiave regolabile a rullino 250 mm	110
13 chiavi a bussola esagonali 1/2" 8+17 - 19 - 22 - 24 mm	920A
1 prolunga 255 mm - 1/2"	920/22
1 snodo 1/2"	920/25
1 quadro maschio 1/2" con spina scorrevole	920/42
1 cricchetto reversibile 1/2"	920/55
7 chiavi a tubo doppie serie leggera	935
6x7 - 8x9 - 10x11 - 12x13 - 14x15 - 16x17 - 18x19 mm	
2 spine di manovra per chiavi a tubo 1 - 2	940
1 pinza regolabile cerniera a cremagliera 240 mm	1048V
1 pinza regolabile autobloccante 240 mm	1052
1 tronchese a grande effetto taglienti diagonali 160 mm	1084BM
1 forbici per elettricisti lame diritte	1128BMX
1 pinza universale 180 mm	1150BM
1 pinza a becchi mezzotondi diritti 160 mm	1166BM
4 giravite lama piatta 3x75 - 4x100 - 5,5x150 - 6,5x150 mm	1201
3 giravite Phillips® PH0x60 - PH1x80 - PH2x100 mm	1202
1 martello tipo tedesco 400 g	1370
1 flessometro 5 m	1691A/5
1 seghetto	1726
1 oliatore in plastica 150 cc	1755
1 cutter con lama a settori	1771

5915U3 059150066



2110U3
(C10+5915U3) 021100073



2115U3
(C15+5915U3) 021150173



2115L/U3
(C15L+5915U3) 021150123



2116P/U3
(CP16+5915U3) 021160073



2117P/U3
(CP17+5915U3) 021170073



2117PL/U3
(CP17L+5915U3) 021170123



2119/U3
(C19+5915U3) 021190073



2119L/U3
(C19L+5915U3) 021190093



2120U3
(C20+5915U3) 021200073



2120L/U3
(C20L+5915U3) 021200093



4100S/U3
(C41S+5915U3) 041000051



4100H/U3
(C41H+5915U3) 041000061

5915U5

Assortimento di 49 utensili

Universali



N. pezzi/Descrizione

- 8 chiavi a forchetta 6x7 - 8x9 - 10x11 - 12x13 - 14x15 - 16x17 - 18x19 - 20x22 mm
- 9 chiavi maschio esagonale piegate 1,5 - 2 - 2,5 - 3 - 4 - 5 - 6 - 8 - 10 mm
- 13 chiavi a bussola esagonali 1/4" 4+14 mm
- 1 prolunga 150 mm - 1/4"
- 1 snodo 1/4"
- 1 quadro con impugnatura 1/4"
- 1 quadro scorrevole 1/4"
- 1 cricchetto reversibile 1/4"
- 1 pinza regolabile cerniera chiusa 240 mm
- 1 forbici per elettricisti lame dritte
- 1 pinza universale 180 mm
- 4 giravite lama piatta 3x75 - 4x125 - 6,5x150 mm
- 3 giravite Phillips® PH1x80 - PH2x100 mm
- 1 martelli tipo tedesco 300 - 600 g
- 1 flessometro 3 m
- 1 oliatore in plastica 30 cc
- 1 cutter con lama a settori 18 mm

Beta N.

- 55/B8
- 96/SP9
- 900
- 900/21
- 900/25
- 900/30
- 900/42
- 900/55
- 1048
- 1128BM
- 1150
- 1201
- 1202
- 1370
- 1692B/3
- 1755
- 1771

5915U5 059150067



2014N/U5 (2014N/VV+5915U5) 020140190



2034/U5 (2034/VV+5915U5) 020340060

5915U/AS1

Assortimento di 71 utensili

Universali



N. pezzi/Descrizione

- 1 cacciaspina Ø 4 mm
- 1 bulino Ø 4 mm
- 1 scalpello piatto normale 150 mm
- 13 chiavi combinate 1/4 - 5/16 - 3/8 - 7/16 - 1/2 - 9/16 - 5/8 - 11/16 - 3/4 - 13/16 - 7/8 - 15/16 - 1"
- 8 chiavi poligonali curve 1/4" + 1"
- 11 chiavi maschio esagonale piegate in busta 3/64" + 3/8"
- 1 chiave regolabile a rullino 250 mm
- 13 chiavi a bussola poligonali □ 1/2", 3/8 - 7/16 - 1/2 - 9/16 - 5/8 - 19/32 - 11/16 - 3/4 - 25/32 - 13/16 - 7/8 - 15/16 - 1"
- 1 prolunga 255 mm - 1/2"
- 1 snodo 1/2"
- 1 quadro maschio 1/2" con spina scorrevole
- 1 cricchetto reversibile 1/2"
- 1 pinza regolabile cerniera chiusa 240 mm
- 1 pinza regolabile autobloccante 240 mm
- 1 tronchese a grande effetto taglienti diagonali 160 mm
- 1 forbici per elettricisti lame dritte
- 1 pinza universale 180 mm
- 1 pinza a becchi mezzotondi dritti 160 mm
- 4 giravite lama piatta 3x75 - 4x100 - 5,5x150 - 6,5x150 mm
- 3 giravite Phillips® PH0x60 - PH1x80 - PH2x100 mm
- 1 martello tipo tedesco 400 g
- 1 flessometro 5 m
- 1 seghetto
- 1 oliatore in plastica 150 cc
- 1 cutter con lama a settori

Beta N.

- 31
- 32
- 34
- 42AS
- 90AS/8
- 96AS/B11
- 110
- 920AS
- 920/22
- 920/25
- 920/42
- 920/50
- 1048V
- 1052
- 1084BM
- 1128BMX
- 1150BM
- 1166BM
- 1201
- 1202
- 1370
- 1691A/5
- 1726
- 1755
- 1771

9,3 kg

5915U/AS1 059150071



2110U/AS1 (C10+5915U/AS1) 021100075



2116PU/AS1 (CP16+5915U/AS1) 021160075



2120U/AS1 (C20+5915U/AS1) 021200075



2120LU/AS1 (C20L+5915U/AS1) 021200095

5915U/FR

Assortimento di 80 utensili

Universali



11,2 kg

5915U/FR 059150085



2116PU/FR (CP16+5915U/FR) 021160077



2120U/FR (C20+5915U/FR) 021200077



2120LU/FR (C20L+5915U/FR) 021200097

N. pezzi/Descrizione

N. pezzi/Descrizione	Beta N.
1 cacciapina Ø 4 mm	31
1 bulino Ø 4 mm	32
1 scalpello piatto normale 150 mm	34
15 chiavi combinate 6+17 - 19 - 22 - 24 mm	42
9 chiavi maschio esagonale piegate 1,5+10 mm	96/SP9
1 chiave regolabile a rullino 250 mm	110
13 chiavi a bussola esagonali 1/2" 8+17 - 19 - 22 - 24 mm	920A
1 prolunga 255 mm - 1/2"	920/22
1 snodo 1/2"	920/25
1 quadro maschio 1/2" con spina scorrevole	920/42
1 cricchetto reversibile 1/2"	920/55
17 chiavi a pipa doppie esagonali - poligonali 6+22 mm	932/S17
1 pinza regolabile cerniera chiusa 240 mm	1048
1 pinza regolabile autobloccante 240 mm	1052
1 tronchese a grande effetto taglienti diagonali 160 mm	1084BM
1 forbici per elettricisti lame diritte	1128BMX
1 pinza universale 180 mm	1150BM
1 pinza a becchi mezzotondi diritti 160 mm	1166BM
4 giravite lama piatta 3x75 - 4x100 - 5,5x150 - 6,5x150 mm	1201
3 giravite Phillips® PH0x60 - PH1x80 - PH2x100 mm	1202
1 martello tipo francese 32 mm	1370F
1 flessometro 5 m	1691A/5
1 seghetto	1726
1 oliatore in plastica 150 cc	1755
1 cutter con lama a settori	1771

5938U/1

Assortimento di 160 utensili

Universali



18,9 kg

5938U/1 059380040



3800 O/U1 (C38 O+5938U/1) 038000041



3800 G/U1 (C38 G+5938U/1) 038000043



3800 R/U1 (C38 R+5938U/1) 038000042

N. pezzi/Descrizione

N. pezzi/Descrizione	Beta N.
1 punzoni Ø 3 mm	31
1 cacciapina Ø 4 mm	31
1 bulino Ø 4 mm	32
2 scalpelli piatti nervati 100 - 200 mm	35
17 chiavi combinate 6 - 7 - 8 - 10 - 11 - 12 - 13 - 14 - 16 - 17 - 18 - 19 - 21 - 22 - 24 - 27 - 30 mm	42
8 chiavi a forchetta 6x7 - 8x9 - 10x11 - 12x13 - 14x15 - 16x17 - 18x19 - 20x22 mm	55
18 chiavi maschio esagonali piegate 1,5+10 mm	96/SP9
11 chiavi maschio esagonale con impugnatura 2 - 2,5 - 3 - 3,5 - 4 - 4,5 - 5 - 6 mm	96T
17 chiavi a bussola esagonali 3/8" 6+22 mm	910A
1 prolunga 125 mm - 3/8"	910/21
1 prolunga 250 mm - 3/8"	910/22
1 snodo 3/8"	910/25
1 quadro maschio 3/8" con spina scorrevole	910/42
1 cricchetto reversibile 3/8"	910/55
11 chiavi a bussola esagonali 1/2" 10 - 11 - 12+19 - 20 - 21 - 22 - 23 - 24 - 26 - 27 - 30 - 32 mm	920A
5 chiavi a bussola maschio esagonale 1/2" 5 - 6 - 8 - 10 - 12 mm	920ME
1 prolunga 125 mm - 1/2"	920/21
1 prolunga 255 mm - 1/2"	920/22
1 snodo 1/2"	920/25
1 quadro maschio 1/2" con spina scorrevole	920/42
1 cricchetto reversibile 1/2"	920/55
6 chiavi a T maschio esagonale 2,5 - 3 - 4 - 5 - 6 - 8 mm	951
1 pinza becchi dritti per anelli elastici, per fori 180 mm	1032
1 pinza becchi piegati per anelli elastici, per fori 170 mm	1034
1 pinza becchi dritti per anelli elastici, per alberi 175 mm	1036
1 pinza becchi piegati per anelli elastici, per alberi 175 mm	1038
1 pinza regolabile cerniera chiusa 240 mm	1048
1 pinza regolabile autobloccante 240 mm	1052
1 tronchese a grande effetto taglienti diagonali 160 mm	1084BM
1 pinza universale 180 mm	1150BM
1 pinza a becchi mezzotondi diritti 160 mm	1166BM
7 giravite lama piatta 2,5x50 - 3x75 - 3,5x100 - 4x125 - 5,5x100 - 5,5x150 - 6,5x150 mm	1201
6 giravite Phillips® PH0x60 - PH1x80 - PH1x120 - PH2x100 - PH2x150 - PH3x150 mm	1202
7 chiavi maschio con impugnatura per viti con impronta Torx® T6 - T7 - T8 - T9 - T10 - T15 - T20	1207TX
1 martello tipo tedesco 300 g	1370
1 mazzuola con battente in materiale plastico Ø 35 mm	1390
1 calibro a corsoio	1650
1 riga flessibile graduata 300 mm	1682
1 flessometro 5 m	1692B/5
1 contafiletto	1707
1 spessimetro	1708/20
5 lime a taglio mezzodolce 200 mm	1719BMA/S5
1 miniseghetto	1725CR
1 oliatore in plastica	1755
1 cutter	1771
4 termoformati vuoti	VP3-SC
4 termoformati vuoti	VP-LS
4 termoformati vuoti	VP-LD
1 termoformato vuoto	VP1

5957U/2

Assortimento di 132 utensili

Universali



21,3 kg

5957U/2 059570160



5700P O/U2 (C57P O+5957U/2) 057000079



5700P G/U2 (C57P G+5957U/2) 057000279



5700P R/U2 (C57P R+5957U/2) 057000479

N. pezzi/Descrizione

- 6 cacciaspina con supporto Ø 2 - 3 - 4 - 5 - 6 - 8 mm
- 2 punzoni, 1 bulino, 3 scalpelli con supporto
- 19 chiavi combinate 6+22 - 24 - 27 mm
- 12 chiavi poligonali curve 6x7+30x32 mm
- 12 chiavi maschio esagonale piegate 2+10 mm
- 1 chiave regolabile a rullino 250 mm
- 13 chiavi a bussola poligonali 1/2" con guida 10+22 mm
- 8 chiavi a bussola poligonali 1/2" con guida 23+32 mm
- 4 chiavi a bussola a giravite lama piatta 1/2" 1,2x6,5 - 1,2x8 - 1,6x9 - 2x12 mm
- 3 chiavi a bussola a giravite lama Phillips® 1/2" PH2 - 3 - 4
- 1 prolunga 125 mm - 1/2"
- 1 prolunga 255 mm - 1/2"
- 1 snodo 1/2"
- 1 quadro maschio snodato 1/2" con impugnatura
- 1 quadro maschio 1/2" con spina scorrevole
- 1 cricchetto reversibile 1/2"
- 1 leva con estremità a punta e piatta curva
- 1 pinzetta punte fini curve 120 mm
- 1 pinzetta punte larghe diritte 150 mm
- 1 pinza becchi dritti per anelli elastici, per fori 180 mm
- 1 pinza becchi piegati per anelli elastici, per fori 170 mm
- 1 pinza becchi dritti per anelli elastici, per alberi 175 mm
- 1 pinza becchi piegati per anelli elastici, per alberi 175 mm
- 1 pinza regolabile cerniera chiusa 240 mm
- 1 pinza autobloccante a doppia regolazione
- 1 tronchese a grande effetto taglienti diagonali 160 mm
- 1 tronchese doppia leva taglio frontale 180 mm
- 1 cesoia a lame larghe diritte 250 mm
- 1 cesoia a lame strette diritte 200 mm
- 1 forbici per elettricisti lame diritte
- 1 pinza universale 180 mm
- 1 pinza a becchi mezzotondi dritti 160 mm
- 1 pinza a becchi mezzotondi piegati 200 mm
- 7 giravite lama piatta 3x75 - 3,5x100 - 4x125 5,5x150 - 6,5x200 - 10x200 - 12x250 mm
- 1 giravite lama piatta con esagono di manovra 12x200 mm
- 3 giravite Phillips® PH0x60 - PH1x80 - PH2x100 mm
- 2 martelli tipo tedesco 300 - 600 g
- 1 mazzuola con battente in materiale plastico Ø 35 mm
- 1 flessometro 5 m
- 1 flessibile magnetico 1,8 kg
- 1 raschietto a due taglienti 200 mm
- 1 raschietto a tre taglienti 200 mm
- 5 lime taglio mezzodolce 200 mm
- 1 seghetto
- 1 oliatore in metallo a pressione 200 cc

Beta N.

- 31/SP6
- 38/SP6
- 42
- 90/S12X
- 96/SP12
- 110
- 920B/SB13
- 920B/SB8
- 920LP
- 920PH
- 920/21
- 920/22
- 920/25
- 920/35A
- 920/42
- 920/55
- 963
- 991
- 994
- 1032
- 1034
- 1036
- 1038
- 1048
- 1051
- 1084BM
- 1092V
- 1112
- 1114
- 1128BMX
- 1150BM
- 1166BM
- 1168BM
- 1270
- 1270E
- 1272
- 1370
- 1390
- 1691A/5
- 1712E/2
- 1717A
- 1717B
- 1719BMA/S5
- 1725
- 1751

5958U/2

Assortimento di 86 utensili

Universali



11,3 kg

5958U/2 059580140



5800A/U2 (C58A+5958U/2) 058000081



5800B/U2 (C58B+5958U/2) 058000082



5800P/AU2 (C58P/A+5958U/2) 058000086



5800P/BU2 (C58P/B+5958U/2) 058000087

N. pezzi/Descrizione

- 18 chiavi combinate 5,5+22 mm
- 12 chiavi maschio esagonale piegate 2+10 mm
- 13 chiavi a bussola esagonali 1/2" con guida 10+22 mm
- 8 chiavi a bussola esagonali 1/2" con guida 23+32 mm
- 1 prolunga 125 mm - 1/2"
- 1 prolunga 255 mm - 1/2"
- 1 snodo 1/2"
- 1 quadro maschio 1/2" con spina scorrevole
- 1 cricchetto reversibile 1/2"
- 1 pinza becchi dritti per anelli elastici, per fori 180 mm
- 1 pinza becchi dritti per anelli elastici, per alberi 175 mm
- 1 pinza regolabile cerniera chiusa 240 mm
- 1 pinza regolabile autobloccante 240 mm
- 1 tronchese a grande effetto taglienti diagonali 160 mm
- 1 forbici per elettricisti lame diritte
- 1 pinza universale 180 mm
- 1 pinza a becchi mezzotondi dritti 160 mm
- 7 giravite lama piatta 3x75 - 3,5x100 - 4x125 5,5x150 - 6,5x150 - 8x200 - 10x200 mm
- 4 giravite Phillips® PH0x60 - PH1x80 PH2x100 - PH3x150 mm
- 1 martello tipo tedesco 300 g
- 1 mazzuola con battente in materiale plastico Ø 35 mm
- 1 flessometro 5 m
- 5 lime taglio mezzodolce 200 mm
- 1 seghetto
- 1 oliatore in plastica a pressione 150 cc
- 1 cutter con lama a settori

Beta N.

- 42
- 96N/SP12
- 920A/SB13
- 920A/SB8
- 920/21
- 920/22
- 920/25
- 920/42
- 920/55
- 1032
- 1036
- 1048
- 1052
- 1084BM
- 1128BMX
- 1150BM
- 1166BM
- 1270
- 1272/S4
- 1370
- 1390
- 1691A/5
- 1719BMA/S5
- 1725
- 1754
- 1771

5980E/1A

Assortimento di 58 utensili

Elettrotecnica



6,8 kg

5980E/1A	059800311
----------	-----------



2011E/1A (2011/BV+5980E/1A)	020110170
--------------------------------	-----------



2032E/1A (2032/VV+5980E/1A)	020320071
--------------------------------	-----------



2034E/1A (2034/VV+5980E/1A)	020340040
--------------------------------	-----------

N. pezzi/Descrizione

N. pezzi/Descrizione	Beta N.
2 cacciapina Ø 4 - 6 mm	31
1 bulino Ø 4 mm	32
2 scalpelli piatti nervati 125 - 200 mm	35
8 chiavi a forchetta 6x7 - 8x9 - 10x11 - 12x13 - 14x15 - 16x17 - 18x19 - 20x22 mm	55/B8
10 chiavi maschio esagonale piegate 1,5÷12 mm	96/B10
1 chiave regolabile a rullino 200 mm	110
1 pinza regolabile cerniera a cremagliera 240 mm	1046
1 tronchese a taglienti diagonali 160 mm	1082BM
1 forcipi per elettricisti lame dritte	1128BMX
1 tagliacavo 170 mm	1132BM
1 pinza spellafili 160 mm	1142BM
1 pinza universale 180 mm	1150BM
1 pinza a becchi mezzotondi dritti 160 mm	1166BM
1 pinza a becchi mezzotondi piegati 160 mm	1168BM
1 giravite prensile lama piatta 4x125 mm	1250
1 giravite prensile Phillips® PH1x150 mm	1251
1 giravite cercafase	1260
5 giravite lama piatta	1270
2,5x75 - 3,5x100 - 5,5x150 - 8x200 - 12x250 mm	
2 giravite nani lama piatta 4x30 - 6,5x30 mm	1270N
1 giravite nano Phillips® PH2x30 mm	1272N
3 giravite lama Phillips® 1000V	1272MQ
PH1x80 - PH2x100 - PH3x150 mm	
4 giravite lama parallela 1000V	1274MQ
3x100 - 4x100 - 6,5x150 - 8x175 mm	
1 martello tipo tedesco 300 g	1370
1 mazzuola con battente in materiale plastico Ø 35 mm	1390
1 pinza per capicorda preisolati	1602
1 flessometro 5 m	1691A/5
1 lima taglio mezzodolce 200 mm	1719BMA/M
1 lima taglio mezzodolce 200 mm	1719BMA/R
1 seghetto	1725
1 coltello a serramanico	1777BM

5980E/2A

Assortimento di 69 utensili

Elettrotecnica



3,7 kg

5980E/2A	059800312
----------	-----------



2011E/2A (2011/BV+5980E/2A)	020110180
--------------------------------	-----------



2029E/2A (2029/VV+5980E/2A)	020290110
--------------------------------	-----------



2033E/2A (2033N/VV+5980E/2A)	020330060
---------------------------------	-----------



2036E/2A (2036/TV+5980E/2A)	020360022
--------------------------------	-----------

N. pezzi/Descrizione

N. pezzi/Descrizione	Beta N.
3 cacciapina Ø 2 - 3 - 4 mm	31
1 bulino Ø 4 mm	32
1 scalpello piatto normale 150 mm	34
8 chiavi a forchetta 6x7 - 8x9 - 10x11 - 12x13 - 14x15 - 16x17 - 18x19 - 20x22 mm	55/B8
9 chiavi maschio esagonale piegate con estremità sferica	96BPC/SP9
1,5 - 2 - 2,5 - 3 - 4 - 5 - 6 - 8 - 10 mm	
1 sbavatore a raschietto 150 mm	345SB
6 chiavi a bussola esagonale con impugnatura 1000V 5,5 - 6 - 7 - 8 - 10 - 13 mm	943MQ/S6
1 pinza regolabile cerniera chiusa 240 mm	1048
1 tronchese a taglienti diagonali 1000V 160 mm	1082MQ
1 forcipi per elettricisti lame dritte	1128BMX
1 tagliacavo 230 mm	1132BM
1 pinza spellafili 160 mm	1142BM
1 pinza universale 1000V 180 mm	1150MQ
1 pinza a becchi mezzotondi dritti 160 mm	1166BM
1 giravite cercafase	1260
2 giravite nani lama piatta 4x30 - 6,5x30 mm	1270N
1 giravite nano Phillips® PH2x30 mm	1272N
3 giravite lama Phillips® 1000V	1272MQ
PH0x60 - PH1x80 - PH2x100 mm	
4 giravite lama parallela 1000V	1274MQ
3x100 - 4x100 - 5,5x125 - 6,5x150 mm	
1 martello tipo tedesco 300 g	1370
1 mazzuola con battente in materiale plastico Ø 35 mm	1390
1 pinza per capicorda preisolati	1602
1 riga flessibile graduata 250 mm	1682
1 punta per tracciare 220 mm	1688
1 flessometro 5 m	1691A/5
1 livella in alluminio 200 mm	1696
1 scalpello per elettricisti 10x200 mm	1701NE/3
1 traccialinea	1705
1 specchietto flessibile 600 mm	1715FL/A
1 lima taglio mezzodolce 200 mm	1719BMA/M
1 lima taglio mezzodolce 200 mm	1719BMA/R
1 tenditore per molle	1723
1 seghetto	1726BM
1 pennello	1738
1 pinza per collari in Nylon	1743
1 oliatore in plastica 100 cc	1755
1 collari in Nylon 3,6x200 mm (100 pz)	1748/BK
1 collari in Nylon 4,8x300 mm (100 pz)	1748/17K
1 cutter	1771BM
1 saldatore 20/40W	1816A
1 torcetta	1835

5980MQ/1

Assortimento di 44 utensili

Elettrotecnica



N. pezzi/Descrizione

- 7 chiavi a forchetta 1000V 10-12-13-14-17-19-22 mm
- 1 chiave regolabile a rullino 1000V 250 mm
- 6 chiavi a bussola esagonale con impugnatura 5,5 - 6 - 7 - 8 - 10 - 13 mm
- 4 chiavi a T maschio esagonale 4-5-6-8 mm
- 1 pinzetta a molla a punte curve arrotondate 1000V 147 mm
- 1 pinze a becchi tondi lunghi 160 mm
- 1 tronchesi a taglienti diagonali 1000V 160 mm
- 1 forbici per elettricisti lame dritte
- 1 pinze spellafili 160 mm
- 1 pinza universale 180 mm
- 1 pinze a becchi mezzotondi lunghissimi 1000V 160 mm
- 1 giravite cercafase
- 3 giravite Phillips® 1000V PH1x80 - PH2x100 - PH3x150 mm
- 5 giravite a lama parallela 1000V 3x100 - 4x100 - 5,5x125 - 6,5x150 - 8x175 mm
- 3 giravite Pozidrive® 1000V PZ0-PZ1-PZ2
- 1 mazzuola con battente in materiale plastico Ø 35 mm
- 1 specchio
- 1 miniseghetto 1000V
- 1 cutter 1000V
- 1 saldatore a doppia potenza 20-40 W
- 1 pompetta succhiastagno
- 1 tester combinato di tensione e di continuità

Beta N.

- 52MQ
- 110MQ
- 943MQ
- 951MQ
- 993MQ
- 1010MQ
- 1082MQ
- 1128BM
- 1142MQ
- 1150MQ
- 1166MQ
- 1260
- 1272MQ
- 1274MQ
- 1279MQ
- 1390
- 1714
- 1725MQ
- 1777MQ
- 1816A
- 1830
- 1847

5980MQ/1

059800313



2031MQ/1

(2031/VV+5980MQ/1)

020310150

5980E/6

Assortimento di 98 utensili

Elettronica



N. pezzi/Descrizione

- 13 chiavi a forchetta piccole 4+14 mm
- 9 chiavi maschio esagonali piegate 1,5+10 mm
- 8 chiavi maschio con impronta Torx® T9 - T10 - T15 - T20 - T25 - T27 - T30 - T40
- 1 chiave regolabile a rullino 150 mm
- 18 assortimento 13 bussole e 5 accessori 1/4"
- 1 pinzetta a molla a punte fini diritte 130 mm
- 1 pinzetta punte fini curve 130 mm
- 1 pinzetta a molla a punte corte finissime 130 mm
- 1 forbici per elettricisti lame dritte
- 1 pinza spellafili frontale autoregolabile 170 mm
- 1 pinza universale 180 mm
- 1 pinza a becchi piatti lunghi
- 1 pinza a becchi mezzotondi lunghi lisci
- 1 pinza a becchi mezzotondi lunghi piegati
- 1 tronchese a taglienti diagonali rasi becchi arrotondati
- 1 tronchese a taglienti diagonali rasi becchi assotigliati
- 1 tronchese a taglienti frontali obliqui rasi
- 8 microgiravite per viti a testa con intaglio e Phillips®
- 1 giravite cercafase
- 1 giravite nano lama piatta 6,5x30 mm
- 1 giravite Phillips® PH0x60 - PH1x80 - PH2x100 mm
- 2 giravite nano Phillips® PH1x30 - PH2x30 mm
- 5 giravite lama parallela 2,5x60 - 3x75 - 4x100 - 5x125 - 6,5x150 mm
- 1 martello tipo tedesco 200 g
- 1 riga flessibile graduata 150 mm
- 1 punta per tracciare 220 mm
- 1 flessometro 5 m
- 1 specchio telescopico 670 mm
- 1 lime ad ago ●
- 1 lime ad ago ▲
- 1 lime ad ago ▮
- 1 tenditore per molle
- 1 pennello
- 1 oliatore a stilo
- 1 cutter
- 1 coltello a serramanico
- 1 pinzetta autobloccante
- 1 saldatore 20/40W
- 1 pompetta succhiastagno
- 1 torcetta

Beta N.

- 73/B13
- 96/SP9
- 97TX/PL8
- 110
- 900/C13-5
- 990
- 991
- 999A
- 1128BMX
- 1149F
- 1150BM
- 1172BM
- 1177BM
- 1178BM/P
- 1184BM
- 1186BM
- 1191BM
- 1255LPH/S8
- 1260
- 1290N
- 1292
- 1292N
- 1294
- 1370
- 1682
- 1688
- 1691A/5
- 1715
- 1720R
- 1720T
- 1720P
- 1723
- 1738
- 1756
- 1771BM
- 1777BM
- 1779
- 1816A
- 1830
- 1835

4,8 kg

5980E/6

059800306



2029E/6

(2029/VV+5980E/6)

020290115



2031E/6

(2031/VV+5980E/6)

020310051



2033E/6

(2033N/VV+5980E/6)

020330040



2036E/6

(2036/TV+5980E/6)

020360026

5980E/7

Assortimento di 57 utensili

Electronica



📦 2,6 kg

5980E/7

059800307



2031E/7

(2031/VV+5980E/7)

020310050



2032E/7

(2032/VV+5980E/7)

020320061

N. pezzi/Descrizione

- 13 chiavi a forchetta piccole 4+14 mm
- 9 chiavi maschio esagonale piegate bruite 1,5+10 mm
- 1 pinzetta punte fini curve 130 mm
- 1 pinzetta punte fini dritte 150 mm
- 1 pinzetta becchi dritti incrociati 155 mm
- 1 forbici per elettricisti, lame dritte
- 1 pinza spellafili 160 mm
- 1 pinza a becchi mezzotondi dritti 160 mm
- 1 pinza a becchi piatti lunghi
- 1 pinza a becchi mezzotondi corti piegati
- 1 pinza universale per elettronica
- 1 tronchese a taglienti diagonali rasi
- 1 tronchese a taglienti diagonali normali
- 1 giravite prensile lama piatta 4x125 mm
- 1 giravite prensile Phillips® PH0x125 mm
- 8 microgiravite per viti a testa con intaglio e Phillips®
- 1 martello tipo tedesco 200 g
- 1 flessometro 5 m
- 1 specchietto telescopico
- 3 lime ad ago
- 1 tenditore per molle
- 1 pennello
- 1 oliatore a stilo
- 1 cutter lama a settori
- 1 pinzetta autobloccante
- 1 saldatore 40 W
- 1 pompetta succhiastagno
- 1 torcetta

Beta N.

- 73/B13
- 96N/SP9
- 991
- 992
- 998
- 1128BMX
- 1142BM
- 1166BM
- 1172BM
- 1178BM/P
- 1178BM
- 1185BM/1
- 1188BM/1
- 1250
- 1251
- 1255LPH/S8
- 1370
- 1691A/5
- 1715
- 1720/S3
- 1723
- 1738
- 1756
- 1771
- 1779
- 1814
- 1830
- 1835

5980I/1

Assortimento di 35 utensili

Idraulica



📦 11,6 kg

5980I/1

059800221



2009I/1

(2009N/BV+5980I/1)

020090021

N. pezzi/Descrizione

- 1 scalpello piatto normale 150 mm
- 1 scalpello piatto nervato 200 mm
- 12 chiavi a forchetta 6x7 - 8x9 - 10x11 - 12x13 - 14x15 - 16x17 - 18x19 - 20x22 - 21x23 - 24x27 - 25x28 - 30x32 mm
- 1 chiave regolabile a rullino 250 mm
- 1 tagliatubi per rame e leghe leggere Ø 3+30 mm
- 1 giratubi modello svedese 320 mm
- 1 pinza regolabile cerniera chiusa 240 mm
- 1 pinza regolabile autobloccante 240 mm
- 1 cesoia a lame larghe dritte 300 mm
- 1 forbici per elettricisti lame dritte
- 1 pinza universale 180 mm
- 4 giravite lama piatta 3x75 - 4x100 - 5,5x150 - 8x150 mm
- 2 giravite Phillips® PH1x80 - PH2x100 mm
- 1 martello tipo tedesco 300 g
- 1 metro pieghevole in fibra 2 m
- 1 flessometro 5 m
- 1 livella in alluminio 200 mm
- 1 lima taglio mezzodolce 200 mm
- 1 seghetto
- 1 spazzola fili d'acciaio

Beta N.

- 34
- 35
- 55/S12X
- 110
- 334
- 374
- 1048
- 1052
- 1112
- 1128BMX
- 1150BM
- 1201
- 1202
- 1370
- 1690F
- 1691A/5
- 1696A
- 1719BMA/M
- 1725
- 1737NX

5902MT/1

Assortimento di 106 utensili per macchine agricole, edili e movimento terra

Autoriparazione



28,6 kg

N. pezzi/Descrizione

Beta N.

2	punzoni Ø 3 - 4 mm	30
2	cacciaspina Ø 6 - 8 mm	31
1	bulino Ø 4 mm	32
2	scalpelli piatti nervati 150 - 200 mm	35
18	chiavi combinate 6+14 - 17 - 19 - 22 - 24 - 27 - 30 - 32 - 36 - 41 mm	42
10	chiavi poligonali curve 6x7 - 8x9 - 10x11 - 12x13 - 14x15 - 16x17 18x19 - 20x22 - 24x27 - 30x32 mm	90
10	chiavi maschio esagonale piegate 1,5+12 mm	96N/B10
17	chiavi a bussola esagonali 1/2", 10+22 - 24 - 27 - 30 - 32 mm	920A
1	prolunga 125 mm - 1/2"	920/21
1	prolunga 255 mm - 1/2"	920/22
1	snodo 1/2"	920/25
1	quadro maschio 1/2" con spina scorrevole	920/42
1	cricchetto con quadro scorrevole 1/2"	920/50
11	chiavi a bussola esagonali 3/4", 22 - 24 - 27 - 30 - 32 - 36 - 41 - 46 - 50 - 55 - 60 mm	928A
1	prolunga 200 mm - 3/4"	928/21
1	quadro maschio snodato 3/4" con impugnatura	928/36A
1	quadro maschio 3/4" con spina scorrevole	928/42
1	cricchetto reversibile 3/4"	928/55
1	leva con estremità a punta e a becco	964
1	pinza regolabile cerniera chiusa 240 mm	1048
1	pinza autobloccante ganasce sagomate	1055
1	tronchese a grande effetto taglienti diagonali 160 mm	1084BM
1	forbici per elettricisti lame dritte	1128BMX
1	pinza universale 180 mm	1150BM
1	pinza a becchi mezzotondi dritti 160 mm	1166BM
4	giravite lama piatta con esagono di manovra 5,5x125 - 6,5x150 - 10x175 - 12x200 mm	1270E
3	giravite Phillips® con esagono di manovra PH2x150 - PH3x175 - PH4x200 mm	1272E
1	martello testa tonda penna sferica 900 g	1377
1	mazzuola con battente in materiale plastico Ø 35 mm	1390
1	spessimetro a 20 lame	1708/20
1	raschietto a tre taglienti 200 mm	1717B
5	lime taglio mezzodolce 200 mm	1719BMA/S5
1	seghetto	1725

5902MT/1

059020023



2200 O/MT1

(C22 O+5902MT/1)

022000362



2200 G/MT1

(C22 G+5902MT/1)

022000367



2200 R/MT1

(C22 R+5902MT/1)

022000369



2300 O/MT1

(C23 O+5902MT/1)

023000362



2300 G/MT1

(C23 G+5902MT/1)

023000367



2300 R/MT1

(C23 R+5902MT/1)

023000369



2300C O/MT1

(C23C O+5902MT/1)

023000382



2300C G/MT1

(C23C G+5902MT/1)

023000387



2300C R/MT1

(C23C R+5902MT/1)

023000389

5902MT1/AS

Assortimento di 99 utensili per macchine movimento terra (CATERPILLAR)

Autoriparazione



27,3 kg

5902MT1/AS 059020024



2200 O/MT1AS
(C22 O+5902MT1/AS) 022000343



2200 G/MT1AS
(C22 G+5902MT1/AS) 022000348



2200 R/MT1AS
(C22 R+5902MT1/AS) 022000339



2300 O/MT1AS
(C23 O+5902MT1/AS) 023000333



2300 G/MT1AS
(C23 G+5902MT1/AS) 023000338



2300 R/MT1AS
(C23 R+5902MT1/AS) 023000339

N. pezzi/Descrizione

N. pezzi/Descrizione	Beta N.
2 punzoni Ø 3 - 4 mm	30
2 cacciaspina Ø 6 - 8 mm	31
1 bulino Ø 4 mm	32
2 scalpelli piatti nervati 150 - 200 mm	35
20 chiavi combinate 1/4+1.1/2"	42AS
6 chiavi poligonali curve 1/4x5/16 - 3/8x7/16 - 1/2x9/16 5/8x3/4 - 11/16x13/16 - 7/8x15/16"	90AS
11 chiavi maschio esagonale piegate 3/64+3/8"	96AS/B11
10 chiavi a bussola poligonali □ 1/2", 7/16 - 1/2 - 9/16 5/8 - 11/16 - 3/4 - 13/16 - 7/8 - 15/16 - 1"	920AS
1 prolunga 125 mm - 1/2"	920/21
1 prolunga 255 mm - 1/2"	920/22
1 snodo 1/2"	920/25
1 quadro maschio 1/2" con spina scorrevole	920/42
1 cricchetto con quadro scorrevole 1/2"	920/50
12 chiavi a bussola esagonali □ 3/4", 7/8 - 15/16 - 1 - 1.1/16 - 1.1/8 - 1.1/4 - 1.5/16 1.1/2 - 1.5/8 - 1.11/16 - 1.7/8 - 2"	928AS
1 prolunga 200 mm - 3/4"	928/21
1 quadro maschio snodato 3/4" con impugnatura	928/36A
1 quadro maschio 3/4" con spina scorrevole	928/42
1 cricchetto reversibile 3/4"	928/55
1 leva con estremità a punta e a becco	964
1 pinza regolabile cerniera chiusa 240 mm	1048
1 pinza autobloccante ganasce sagomate	1055
1 tronchese a grande effetto taglienti diagonali 160 mm	1084BM
1 forbici per elettricisti lame dritte	1128BMX
1 pinza universale 180 mm	1150BM
1 pinza a becchi mezzolondi diritti 160 mm	1166BM
4 giravite lama piatta con esagono di manovra 5,5x125 - 6,5x150 - 10x175 - 12x200 mm	1270E
3 giravite Phillips® con esagono di manovra PH2x150 - PH3x175 - PH4x200 mm	1272E
1 martello testa tonda penna sferica 900 g	1377
1 mazzuola con battente in materiale plastico Ø 35 mm	1390
1 spessimetro a 20 lame	1708AS/20
1 raschietto a tre taglienti 200 mm	1717B
5 lime taglio mezzodolce 200 mm	1719BMA/S5
1 seghetto	1725

5904VG/4

Assortimento di 99 utensili

Autoriparazione



14,5 kg



5904VG/4	059040051
2400 O/VG4 (C24 O+5904VG/4)	024000233
2400 G/VG4 (C24 G+5904VG/4)	024000237
2400 R/VG4 (C24 R+5904VG/4)	024000239
2400W O/VG4 (CX24W O+5904VG/4)	024000431
2400W G/VG4 (CX24W G+5904VG/4)	024000432
2400W R/VG4 (CX24W R+5904VG/4)	024000433
2400H6 O/VG4 (C24H6 O+5904VG/4)	024000652
2400H6 G/VG4 (C24H6 G+5904VG/4)	024000653
2400H6 R/VG4 (C24H6 R+5904VG/4)	024000654
3600 O-5/VG4 (C36 O/5+5904VG/4)	036000121
3600 G-5/VG4 (C36 G/5+5904VG/4)	036000122
3600 R-5/VG4 (C36 R/5+5904VG/4)	036000123

N. pezzi/Descrizione

N. pezzi/Descrizione	Beta N.
2 scalpelli piatti nervati 100 - 200 mm	35
21 chiavi combinate 6+22 - 24 - 27 - 30 - 32 mm	42
8 chiavi a forchetta 6x7 - 8x9 - 10x11 - 12x13 - 14x15 - 16x17 - 18x19 - 20x22 mm	55
9 chiavi maschio esagonale piegate 1,5 - 2 - 2,5 - 3 - 4 - 5 - 6 - 8 - 10 mm	96/SP9
6 chiavi maschio esagonale con impugnatura 2 - 2,5 - 3 - 4 - 5 - 6 mm	96T
6 chiavi maschio con impugnatura per viti con impronta Torx® T10 - T15 - T20 - T25 - T27 - T30	97TTX
19 chiavi a bussola esagonali 1/2", 10+24 - 26 - 27 - 30 - 32 mm	920A
5 chiavi a bussola maschio esagonale 1/2", 5 - 6 - 8 - 10 - 12 mm	920ME
1 prolunga 125 mm - 1/2"	920/21
1 prolunga 255 mm - 1/2"	920/22
1 snodo 1/2"	920/25
1 quadro maschio 1/2" con spina scorrevole	920/42
1 cricchetto reversibile 1/2"	920/55
1 pinza becchi dritti per anelli elastici, per fori 180 mm	1032
1 pinza becchi piegati per anelli elastici, per fori 170 mm	1034
1 pinza becchi dritti per anelli elastici, per alberi 175 mm	1036
1 pinza becchi piegati per anelli elastici, per alberi 175 mm	1038
1 pinza regolabile cerniera chiusa 240 mm	1048
1 pinza regolabile autobloccante 240 mm	1052
1 tronchese a grande effetto taglienti diagonali 160 mm	1084
1 pinza universale 180 mm	1150
1 pinza a becchi mezzotondi dritti 160 mm	1166
4 giravite lama piatta 3x75 - 4x100 - 5,5x150 - 6,5x150 mm	1270
3 giravite Phillips® PH0x60 - PH1x80 - PH2x100 mm	1272
1 martello tipo tedesco 300 g	1370
1 mazzuola con battente in materiale plastico Ø 35 mm	1390

5904VG/5

Assortimento di 132 utensili

Autoriparazione



20,7 kg

5904VG/5	059040052
2400 O/VG5 (C24 O+5904VG/5)	024000253
2400 G/VG5 (C24 G+5904VG/5)	024000258
2400 R/VG5 (C24 R+5904VG/5)	024000259
2400CX O/VG5 (CX24 O+5904VG/5)	024000426
2400CX G/VG5 (CX24 G+5904VG/5)	024000427
2400CX R/VG5 (CX24 R+5904VG/5)	024000428
2400W O/VG5 (CX24W O+5904VG/5)	024000435
2400W G/VG5 (CX24W G+5904VG/5)	024000436
2400W R/VG5 (CX24W R+5904VG/5)	024000437
2400XL/VG5 (C24XL+5904VG/5)	024000155
3600 O-7/VG5 (C36 O/7+5904VG/5)	036000134
3600 G-7/VG5 (C36 G/7+5904VG/5)	036000135
3600 R-7/VG5 (C36 R/7+5904VG/5)	036000136

N. pezzi/Descrizione

N. pezzi/Descrizione	Beta N.
6 cacciapina Ø 2÷8 mm	31/B6
1 bulino Ø 5 mm	32
1 scalpello piatto nervato 200 mm	35
17 chiavi combinate 6÷22 mm	42
8 chiavi a forchetta 6x7 - 8x9 - 10x11 - 12x13 - 14x15 - 16x17 - 18x19 - 20x22 mm	55
9 chiavi maschio esagonale piegate 1,5 - 2 - 2,5 - 3 - 4 - 5 - 6 - 8 - 10 mm	96N/SP9
11 chiavi maschio esagonale con impugnatura 2÷10 mm	96T/SP11
13 chiavi maschio piegate per viti con impronta Torx® T6+T50	97TX/B13
1 chiave regolabile a rullino 300 mm	110
13 chiavi a bussola esagonali 1/2" con guida 10÷22 mm	920A/SB13
1 prolunga 125 mm - 1/2"	920/21
1 prolunga 255 mm - 1/2"	920/22
1 snodo 1/2"	920/25
1 quadro maschio 1/2" con spina scorrevole	920/42
1 cricchetto con quadro scorrevole 1/2"	920/50
6 chiavi a T con bussola snodata 8 - 10 - 12 - 13 - 17 - 19 mm	952
1 leva piatta curva con impugnatura 400 mm	965
2 pinze becchi dritti per anelli elastici, per fori 180 - 225 mm	1032
2 pinze becchi piegati per anelli elastici, per fori 170 - 210 mm	1034
2 pinze becchi dritti per anelli elastici, per alberi 175 - 225 mm	1036
2 pinze becchi piegati per anelli elastici, per alberi 175 - 220 mm	1038
1 pinza regolabile cerniera chiusa 240 mm	1048
1 pinza regolabile autobloccante 240 mm	1052
1 tronchese a grande effetto taglienti diagonali 200 mm	1084BM
1 tronchese doppia leva taglio frontale 200 mm	1092V
1 cesoia a lame larghe diritte 250 mm	1112
1 forbici per elettricisti lame diritte	1128BMX
1 pinza universale 180 mm	1150BM
4 giravite lama piatta 3x75 - 4x100 - 6,5x200 - 8x150 mm	1270
1 giravite nano lama piatta 6,5x30 mm	1270N
2 giravite lama piatta con esagono di manovra 6,5x150 - 10x175 mm	1270E
3 giravite Phillips® PH0x100 - PH1x120 - PH2x100 mm	1272
1 giravite nano Phillips® PH2x30 mm	1272N
1 giravite lama Phillips® con esagono di manovra PH3x175mm	1272E
1 giravite lungo Phillips® PH2x400 mm	1272L
1 giravite lungo a lama parallela 6,5x400 mm	1274L
1 martello tipo tedesco 500 g	1370
1 mazzuola con battente in materiale plastico Ø 45 mm	1390
1 chiave regolabile a nastro per filtri olio	1491
1 spessimetro a 20 lame	1708/20
5 lime taglio mezzodolce 200 mm	1719BMA/S5
1 seghetto	1726BM
1 oliatore in metallo a pressione 200 cc	1751

5904VG/6

Assortimento di 135 utensili

Autoriparazione

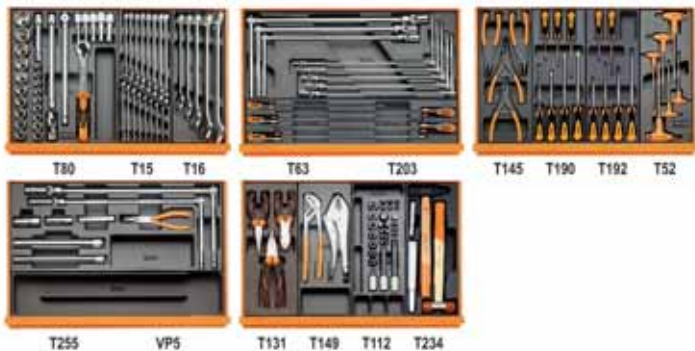

21,5 kg

	5904VG/6	059040053
	2400H O/VG6 (C24H O+5904VG/6)	024000576
	2400H G/VG6 (C24H G+5904VG/6)	024000578
	2400H R/VG6 (C24H R+5904VG/6)	024000579
	2800T O/VG6 (C28T O+5904VG/6)	028000295
	2800T G/VG6 (C28T G+5904VG/6)	028000297
	2800T R/VG6 (C28T R+5904VG/6)	028000299
	3600 O-7/VG6 (C36 O/7+5904VG/6)	036000184
	3600 G-7/VG6 (C36 G/7+5904VG/6)	036000185
	3600 R-7/VG6 (C36 R/7+5904VG/6)	036000186
	3900 O/VG6 (C39 O+5904VG/6)	039000081
	3900 G/VG6 (C39 G+5904VG/6)	039000082
	3900 R/VG6 (C39 R+5904VG/6)	039000083

N. pezzi/Descrizione

- 2 scalpelli piatti nervati 100 - 200 mm
- 21 chiavi combinate 6+22 - 24 - 27 - 30 - 32 mm
- 6 chiavi maschio esagonale con impugnatura 2 - 2,5 - 3 - 4 - 5 - 6 mm
- 6 inserti per avvitatori per viti con impronta Torx® T6+T15
- 8 inserti per avvitatori per viti con impronta Torx® T20+T55
- 1 bussola portainseri 1/4x1/4"
- 1 bussola portainseri 5/16x1/2"
- 6 chiavi a bussola 1/4" per viti con teste a profilo Torx® E4+E10
- 19 chiavi a bussola esagonali 1/2", 10+24 - 26 - 27 - 30 - 32 mm
- 7 chiavi a bussola 1/2" per viti con teste a profilo Torx® E12+E24
- 5 chiavi a bussola maschio esagonale 1/2", 5 - 6 - 8 - 10 - 12 mm
- 3 chiavi a bussola maschio per viti con impronta Torx® 1/2", T55L - T60 - T70L
- 1 prolunga 125 mm - 1/2"
- 1 prolunga 255 mm - 1/2"
- 1 snodo 1/2"
- 1 quadro maschio 1/2" con spina scorrevole
- 1 cricchetto reversibile 1/2"
- 8 chiavi a T con bussola snodata 7 - 8 - 10 - 12 - 13 - 14 - 17 - 19 mm
- 2 chiavi a bussola per candele □ 3/8", 16 - 20,8 mm
- 2 chiavi a bussola per candele □ 1/2", 16 - 20,8 mm
- 2 chiavi a T con bussola snodata per candele 16 - 20,8 mm
- 1 pinza becchi dritti per anelli elastici, per fori 180 mm
- 1 pinza becchi piegati per anelli elastici, per fori 170 mm
- 1 pinza becchi dritti per anelli elastici, per alberi 175 mm
- 1 pinza becchi piegati per anelli elastici, per alberi 175 mm
- 1 pinza regolabile cerniera chiusa 240 mm
- 1 pinza regolabile autobloccante 240 mm
- 1 tronchese a grande effetto taglienti diagonali 160 mm
- 1 pinza universale 180 mm
- 1 pinza a becchi mezzotondi dritti 160 mm
- 7 giravite lama piatta 2,5x50 - 3x75 - 3,5x100 - 4x125
5,5x100 - 5,5x150 - 6,5x150 mm
- 6 giravite Phillips® PH0x60 - PH0x100 - PH1x80 - PH1x120
PH2x100 - PH2x150 mm
- 2 giravite lunghi Phillips® PH1x400 - PH2x400 mm
- 3 giravite lunghi a lama parallela 3x300 - 4x400 - 5x400 mm
- 1 martello tipo tedesco 300 g
- 1 mazzuola con battente in materiale plastico Ø 35 mm
- 1 pinza per estrazione cappucci candele 200 mm
- 1 spessimetro a 20 lame
- 1 termoformato vuoto

Beta N.

- 35
- 42
- 96T
- 861TX
- 866TX
- 895/1
- 895/6
- 900FTX
- 920A
- 920FTX
- 920ME
- 920TX
- 920/21
- 920/22
- 920/25
- 920/42
- 920/55
- 952
- 956E
- 956L
- 959
- 1032
- 1034
- 1036
- 1038
- 1048
- 1052
- 1084BM
- 1150BM
- 1166BM
- 1270
- 1272
- 1272L
- 1274L
- 1370
- 1390
- 1474
- 1708/20
- VP5

5904VG/7

Assortimento di 82 utensili

Autoriparazione



N. pezzi/Descrizione

N. pezzi/Descrizione	Beta N.
2 scalpelli piatti nervati 100 - 200 mm	35
21 chiavi combinate 6+22 - 24 - 27 - 30 - 32 mm	42
8 chiavi maschio esagonale con impugnatura 2 - 2,5 - 3 - 4 - 5 - 6 - 7 - 8 mm	96T
19 chiavi a bussola esagonali 1/2", 10+24 - 26 - 27 - 30 - 32 mm	920A
5 chiavi a bussola maschio esagonale 1/2", 5 - 6 - 8 - 10 - 12 mm	920ME
1 prolunga angolare 125 mm - 1/2"	920AN/125
1 prolunga angolare 250 mm - 1/2"	920AN/250
1 snodo 1/2"	920/25
1 quadro maschio 1/2" con spina scorrevole	920/42
1 cricchetto reversibile 1/2"	920/55
1 pinza becchi dritti per anelli elastici, per fori 180 mm	1032
1 pinza becchi piegati per anelli elastici, per fori 170 mm	1034
1 pinza becchi dritti per anelli elastici, per alberi 175 mm	1036
1 pinza becchi piegati per anelli elastici, per alberi 175 mm	1038
1 tronchese a grande effetto taglienti diagonali 160 mm	1084BM
1 pinza universale 180 mm	1150BM
1 pinza a becchi mezzotondi dritti 160 mm	1166BM
7 giravite lama piatta 2,5x50 - 3x75 - 3,5x100 - 4x125 5,5x100 - 5,5x150 - 6,5x150 mm	1290
6 giravite Phillips® PH0x60 - PH0x100 - PH1x80 PH1x120 - PH2x100 - PH2x150 mm	1292
1 martello tipo tedesco 300 g	1370
1 mazzuola con battente in materiale plastico Ø 35 mm	1390

13,2 kg

5904VG/7	059040054
----------	-----------



2400H6 O/VG7 (C24H6 O+5904VG/7)	024000682
------------------------------------	-----------



2400H6 G/VG7 (C24H6 G+5904VG/7)	024000683
------------------------------------	-----------



2400H6 R/VG7 (C24H6 R+5904VG/7)	024000684
------------------------------------	-----------



3600 O-5/VG7 (C36 O/5+5904VG/7)	036000191
------------------------------------	-----------



3600 G-5/VG7 (C36 G/5+5904VG/7)	036000192
------------------------------------	-----------



3600 R-5/VG7 (C36 R/5+5904VG/7)	036000193
------------------------------------	-----------



3600 O-7/VG7 (C36 O/7+5904VG/7)	036000194
------------------------------------	-----------



3600 G-7/VG7 (C36 G/7+5904VG/7)	036000195
------------------------------------	-----------



3600 R-7/VG7 (C36 R/7+5904VG/7)	036000196
------------------------------------	-----------



3900 O/VG7 (C39 O+5904VG/7)	039000091
--------------------------------	-----------



3900 G/VG7 (C39 G+5904VG/7)	039000092
--------------------------------	-----------



3900 R/VG7 (C39 R+5904VG/7)	039000093
--------------------------------	-----------

5905VG/0

Assortimento di 90 utensili

Autoriparazione



14 kg

5905VG/0

059050061



2500/VG0
(C25+5905VG/0)

025000071

N. pezzi/Descrizione

4	cacciaspina Ø 2 - 3 - 4 - 5 mm	31
1	bulino Ø 4 mm	32
1	scalpello 150 mm	34
12	chiavi combinate 6 - 7 - 8 - 10 - 11 - 12 - 13 - 14 - 17 - 19 - 22 - 24 mm	42
9	chiavi maschio esagonale piegate con estremità sferica, 1,5 - 2 - 2,5 - 3 - 4 - 5 - 6 - 8 - 10 mm	96BPC/SP9
5	chiavi maschio esagonale piegate con impugnatura 3 - 4 - 5 - 6 - 8 mm	96T/S5
20	chiavi a bussola esagonali 1/2", 10+24 - 26 - 27 - 28 - 30 - 32 mm	920A
1	prolunga 125 mm - 1/2"	920/21
1	prolunga 255 mm - 1/2"	920/22
1	snodo 1/2"	920/25
1	quadro maschio 1/2" con spina scorrevole	920/42
1	cricchetto reversibile 1/2"	920/55
8	chiavi a T con bussola snodata, 8 - 10 - 12 - 13 - 14 - 15 - 16 - 17 mm	952
1	chiavi a bussola per candele, 16 mm	956C
1	pinza becchi dritti per anelli elastici, per fori 180 mm	1032
1	pinza becchi dritti per anelli elastici, per alberi 175 mm	1036
1	pinza regolabile cerniera chiusa 240 mm	1048
1	tronchese a grande effetto taglienti diagonali 160 mm	1084BM
1	pinza universale 180 mm	1150BM
1	pinza a becchi mezzotondi dritti 160 mm	1166BM
1	forbici per elettricisti, lame diritte	1128BMX
1	giravite Dzus®	1201DZ
5	giravite lama piatta 3x75 - 4x100 - 5,5x150 - 6,5x150 - 8x150 mm	1290/S5
4	giravite Phillips® PH0x60 - PH1x80 - PH2x100 - PH3x150 mm	1292/S4
4	chiavi maschio con impugnatura per viti con impronta Torx® T15 - T20 - T30 - T40	1297TX
1	martello tipo tedesco 400 g	1370
1	mazzuola con battente in materiale plastico Ø 35 mm	1390
1	chiave a nastro per filtri olio	1490/1

Beta N.

5905VG/4

Assortimento di 117 utensili

Autoriparazione



19,5 kg

5905VG/4

059050033



2500/VG4
(C25+5905VG/4)

025000048

N. pezzi/Descrizione

2	punzoni Ø 3 - 4 mm	30
4	cacciaspina Ø 2 - 3 - 4 - 5 mm	31
1	bulino Ø 4 mm	32
2	scalpelli piatti normali 125 - 150 mm	34
2	ugnetti normali 125 - 150 mm	36
14	chiavi combinate 5,5+14 - 17 - 19 - 22 - 24 mm	42
13	chiavi a forchetta 6x7 - 8x9 - 10x11 - 12x13 - 14x15 - 16x17 - 18x19 - 20x22 - 21x23 - 24x26 - 25x28 - 27x29 - 30x32 mm	55
3	chiavi poligonali doppie starter 11x13 - 14x17 - 19x22 mm	83
10	chiavi maschio esagonale piegate 1,5+12 mm	96N/B10
2	chiavi a bussola Macchina 1/2", 17 - 19 mm	720
20	chiavi a bussola esagonali 1/2", 10+24 - 26 - 27 - 28 - 30 - 32 mm	920A
1	prolunga 125 mm - 1/2"	920/21
1	prolunga 255 mm - 1/2"	920/22
1	snodo 1/2"	920/25
1	quadro maschio 1/2" con spina scorrevole	920/42
1	cricchetto reversibile 1/2"	920/55
8	chiavi a T con bussola snodata 7 - 8 - 10 - 11 - 13 - 14 - 17 - 19 mm	952
1	chiave a T con bussola snodata per candele 20,8 mm	959
1	chiave a croce 17x19x22x 1/2"	979
1	pinza becchi dritti per anelli elastici, per fori 180 mm	1032
1	pinza becchi piegati per anelli elastici, per fori 170 mm	1034
1	pinza becchi dritti per anelli elastici, per alberi 175 mm	1036
1	pinza becchi piegati per anelli elastici, per alberi 175 mm	1038
1	pinza regolabile cerniera chiusa 240 mm	1048
1	pinza regolabile autobloccante 240 mm	1052
1	tronchese a grande effetto taglienti diagonali 160 mm	1084BM
1	cesoia a lame larghe diritte 250 mm	1112
1	forbici per elettricisti lame diritte	1128BMX
1	pinza universale 180 mm	1150BM
1	pinza a becchi mezzotondi dritti 160 mm	1166BM
7	giravite lama piatta 2,5x50 - 3x75 - 3,5x100 - 4x125 - 5,5x150 - 6,5x150 - 10x200 mm	1270
2	giravite lama piatta con esagono di manovra 10x175 - 12x200 mm	1270E
1	giravite nano lama piatta 6,5x30 mm	1270N
4	giravite Phillips® PH0x60 - PH1x80 - PH2x100 - PH3x150 mm	1272
1	martello tipo tedesco 400 g	1370
1	mazzuola con battenti in materiale plastico Ø 35 mm	1390
1	chiave regolabile a nastro per filtri olio	1491
1	provatensione 3+48 V	1498

Beta N.

5905VCR/1

Assortimento di 93 utensili per carrozzieri

Autoriparazione



20 kg

5905VCR/1 059050047



2500/VCR1
(C25+5905VCR/1) 025000047

N. pezzi/Descrizione

N. pezzi/Descrizione	Beta N.
1 punzone Ø 4 mm	30
6 cacciapina Ø 2 - 3 - 4 - 5 - 6 - 8 mm	31/B6
1 bulino Ø 4 mm	32
1 scalpello piatto normale 150 mm	34
1 ugnetto normale 150 mm	36
17 chiavi combinate 6+22 mm	42/S17
10 chiavi maschio esagonale piegate 1,5+12 mm	96/B10
1 chiave regolabile a rullino 300 mm	112N
12 chiavi a bussola con impugnatura, tipo lungo 4+14 mm	943BM
1 leva piatta curva con impugnatura 400 mm	965
1 pinza regolabile cerniera chiusa 240 mm	1048
1 pinza regolabile autobloccante 240 mm	1052
1 pinza autobloccante ganasce alluminio 280 mm	1060AL
1 tronchese a grande effetto taglienti diagonali 160 mm	1084BM
1 tenaglia per cementisti 250 mm	1098PL
1 cesoia a doppia leva dritta	1122
1 forbici per elettricisti, lame diritte	1128BMX
1 pinza universale 180 mm	1150BM
1 giravite per viti con impronta Dzus®	1201DZ
4 giravite lama piatta 3x75 - 4x100 - 5,5x150 - 6,5x150 mm	1270
1 giravite nano lama piatta 4x30 mm	1270N
2 giravite lama piatta con esagono di manovra 10x175 - 12x200 mm	1270E
3 giravite Phillips® PH0x60 - PH1x80 - PH2x100 mm	1272
1 giravite nano Phillips® PH1x30 mm	1272N
1 giravite lama Phillips® con esagono di manovra PH3x175 mm	1272E
6 chiavi maschio per viti con impronta Torx® T10 - T15 - T20 - T25 - T27 - T30	1277TX
1 tasso a virgola 1350 g	1303
1 tasso curvo	1305
1 tasso a tacco bombato	1306
1 tasso a rotaia	1310
1 tasso a tampone	1313
1 leva a cazzuola	1326
1 leva a cucchiaio pesante	1327
1 leva a gomito e piana	1330
1 lima e portailima	1338A
1 scalpello extrapiatto con paramano	1342PM
1 martello con testa tonda e penna	1345
1 martello con testa tonda e quadra Ø 32 mm	1357Z/32
1 martello tipo tedesco 300 g	1370
1 mazzuola con battente in materiale plastico Ø 35 mm	1390
1 flessometro 5 m	1691A/5

5908VG/4

Assortimento di 171 utensili

Autoriparazione



30 kg

5908VG/4 059080042



2800N O/VG4
(C28N O+5908VG/4) 028000257



2800N G/VG4
(C28N G+5908VG/4) 028000267



2800N R/VG4
(C28N R+5908VG/4) 028000270

N. pezzi/Descrizione

N. pezzi/Descrizione	Beta N.
6 cacciapina Ø 2 - 3 - 4 - 5 - 6 - 8 mm	31/B6
1 bulino Ø 5 mm	32
1 scalpello piatto nervato 200 mm	35
21 chiavi combinate 6+22 - 24 - 27 - 30 - 32 mm	42
13 chiavi a forchetta 6x7 - 8x9 - 10x11 - 12x13 - 14x15 - 16x17 - 18x19 - 20x22 - 21x23 - 24x26 - 25x28 - 27x29 - 30x32 mm	55
8 chiavi poligonali curve 6x7 - 8x9 - 10x11 - 12x13 - 14x15 - 16x17 - 18x19 - 20x22 mm	90/S8
15 chiavi maschio esagonale piegate 1,5 - 2 - 2,5 - 3 - 4 - 5 - 6 - 7 - 8 - 10 - 12 - 13 - 14 - 17 - 19 mm	96N
11 chiavi maschio esagonale con impugnatura 2+10 mm	96T/SP11
11 chiavi maschio con impugnatura per viti con impronta Torx® T8+T50	97TTX/S11
1 chiave regolabile a rullino 300 mm	110
13 chiavi a bussola esagonali 1/2" con guida 10+22 mm	920A/SB13
8 chiavi a bussola esagonali 1/2" con guida 23+32 mm	920A/SB8
7 chiavi a bussola maschio esagonale 1/2", 5 - 6 - 8 - 10 - 12 - 14 - 17 mm	920ME
1 prolunga 125 mm - 1/2"	920/21
1 prolunga 255 mm - 1/2"	920/22
1 snodo 1/2"	920/25
1 quadro maschio 1/2" con spina scorrevole	920/42
1 cricchetto con quadro scorrevole 1/2"	920/55
6 chiavi a T con bussola snodata 8 - 10 - 12 - 13 - 17 - 19 mm	952
1 leva piatta curva con impugnatura 400 mm	965
2 pinze becchi dritti per anelli elastici, per fori 180 - 225 mm	1032
2 pinze becchi piegati per anelli elastici, per fori 170 - 210 mm	1034
2 pinze becchi dritti per anelli elastici, per alberi 175 - 225 mm	1036
2 pinze becchi piegati per anelli elastici, per alberi 175 - 220 mm	1038
1 pinza regolabile cerniera chiusa 240 mm	1048
1 pinza regolabile autobloccante 240 mm	1052
1 tronchese a grande effetto taglienti diagonali 200 mm	1084BM
1 tronchese doppia leva taglio frontale 200 mm	1092V
1 cesoia a lame larghe diritte 250 mm	1112
1 forbici per elettricisti lame diritte	1128BMX
1 pinza universale 180 mm	1150BM
4 giravite lama piatta 3x75 - 4x100 - 6,5x200 - 8x150 mm	1270
1 giravite nano lama piatta 6,5x30 mm	1270N
3 giravite lama piatta con esagono di manovra 6,5x150 - 10x175 - 12x200 mm	1270E
2 giravite Phillips® PH0x100 - PH1x120 mm	1272
1 giravite nano Phillips® PH2x30 mm	1272N
2 giravite Phillips® con esagono di manovra PH3x175 - PH4x200 mm	1272E
1 giravite lungo Phillips® PH2x400 mm	1272L
1 giravite lungo lama parallela 6,5x400 mm	1274L
2 martelli tipo tedesco 300 - 1000 g	1370
1 mazzuola con battente in materiale plastico Ø 60 mm	1390
1 chiave regolabile a nastro per filtri olio	1491
1 spessimetro a 20 lame	1708/20
1 flessibile magnetico 0,5 kg	1712E/1
5 lime taglio mezzadolce 200 mm	1719BMA/S5
1 seghetto	1726BM
1 oliatore in metallo a pressione 200 cc	1751

5908VG/5

Assortimento di 208 utensili

Autoriparazione



58,1 kg

5908VG/5 059080053



2800N O/VG5 028000258
(C28N O+5908VG/5)



2800N G/VG5 028000268
(C28N G+5908VG/5)



2800N R/VG5 028000278
(C28N R+5908VG/5)

N. pezzi/Descrizione

Beta N.

6	cacciaspina Ø 2 - 3 - 4 - 5 - 6 - 8 mm	31
1	bulino Ø 5 mm	32
2	scalpelli piatti nervati 100 - 200 mm	35
25	chiavi combinate 6+22 - 24 - 27 - 30 - 32 - 35 - 36 - 38 - 41 mm	42
13	chiavi a forchetta 6x7 - 8x9 - 10x11 - 12x13 - 14x15 - 16x17 18x19 - 20x22 - 21x23 - 24x26 - 25x28 - 27x29 - 30x32 mm	55
15	chiavi poligonali curve 6x7 - 8x9 - 10x11 - 12x13 - 14x15 - 16x17 18x19 - 20x22 - 21x23 - 24x26 - 25x28 - 27x29 - 30x32 - 35x38 - 36x41 mm	90
1	chiave per raccordi tubi 17x19 mm	94
4	chiavi maschio esagonale piegate 13 - 14 - 17 - 19 mm	96N
10	chiavi maschio esagonale piegate 1,5+12 mm	96N/B10
13	chiavi maschio piegate per viti con impronta Torx® T6+T50	97TX/B13
1	chiave regolabile a rullino 300 mm	110
7	chiavi a bussola Macchina lunghe sottili 3/4", 22 - 24 - 27 - 30 - 32 - 33 - 36 mm	728LS
13	chiavi a bussola esagonali 1/2" con guida 10+22 mm	920A/SB13
8	chiavi a bussola esagonali 1/2" con guida 23+32 mm	920A/SB8
7	chiavi a bussola maschio esagonale 1/2", 5-17 mm	920ME/SB7
1	raccordo quadro maschio 3/4" e femmina 1/2"	920/16
1	prolunga 125 mm - 1/2"	920/21
1	prolunga 255 mm - 1/2"	920/22
1	snodo 1/2"	920/25
1	quadro maschio 1/2" con spina scorrevole	920/42
1	cricchetto con quadro scorrevole 1/2"	920/50
11	chiavi a bussola esagonali 3/4", 22 - 24 - 27 - 30 - 32 - 36 - 41 - 46 - 50 - 55 - 60 mm	928A
1	prolunga 200 mm - 3/4"	928/21
1	prolunga 380 mm - 3/4"	928/22
1	quadro maschio 3/4" con spina scorrevole	928/42
1	cricchetto reversibile 3/4"	928/55
7	chiavi a T con bussola snodata 8 - 10 - 12 - 13 - 14 - 17 - 19 mm	952
1	leva piatta curva con impugnatura 600 mm	965
3	pinze becchi dritti per anelli elastici, per fori 180 - 225 - 300 mm	1032
3	pinze becchi piegati per anelli elastici, per fori 170 - 210 - 290 mm	1034
3	pinze becchi dritti per anelli elastici, per alberi 175 - 225 - 300 mm	1036
3	pinze becchi piegati per anelli elastici, per alberi 175 - 220 - 300 mm	1038
2	pinze regolabili cerniera chiusa 240 - 300 mm	1048
1	pinza autobloccante a doppia regolazione 255 mm	1051
1	tronchese a grande effetto taglienti diagonali 200 mm	1084BM
1	tronchese doppia leva taglio frontale 200 mm	1092V
1	cesoia a lame larghe diritte 250 mm	1112
1	forbici per elettricisti lame diritte	1128BMX
1	pinza universale 180 mm	1150BM
3	giravite lama piatta 3x75 - 4x100 - 8x200 mm	1270
1	giravite nano lama piatta 6,5x30	1270N
4	giravite lama piatta con esagono di manovra 5,5x125 - 6,5x150 - 10x175 - 12x200 mm	1270E
2	giravite Phillips® PH0x100 - PH1x120 mm	1272
1	giravite nano Phillips® PH2x30 mm	1272N
3	giravite Phillips® con esagono di manovra PH2x150 - PH3x175 - PH4x200 mm	1272E
1	giravite lungo Phillips® PH2x400 mm	1272L
1	giravite lungo lama parallela 6,5x400 mm	1274L
2	martelli tipo tedesco 500 - 2000 g	1370
1	mazzuola antirimbalo Ø 50 mm	1392
1	chiave regolabile a nastro per filtri olio	1491
1	spessimetro a 20 lame	1708/20
1	flessibile magnetico 1,8 kg	1712E/2
1	specchietto telescopico snodato	1715
1	raschietto a tre taglienti 200 mm	1717B
5	lime taglio mezzodolce 200 mm	1719BMA/S5
1	seghetto	1726BM
1	spazzola fili d'acciaio	1737NX
1	oliatore in metallo a pressione 200 cc	1751
1	cutter con lama a settori	1771BM

5909VG/2

Assortimento di 160 utensili

Autoriparazione



25 kg

	2400 H O/VG2 (C24H O+5909VG/2)	024000586
	2400 H G/VG2 (C24H G+5909VG/2)	024000588
	2400 H R/VG2 (C24H R+5909VG/2)	024000589
	3600 O-7/VG2 (C36 O/7+5909VG/2)	036000174
	3600 G-7/VG2 (C36 G/7+5909VG/2)	036000175
	3600 R-7/VG2 (C36 R/7+5909VG/2)	036000176
	3900 O/VG2 (C39 O+5909VG/2)	039000071
	3900 G/VG2 (C39 G+5909VG/2)	039000072
	3900 R/VG2 (C39 R+5909VG/2)	039000073

N. pezzi/Descrizione

N. pezzi/Descrizione	Beta N.
2 scalpelli piatti nervati 100 - 200 mm	35
21 chiavi combinate 6x22 - 24 - 27 - 30 - 32 mm	42
8 chiavi a forchetta 6x7 - 8x9 - 10x11 - 12x13 - 14x15 - 16x17 - 18x19 - 20x22	55
9 chiavi maschio esagonali piegate 1,5 - 2 - 2,5 - 3 - 4 - 5 - 6 - 8 - 10 mm	96/SP9
6 chiavi maschio esagonale con impugnatura 2 - 2,5 - 3 - 4 - 5 - 6 mm	96T
6 inserti per avvitatori per viti con impronta Torx® T6+T15	861TX
8 inserti per avvitatori per viti con impronta Torx® T20+T55	866TX
1 bussola portainseri 1/4x1/4"	895/1
1 bussola portainseri 5/16x1/2"	895/6
6 chiavi a bussola 1/4" per viti con teste a profilo Torx® E4+E10	900FTX
19 chiavi a bussola esagonali 1/2", 10+24 - 26 - 27 - 30 - 32 mm	920A
7 chiavi a bussola 1/2" per viti con teste a profilo Torx® E12+E24	920FTX
5 chiavi a bussola maschio esagonale 1/2", 5 - 6 - 8 - 10 - 12 mm	920ME
3 chiavi a bussola maschio per viti con impronta Torx® 1/2", T55L - T60 - T70L	920TX
1 prolunga 125 mm - 1/2"	920/21
1 prolunga 255 mm - 1/2"	920/22
1 snodo 1/2"	920/25
1 quadro maschio 1/2" con spina scorrevole	920/42
1 cricchetto reversibile 1/2"	920/55
8 chiavi a T con bussola snodata 7 - 8 - 10 - 12 - 13 - 14 - 17 - 19 mm	952
1 pinza becchi dritti per anelli elastici, per fori 180 mm	1032
1 pinza becchi piegati per anelli elastici, per fori 170 mm	1034
1 pinza becchi dritti per anelli elastici, per alberi 175 mm	1036
1 pinza becchi piegati per anelli elastici, per alberi 175 mm	1038
1 pinza regolabile cerniera chiusa 240 mm	1048
1 pinza regolabile autobloccante 240 mm	1052
1 tronchese a grande effetto taglienti diagonali 160 mm	1084BM
1 pinza universale 180 mm	1150BM
1 pinza a becchi mezzotondi dritti 160 mm	1166BM
10 giravite lama piatta 2,5x50 - 3x75 - 3,5x100 - 4x125 5,5x100 - 5,5x150 - 6,5x150 - 8x150 - 8x200 - 10x200 mm	1290
2 giravite nani lama piatta 4x30 - 6,5x30 mm	1290N
8 giravite Phillips® PH0x60 - PH0x100 - PH1x80 PH1x120 - PH2x100 - PH2x150 - PH3x150 - PH4x200 mm	1292
2 giravite nani Phillips® PH1x30 - PH2x30 mm	1292N
12 chiave maschio con impugnatura per viti con impronta Torx® T25 - T27 - T30 - T40 - T45	1297TX
1 martello tipo tedesco 300 g	1370S
1 mazzuola con battente in materiale plastico Ø 35 mm	1390
1 termoformato vuoto	VP6

5910VG/1

Assortimento di 316 utensili

Autoriparazione



79 kg

5910VG/1

059100036



3000/VG1
(C30+5910VG/1)

030000044

N. pezzi/Descrizione

Beta N.

6	cacciaspina Ø 2 - 3 - 4 - 5 - 6 - 8 mm	31
1	bulino Ø 5 mm	32
2	scalpelli piatti nervati 100 - 200 mm	35
8	chiavi combinate 24 - 27 - 30 - 32 - 35 - 36 - 38 - 41 mm	42
17	chiavi combinate 6+22 mm	42/S17
13	chiavi a forchetta 6x7 - 8x9 - 10x11 - 12x13 - 14x15 - 16x17 18x19 - 20x22 - 21x23 - 24x26 - 25x28 - 27x29 - 30x32 mm	55/S13
5	chiavi poligonali doppie starter 8x10 - 10x12 - 11x13 - 14x17 - 19x22 mm	83
2	chiavi poligonali curve 35x38 - 36x41 mm	90
13	chiavi poligonali curve 6x7+30x32 mm	90/S13
1	chiave per raccordi tubi 17x19 mm	94
4	chiavi maschio esagonale piegate 13 - 14 - 17 - 19 mm	96N
10	chiavi maschio esagonale piegate 1,5 - 2 - 2,5 - 3 - 4 - 5 - 6 - 8 - 10 - 12 mm	96N/B10
11	chiavi maschio esagonale con impugnatura 2+10 mm	96T/SP11
13	chiavi maschio piegate per viti con impronta Torx® T6+T50	97TX/S13
1	chiave regolabile a rullino 300 mm	110
1	chiave dinamometrica a scatto 1/2" 40+200 Nm	606/20
7	chiavi a bussola Macchina lunghe sottili 3/4", 22+36 mm	728/S
30	assortimento di 13 chiavi a bussola, 11 giravite e 6 accessori 1/2"	900/C24
13	chiavi a bussola esagonali 1/2" con guida 10+22 mm	920A/SB13
8	chiavi a bussola esagonali 1/2" con guida 23+32 mm	920A/SB8
6	chiavi a bussola 1/2" per viti con testa a profilo Torx® con guida E10+E20	920FTX/SB6
7	chiavi a bussola maschio esagonale 1/2", 5+17 mm	920ME/SB7
9	chiavi a bussola maschio per viti con impronta Torx® □ 1/2" con guida T20+T60	920TX/SB9
1	raccordo quadro maschio 3/4" e femmina 1/2"	920/16
1	prolunga 125 mm - 1/2"	920/21
1	prolunga 255 mm - 1/2"	920/22
1	snodo 1/2"	920/25
1	quadro maschio 1/2" con spina scorrevole	920/42
1	cricchetto con quadro scorrevole 1/2"	920/50
11	chiavi a bussola esagonali 3/4", 22 - 24 - 27 - 30 - 32 - 36 - 41 - 46 - 50 - 55 - 60 mm	928A
1	prolunga 200 mm - 3/4"	928/21
1	prolunga 380 mm - 3/4"	928/22
1	quadro maschio 3/4" con spina scorrevole	928/42
1	cricchetto reversibile 3/4"	928/55
12	chiavi a bussola con impugnatura, tipo lungo 4+14 mm	943BM/S12
7	chiavi a T con bussola snodata 8 - 10 - 12 - 13 - 14 - 17 - 19 mm	952
2	chiavi a T con bussola snodata per candele 16 - 20,8 mm	959
1	chiave per sonda Lambda 22xL 85 mm	960SL
1	leva con estremità a punta e piatta curva	963
3	leve piatte curve con impugnatura 300 - 400 - 600 mm	965
1	chiave a croce 17x19x22x 1/2"	979
3	pinze becchi dritti per anelli elastici, per fori 180 - 225 - 300 mm	1032
3	pinze becchi piegati per anelli elastici, per fori 170 - 210 - 290 mm	1034
3	pinze becchi dritti per anelli elastici, per alberi 175 - 225 - 300 mm	1036
3	pinze becchi piegati per anelli elastici, per alberi 175 - 220 - 300 mm	1038
2	pinze regolabili cerniera chiusa 240 - 300 mm	1048
1	pinza autobloccante a doppia regolazione	1051
1	pinza regolabile autobloccante 240 mm	1052
1	tronchese a grande effetto taglienti diagonali 200 mm	1084BM
1	tronchese doppia leva taglio frontale 200 mm	1092V
1	cesoia a lame larghe diritte 250 mm	1112
1	forbici per elettricisti lame diritte	1128BMX
1	pinza universale 180 mm	1150BM
3	giravite lama piatta 3x75 - 4x100 - 8x200 mm	1270
1	giravite nano lama piatta 6,5x30 mm	1270N
4	giravite lama piatta con esagono di manovra 5,5x125 - 6,5x150 - 10x175 - 12x200 mm	1270E
2	giravite Phillips® PH0x100 - PH1x120 mm	1272
1	giravite nano Phillips® PH2x30 mm	1272N
3	giravite lama Phillips® con esagono di manovra PH2x150 - PH3x175 - PH4x200 mm	1272E
1	giravite lungo lama Phillips® PH2x400 mm	1272L
1	giravite lungo lama parallela 6,5x400 mm	1274L
12	chiavi maschio per viti con impronta Torx® T6+T45	1277TX/S12
6	chiavi maschio per viti con impronta Tamper Resistant Torx® T10+T30	1278RTX/S6
2	martelli tipo tedesco 500 - 2000 g	1370
1	mazzuola antirimbalo Ø 50 mm	1392
1	pinza taglio tubi scappamento	1476A
1	chiave regolabile a nastro per filtri olio	1491
1	provatensione 3+48V	1498
1	pinza per capicorda non isolati chiusi	1603A
1	calibro a corsoio ventesimale	1650
1	spessimetro a 20 lame	1708/20
1	flessibile magnetico 1,8 kg	1712E/2
1	specchietto telescopico snodato	1715
1	raschietto a tre taglienti 200 mm	1717B
5	lime taglio mezzodolce 200 mm	1719BMA/S5
1	seghetto	1726BM
1	spazzola fili d'acciaio	1737NX
1	rivettatrice con assortimento di 700 rivetti	1741/C5
1	oliatore in metallo a pressione 200 cc	1751
1	cutter con lama a settori	1771BM
1	saldatore a doppia potenza 20-40 W	1816A
1	occhiali di protezione	1918
1	cuffia antirumore	1918C

5940M1

Assortimento di 138 utensili per motoriparazione

Motoriparazione



16 kg

5940M1 059400041



4100S/M1 (C41S+5940/M1) 041000031

4100H/M1 (C41H+5940/M1) 041000041

N. pezzi/Descrizione

N. pezzi/Descrizione	Beta N.
2 punzoni Ø 2 - 3 mm	30
1 bulino Ø 4 mm	32
2 scalpelli piatti 125 - 150 mm	34
1 ugnetto 150 mm	36
9 chiavi combinate 6 - 7 - 8 - 10 - 11 - 13 - 14 - 17 - 19 mm	42/B9
1 chiave combinata 12 mm	42
6 chiavi a forchetta 6x7 - 8x9 - 10x11 - 12x13 - 14x15 - 16x17 mm	55/B6
9 chiavi maschio esagonale piegate 1,5 - 2 - 2,5 - 3 - 4 - 5 - 6 - 8 - 10 mm	96/SP9
1 chiave dinamometrica a scatto 3/8" 8=60 Nm	606/6
54 assortimento di 52 inserti con attacco esagonale 10 mm e 2 accessori	867/C52
17 assortimento di 12 chiavi a bussola e 5 accessori	920A/C12X
1 snodo 3/8"	910/25
3 chiavi a T con bussola snodata 8 - 10 - 12 mm	952
2 chiavi a bussola per candele 3/8" 16 - 17,8 mm	956E
1 pinza a becchi mezzotondi lunghissimi 283 mm	1009L/A
2 pinze becchi dritti per anelli elastici, per fori 140 - 180 mm	1032
1 pinza becchi dritti per anelli elastici, per alberi 140x1,3 mm	1036
1 pinza autobloccante 235 mm	1054
1 tronchese a grande effetto taglienti diagonali 160 mm	1084
1 pinza universale 180 mm	1150
1 giravite per viti con impronta Dzus®	1201DZ
4 giravite lama piatta 3x75 - 4x100 - 5,5x100 - 6,5x150 mm	1201
3 giravite Phillips® PH0x60 - PH1x80 - PH2x100 mm	1202
1 giravite provacircuito	1262
1 martello tipo tedesco 500 g	1370
1 pinza per fascette a scatto Clic®	1472FS
2 pinze in plastica per occlusione tubi	1481PL/A-B
1 chiave regolabile a nastro metallico per filtri olio	1491
1 spessimetro a 13 lame	1708/13
3 lime ad ago	1720/S3
1 miniseghetto	1725SR
1 spazzola fili d'ottone	1737
1 oliatore in plastica a pressione 250 cc	1754
1 cutter	1770A

5953VG/2

Assortimento di 147 utensili

Autoriparazione



24,6 kg

5953VG/2 059530060



5300/VG2 (C53VG+5953VG/2) 053000041

N. pezzi/Descrizione

N. pezzi/Descrizione	Beta N.
5 cacciaspina Ø 2 - 3 - 4 - 5 - 6 mm	31
1 bulino Ø 4 mm	32
1 scalpello piatto normale 150 mm	34
18 chiavi combinate 6+14 - 16 - 17 - 18 - 19 - 21 - 22 - 24 - 27 - 30 mm	42
12 chiavi a forchetta 6x7 - 8x9 - 10x11 - 12x13 - 14x15 - 16x17	55
18x19 - 20x22 - 21x23 - 24x26 - 27x29 - 30x32 mm	
3 chiavi poligonali doppie starter 11x13 - 14x17 - 19x22 mm	83
12 chiavi maschio esagonale piegate 2+10 mm	96
11 chiavi maschio esagonale con impugnatura 2+8 - 10 mm	96T
20 chiavi a bussola esagonali 1/2", 10+24 - 26 - 27 - 28 - 30 - 32 mm	920A
5 chiavi a bussola maschio esagonale 1/2", 5 - 6 - 8 - 10 - 12 mm	920ME
1 prolunga 125 mm - 1/2"	920/21
1 prolunga 255 mm - 1/2"	920/22
1 snodo 1/2"	920/25
1 quadro maschio 1/2" con spina scorrevole	920/42
1 cricchetto reversibile 1/2"	920/55
10 chiavi a T con bussola snodata	952
6 - 7 - 8 - 10 - 11 - 12 - 13 - 14 - 17 - 19 mm	
2 chiavi a T con bussola snodata per candele 16 - 20,8 mm	959
1 chiave a croce 17x19x22x 1/2"	979
2 pinze becchi dritti per anelli elastici, per fori 140 - 180 mm	1032
1 pinza becchi piegati per anelli elastici, per fori 170 mm	1034
2 pinze becchi dritti per anelli elastici, per alberi 140x1,3 - 175 mm	1036
1 pinza becchi piegati per anelli elastici, per alberi 175 mm	1038
1 pinza regolabile carriera chiusa 240 mm	1048
1 pinza regolabile autobloccante 240 mm	1052
1 tronchese a grande effetto taglienti diagonali 160 mm	1084BM
1 cesoia a lame larghe diritte 250 mm	1112
1 forbici per elettricisti lame diritte	1128BMX
1 pinza universale 180 mm	1150BM
5 giravite lama piatta 3x75 - 4x100 - 5,5x100	1270
6,5x150 - 10x200 mm	
2 giravite nani lama piatta 4x30 - 6,5x30 mm	1270N
4 giravite Phillips® PH0x60 - PH1x80	1272
PH2x100 - PH3x150 mm	
2 giravite nani Phillips® PH1x30 - PH2x30 mm	1272N
1 giravite lungo lama Phillips® PH2x400 mm	1272L
1 giravite lungo lama parallela 6,5x400 mm	1274L
1 martello tipo tedesco 400 g	1370
1 mazzuola con battente in materiale plastico Ø 35 mm	1390
1 pinza per anelli elastici SP	1458
1 chiave regolabile a nastro per filtri olio	1491
1 pinza per capicorda non isolati	1603
1 spessimetro a 13 lame	1708/13
1 flessibile magnetico 0,5 kg	1712E/1
5 lime taglio mezzodolce 200 mm	1719BMA/S5
1 seghetto	1726BM
1 oliatore in plastica a pressione 250 cc	1754

5954VG/2

Assortimento di 138 utensili

Autoriparazione



18,9 kg

5954VG/2 059540060



5400 O/VG2 054000080
(C54VG O+5954VG/2)



5400 G/VG2 054000082
(C54VG G+5954VG/2)



5400 R/VG2 054000084
(C54VG R+5954VG/2)

N. pezzi/Descrizione

Beta N.

5	cacciaspina Ø 2 - 3 - 4 - 5 - 6 mm	31
1	bulino Ø 4 mm	32
1	scalpello piatto normale 125 mm	34
18	chiavi combinate 6-22 - 24 mm	42
8	chiavi a forchetta 6x7 - 8x9 - 10x11 - 12x13 - 14x15 - 16x17 - 18x19 - 20x22 mm	55
3	chiavi poligonali curve 12x13 - 14x15 - 17x19 mm	90
13	chiavi maschio esagonale piegate 2+10 - 12 mm	96
3	chiavi a bussola Macchina 1/2", 17 - 19 - 22 mm	720
1	quadro maschio a T snodato 3/8"	910/40
20	chiavi a bussola esagonali 1/2", 10+24 - 26 - 27 - 28 - 30 - 32 mm	920A
1	prolunga 125 mm - 1/2"	920/21
1	prolunga 255 mm - 1/2"	920/22
1	snodo 1/2"	920/25
1	quadro maschio 1/2" con spina scorrevole	920/42
1	cricchetto reversibile 1/2"	920/55
4	chiavi a bussola con impugnatura, tipo lungo 6 - 7 - 8 - 10 mm	943BM
10	chiavi a T con bussola snodata	952
	6 - 7 - 8 - 10 - 11 - 12 - 13 - 14 - 17 - 19 mm	
3	chiavi a bussola per candele 3/8", 16 - 17,8 - 20,8 mm	956E
1	leva con estremità a punta e a becco	964
1	pinza becchi dritti per anelli elastici, per fori 180 mm	1032
1	pinza becchi piegati per anelli elastici, per fori 170 mm	1034
1	pinza becchi dritti per anelli elastici, per alberi 175 mm	1036
1	pinza becchi piegati per anelli elastici, per alberi 175 mm	1038
1	pinza regolabile cerniera chiusa 240 mm	1048
1	pinza regolabile autobloccante 240 mm	1052
1	pinza autobloccante becchi lunghi 180 mm	1058
1	tronchese a taglienti diagonali 160 mm	1082BM
1	forbici per elettricisti lame diritte	1128BMX
1	pinza universale 180 mm	1150BM
1	pinza a becchi mezzotondi dritti 160 mm	1166BM
1	giravite provacircuito	1262
6	giravite lama piatta 3x75 - 3,5x100 - 4x125 5,5x150 - 6,5x200 - 10x200 mm	1270
1	giravite nano lama piatta 6,5x30 mm	1270N
3	giravite Phillips® PH0x60 - PH1x80 - PH2x100 mm	1272
1	giravite nano Phillips® PH2x30 mm	1272N
5	chiavi maschio per viti con impronta Torx® T8 - T10 - T15 - T20 - T25	1277TX
1	martello tipo tedesco 300 g	1370
1	mazzuola antirimbazzo Ø 35 mm	1392
1	pinza molle freni 210 mm	1470
1	pinza per capicorda non isolati	1603
1	flessometro 5 m	1691A/5
1	spessimetro a 20 lame	1708/20
1	flessibile magnetico 1,8 kg	1712E/2
6	lime ad ago 160 mm	1720/B6
1	oliatore in plastica a pressione 150 cc	1754

5957VG/2

Assortimento di 185 utensili

Autoriparazione



36,6 kg

5957VG/2 059570150

5700A O/VG2 057000072
(C57A O+5957VG/2)

5700A G/VG2 057000272
(C57A G+5957VG/2)

5700A R/VG2 057000472
(C57A R+5957VG/2)

5700B O/VG2 057000074
(C57B O+5957VG/2)

5700B G/VG2 057000274
(C57B G+5957VG/2)

5700B R/VG2 057000474
(C57B R+5957VG/2)

N. pezzi/Descrizione

N. pezzi/Descrizione	Beta N.
6 cacciapina con supporto Ø 2 - 3 - 4 - 5 - 6 - 8 mm	31/SP6
2 punzoni, 1 bulino, 3 scalpelli con supporto	38/SP6
19 chiavi combinate 6+22 - 24 - 27 mm	42
12 chiavi poligonali curve 6x7 - 8x9 - 10x11 - 12x13 - 14x15 - 16x17 - 18x19 - 20x22 - 21x23 - 24x27 - 25x28 - 30x32 mm	90/S12X
7 chiavi maschio esagonale piegate 2,5+10 mm	96N/G7
12 chiavi maschio esagonale piegate 2+10 mm	96/SP12
13 chiavi maschio piegate per viti con impronta Torx® T6+T50	97TX/B13
5 chiavi maschio XZN® piegate M5+M12	98XZN/G5
1 chiave regolabile a rullino 250 mm	110
1 chiave dinamometrica a scatto 1/2" 40÷200 Nm	606/20
2 chiavi a bussola Macchina 1/2", 17 - 19 mm	720
13 chiavi a bussola poligonali 1/2" con guida 10+22 mm	920B/SB13
8 chiavi a bussola poligonali 1/2" con guida 23+32 mm	920B/SB8
4 chiavi a bussola giravite lama piatta 1/2", 1,2x6,5 - 1,2x8 - 1,6x9 - 2x12 mm	920LP
3 chiavi a bussola giravite lama Phillips® PH2 - 3 - 4	920PH
1 prolunga 125 mm - 1/2"	920/21
1 prolunga 255 mm - 1/2"	920/22
1 snodo 1/2"	920/25
1 quadro maschio snodato 1/2" con impugnatura	920/35A
1 quadro maschio 1/2" con spina scorrevole	920/42
1 crocchetto reversibile 1/2"	920/55
7 chiavi a T con bussola snodata 8 - 10 - 11 - 13 - 14 - 17 - 19 mm	952
2 chiavi a T con bussola snodata per candele 16 - 20,8 mm	959
1 leva con estremità a punta e piatta curva	963
1 chiave a croce 17x19x22x 1/2"	979
1 pinzetta punte fini curve 130 mm	991
1 pinzetta punte larghe diritte 150 mm	994
2 pinze becchi diritti per anelli elastici, per fori 140 - 180 mm	1032
2 pinze becchi piegati per anelli elastici, per fori 130 - 170 mm	1034
2 pinze becchi diritti per anelli elastici, per alberi 140x1,3 - 175 mm	1036
2 pinze becchi piegati per anelli elastici, per alberi 135x1,3 - 175 mm	1038
1 pinza regolabile cerniera chiusa 240 mm	1048
1 pinza autobloccante a doppia regolazione	1051
1 tronchese a grande effetto taglienti diagonali 160 mm	1084BM
1 tronchese doppia leva taglio frontale 180 mm	1092V
1 cesoia a lame larghe diritte 250 mm	1112
1 cesoia a lame strette diritte 200 mm	1114
1 forbici per elettricisti lame diritte	1128BMX
1 pinza universale 180 mm	1150BM
1 pinza becchi piatti diritti 160 mm	1166BM
1 pinza becchi mezzotondi piegati 200 mm	1168BM
7 giravite lama piatta 3x75 - 3,5x100 - 4x125 - 5,5x150 - 6,5x200 - 10x200 - 12x250 mm	1270
1 giravite lama piatta con esagono di manovra 12x200 mm	1270E
3 giravite Phillips® PH0x60 - PH1x80 - PH2x100 mm	1272
2 martelli tipo tedesco 300 - 600 g	1370
1 mazzuola con battente in materiale plastico Ø 35 mm	1390
7 estrattori per prigionieri in cassetta 6+12 mm	1434/C7
1 chiave regolabile a nastro per filtri olio	1491
1 provatensione	1498
1 flessometro 5 m	1691A/5
1 spessimetro a 20 lame	1708/20
1 flessibile magnetico 1,8 kg	1712E/2
1 raschietto a due taglienti 200 mm	1717A
1 raschietto a tre taglienti 200 mm	1717B
5 lime taglio mezzodolce 200 mm	1719BMA/S5
1 seghetto	1725
1 oliatore in metallo a pressione 200 cc	1751
1 cutter con lama a settori	1771

Termoformati morbidi serie M



Assortimenti di utensili in termoformato per tutti i modelli di cassettiere e per i carrelli.

Per maggior chiarezza indichiamo le altezze dei cassetti C1 e C2 alle quali si deve fare riferimento per la scelta del termoformato completo di utensili. A fianco di ogni termoformato è indicato con quale altezza di cassetto è compatibile.

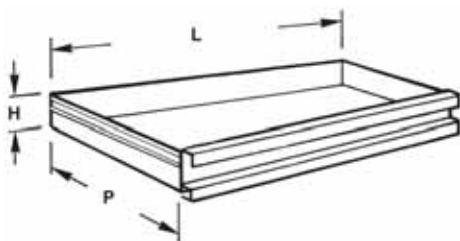

	H mm	LxP mm
C1	50	588x367
C2	80	588x367

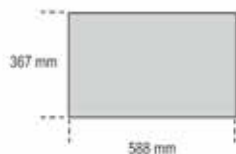
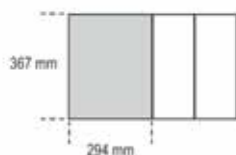
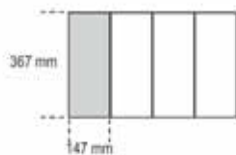

M15



42
6-7-8-9-10-11-12
13-14-15-16-17
18-19-20-21 mm

1500 g

C2



M15	1	024500015
MV15	1	024510015

M16



42
22-24-27-30-32 mm

2100 g

C2



M16	1	024500016
MV16	1	024510016

M35



55
6x7-8x9-10x11
12x13-14x15
16x17-18x19
20x22 mm
○96/SP9 1,5+10 mm

1100 g

C2



M35	1	024500035
MV35	1	024510035

M38



55
21x23-24x26
27x29-30x32 mm

1700 g

C1-C2



M38	1	024500038
MV38	1	024510038

M40



90
6x7-8x9-10x11
12x13-14x15
16x17-18x19 mm

810 g

C2



M40	1	024500040
MV40	1	024510040

M45



142
8-9-10-11-12
13-14-15-16
17-18-19 mm

1300 g

C2



M45	1	024500045
MV45	1	024510045

M46



142SN
8-9-10-11-12
13-14-15-16
17-18-19 mm

1400 g

C2



M46	1	024500046
MV46	1	024510046

M50



○96T
2-2,5-3-4-5
6-7-8 mm

1300 g

C1-C2



M50	1	024500050
MV50	1	024510050

M63



952 7-8-10-12-13-14-17-19 mm

3400 g

C1-C2

M63	1	024500063
MV63	1	024510063

M75



933 7-8-9-10-11-12-13-14-15
16-17-18-19-21-22-24 mm

5500 g

C2

M75	1	024500075
MV75	1	024510075

M82



920A 10-11-12-13-14
15-16-17-18-19
20-21-22-23-24
26-27-30-32 mm

920/ME 5-6-8-10-12 mm

920AN/125 125 mm

920/22 255 mm

920/25

920/42

920/55

4100 g

C2

M82	1	024500082
MV82	1	024510082

M90



900 4-4,5-5-5,5-6-7-8-9-
10-11-12-13-14 mm

900ME 2,5-3-4-5-6-8 mm

900/20 50 mm □ 1/4 - ■ 1/4

900/21 150 mm □ 1/4 - ■ 1/4

900/25 □ 1/4 - ■ 1/4

900/30 ■ 1/4

900/42 ■ 1/4

900/55 ■ 1/4

560 g

14"

C1 - C2

M90	1	024500090
MV90	1	024510090

M92



910A 6-7-8-9-10-11-12-13-
14-15-16-17-18-19-
20-21-22 mm

910/21 125 mm □ 3/8 - ■ 3/8

910/22 250 mm □ 3/8 - □ 3/8

910/25 □ 3/8 - ■ 3/8

910/42 ■ 3/8

910/55 ■ 3/8

1,5 kg

38"

C2

M92	1	024500092
MV92	1	024510092

M131



1084BM 160 mm

1150BM 180 mm

1166BM 160 mm

750 g

C1-C2

M131	1	024500131
MV131	1	024510131

M145



1032 180 mm

1034 170 mm

1036 175 mm

1038 175 mm

640 g

C1-C2

M145	1	024500145
MV145	1	024510145

M149



1048 240 mm

1052 240 mm

1000 g

C1-C2

M149	1	024500149
MV149	1	024510149

M170



1290 2,5x50
3x75
3,5x100
4x125
5,5x100
5,5x150
6,5x150 mm

450 g

C1-C2

M170	1	024500170
MV170	1	024510170

M172



1292 PH0x60
PH0x100
PH1x80
PH1x120
PH2x100
PH2x150 mm

450 g

C1-C2

M172	1	024500172
MV172	1	024510172

M234



35 100-200 mm

1370 300 g

1390 Ø 35 mm

1300 g

C1-C2

M234	1	024500234
MV232	1	024510232

M236



1719BMA/Q 200 mm

1719BMA/T 200 mm

1719BMA/P 200 mm

1719BMA/M 200 mm

1719BMA/R 200 mm

870 g

C1 - C2

M236	1	024500236
MV236	1	024510236

Termoformati rigidi serie T



Assortimenti di utensili in termoformato per tutti i modelli di cassettiere e per i carrelli.

Per maggior chiarezza indichiamo le altezze dei cassetti C1 e C2 alle quali si deve fare riferimento per la scelta del termoformato completo di utensili. A fianco di ogni termoformato è indicato con quale altezza di cassetto è compatibile.

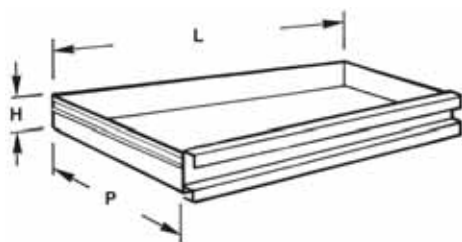

	H mm	LxP mm
C1	50	588x367
C2	80	588x367

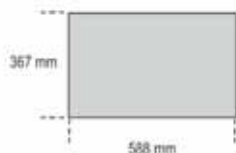
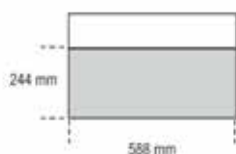
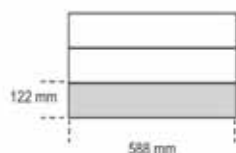
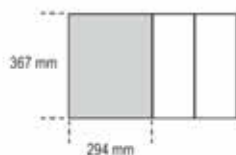
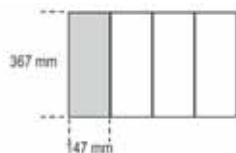

T10



42 6-7-8-10-11-12-13
14-16-17-18-19-21
22-24-27-30 mm

2710 g

C2



T10	1	024240010
TV10	1	024000400

T15



42 6-7-8-9-10-11-12
13-14-15-16-17
18-19-20-21 mm

1500 g

C2



T15	1	024240015
TV15	1	024000445

T16



42 22-24-27-30-32 mm

2100 g

C2



T16	1	024240016
TV16	1	024000446

T18



42MP 6-7-8-9-10-11-12
13-14-15-16-17
18-19-20-21 mm

1500 g

C2



T18	1	024240018
TV15	1	024000445

T19



42MP 22-24-27-30-32 mm

2100 g

C2



T19	1	024240019
TV16	1	024000446

T20



42AS 5/16-3/8-7/16-1/2
9/16-5/8-11/16-3/4
Ø96AS/PL7 3/32-1/8-5/32-3/16
1/4-5/16-3/8

1040 g

C2



T20	1	024240020
TV20	1	024000488

T21



42AS 13/16-7/8-15/16
1-1.1/16

2100 g

C2



T21	1	024240021
TV16	1	024000446

T30



31 Ø 2-3-4-5-6 mm
32 Ø 4 mm
55 6x7-8x9-10x11
12x13-14x15
16x17-18x19
20x22-21x23
24x26-27x29
30x32 mm
Ø96N/SP9 1,5+10 mm

2940 g

C2



T30	1	024240030
TV30	1	024000401

T35

55
 6x7-8x9-10x11
 12x13-14x15
 16x17-18x19
 20x22 mm
 ○96/SP9 1,5+10 mm

1050 g



T35 1 024240035
 TV20 1 024000488

T45

142
 8-9-10-11-12
 13-14-15-16
 17-18-19 mm

1300 g



T45 1 024240045
 TV45 1 024000498

T52

○96T 2-2,5-3-4-5-6 mm

350 g



T52 1 024240052
 TV52 1 024000473

T36

55MP
 6x7-8x9-10x11
 12x13-14x15
 16x17-18x19
 20x22 mm
 ○96/SP9 1,5+10 mm

1050 g



T36 1 024240036
 TV20 1 024000488

T46

142SN
 8-9-10-11-12
 13-14-15-16
 17-18-19 mm

1450 g



T46 1 024240046
 TV46 1 024000499

T53

○96TBP 2,5-3-4-5-6 mm

300 g



T53 1 024240053
 TV52 1 024000473

T40

90
 6x7-8x9-10x11
 12x13-14x15
 16x17-18x19 mm

810 g



T40 1 024240040
 TV40 1 024000456

T47

○96BPC/SP9 1,5+10 mm
 142C 8-9-10-11-12
 13-14-15-16
 17-18-19 mm

1400 g



T47 1 024240047
 TV47 1 024000763

T55

○97TTX T10-T15-T20
 T25-T27-T30

330 g



T55 1 024240055
 TV55 1 024000479

T41

90
 20x22-21x23
 24x26-25x28
 27x29 mm

1550 g



T41 1 024240041
 TV41 1 024000457

T50

○96T 2-2,5-3-3,5-4-4,5
 5-6-7-8-10 mm

1300 g



T50 1 024240050
 TV50 1 024000412



T60



110	250 mm
920/40	■ 1/2
951	2,5-3-4-5-6-8 mm
953	4-5-6-8 mm
1370	300 - 500 g

4160 g

C2



T60	1	024240060
TV60	1	024000420

T61



952	8-10-13-17-19 mm
959	16 mm (5/8") - 20,8 mm (13/16")
1270	3x75-4x100-5,5x100 6,5x150-10x200 mm
1272	PH0x60-PH1x80 PH2x100-PH3x150 mm

4960 g

C1 - C2



T61	1	024240061
TV61	1	024000721

T62



952	8-10-13-17-19 mm
959	16 mm (5/8") - 20,8 mm (13/16")
1290	3x75-4x100-5,5x100 6,5x150-10x200 mm
1292	PH0x60-PH1x80 PH2x100-PH3x150 mm

4980 g

C1 - C2



T62	1	024240062
TV61	1	024000721



T63



952	7-8-10-12-13-14-17-19 mm
-----	--------------------------

3430 g

C1 - C2



T63	1	024240063
TV63	1	024000471

T64



952FTX	E10-E12-E14
953TX	T25-T27-T30-T40-T45

2420 g

C1 - C2



T64	1	024240064
TV63	1	024000471

T65



953	3-3,5-4-5-6-7-8-10 mm
-----	-----------------------

2510 g

C1 - C2



T65	1	024240065
TV63	1	024000471

T68



951	2,5-3-4-5-6-8 mm
-----	------------------

590 g

C1 - C2



T68	1	024240068
TV68	1	024000470

T73



930	6x7-8x9-10x11-12x13- 14x15-16x17-18x19- 20x22 mm
-----	--

1,3 kg

C2



T73	1	024240073
TV73	1	024000418

T75



933	7-8-9-10-11-12-13 14-15-16-17-18-19 21-22-24 mm
-----	---

4155 g

C2



T75	1	024240075
TV75	1	024000422



T76



- 932 7-8-9-10-11-12-13
14-15-16-17-18-19
21-22-24 mm

4155 g

C2



T76	1 024240076
TV75	1 024000422

T77



- 933 6-7-8-10-11-12-13
14-17-19 mm

1440 g

C2



T77	1 024240077
TV77	1 024000474

T79



- 80 8x9-10x11-12x13
14x15-16x17
18x19 mm

1300 g

C2



T79	1 024240079
TV79	1 024000490

T80



- 920A 10-11-12-13-14
15-16-17-18-19
20-21-22-23-24
26-27-30-32 mm
- 920ME 5-6-8-10-12 mm
- 920/21 125 mm
- 920/22 255 mm
- 920/25 305 mm
- 920/42 305 mm
- 920/55 305 mm

4100 g

12"

C2



T80	1 024240080
TV80	1 024000403

T81



- 920B 10-11-12-13-14
15-16-17-18-19
20-21-22-23-24
26-27-30-32 mm
- 920ME 5-6-8-10-12 mm
- 920/21 125 mm
- 920/22 255 mm
- 920/25 305 mm
- 920/42 305 mm
- 920/55 305 mm

4050 g

12"

C2



T81	1 024240081
TV80	1 024000403

T82



- 920A 10-11-12-13-14
15-16-17-18-19
20-21-22-23-24
26-27-30-32 mm
- 920ME 5-6-8-10-12 mm
- 920AN/125 125 mm
- 920AN/250 250 mm
- 920/25 305 mm
- 920/42 305 mm
- 920/55 305 mm

4100 g

12"

C2



T82	1 024240082
TV80	1 024000403

T90



- 900 4-4.5-5-5.5-6
7-8-9-10-11
12-13-14 mm
- 900ME 2.5-3-4-5-6-8 mm
- 900/20 50 mm
- 900/21 150 mm
- 900/25 150 mm
- 900/30 150 mm
- 900/42 115 mm
- 900/55 115 mm

560 g

14"

C1 - C2



T90	1 024240090
TV90	1 024000447

T92



- 910A 6-7-8-9-10-11-12-13
14-15-16-17-18-19
20-21-22 mm
- 910/21 125 mm
- 910/22 250 mm
- 910/25 250 mm
- 910/42 210 mm
- 910/55 210 mm

1550 g

38"

C2



T92	1 024240092
TV92	1 024000458

T100



- 920A 10-12-13-14-15
16-17-18-19-21
22-24 mm
- 920/21 125 mm
- 920/25 305 mm
- 920/42 305 mm
- 920/55 305 mm

2110 g

12"

C2



T100	1 024240100
TV100	1 024000495

T101



- 920B 10-12-13-14-15
16-17-18-19-21
22-24 mm
- 920/21 125 mm
- 920/25 305 mm
- 920/42 305 mm
- 920/55 305 mm

2110 g

12"

C2



T101	1 024240101
TV100	1 024000495

T102



- 920AS 3/8-7/16-1/2
9/16-5/8-11/16
3/4-13/16-7/8
15/16-1.1/16
- 920/21 125 mm
- 920/25 305 mm
- 920/42 305 mm
- 920/55 305 mm

2110 g

12"

C2



T102	1 024240102
TV100	1 024000495



T105

928A 22-24-27-30-32-34
36-38-41-46-50 mm

4900 g

34"

C2



T105 1 024240105
TV105 1 024000484

T113

920PE 5L-6L-7L-8L-10L
920TX T40L-T45L
T55L-T70L
920XZN M6L-M8L-M12L

1450 g

12"

C2



T113 1 024240113
TV113 1 024000489

T131

1084BM 160 mm
1150BM 180 mm
1166BM 160 mm

750 g



T131 1 024240131
TV130 1 024000451

T106

928/21 200 mm
928/22 380 mm
928/42 450 mm
928/55

4460 g

34"

C2



T106 1 024240106
TV106 1 024000485

T115

910/21 125 mm
910/22 250 mm
910AN/75 75 mm
910AN/125 125 mm
910AN/250 250 mm

790 g

38"

C2



T115 1 024240115
TV115 1 024000417

T132

1084 160 mm
1150 180 mm
1166 160 mm

650 g



T132 1 024240132
TV130 1 024000451

T110

720 10-11-12-13-14
16-17-18-19-21
22-23-24 mm
720/21 125 mm

1830 g

12"

C2



T110 1 024240110
TV110 1 024000477

T116

920/20 75 mm
920/21 125 mm
920/22 255 mm
920AN/125 125 mm
920AN/250 250 mm

1240 g

12"

C2



T116 1 024240116
TV115 1 024000417

T135

1082MQ 160 mm
1150MQ 180 mm
1166MQ 160 mm

750 g



T135 1 024240135
TV135 1 024000762

△1000 V

T112

861TX ●1/4-T6+T15
866TX ●5/16-T20+T55
895/1 ○1/4x□1/4
895/6 ○5/16x□1/2
900FTX □1/4-E4+E10
920FTX □1/2-E12+E24
920TX □1/2-T55L-T60-T70L

1320 g

C2



T112 1 024240112
TV112 1 024000480

T120

606/20 200 Nm

1080 g

12"

C2



T120 1 024240120
TV120 1 024000483

T140

1032 140 - 180 mm
1034 170 mm
1036 140x1,3 - 175 mm
1038 175 mm
1084 160 mm
1128BM

1140 g



T140 1 024240140
TV140 1 024000405

T143

1048	240 mm
1052	240 mm
1112	250 mm
1150	180 mm

1760 g

C1 - C2

T143	1	024240143
TV143	1	024000409

T149

1048	240 mm
1052	240 mm

1000 g

C1 - C2

T149	1	024240149
TV150	1	024000462

T165

1270	3x75
	3x100
	4x100
	4x150
	5,5x100
	5,5x150
	6,5x150
	8x150
	10x200 mm
1270N	4x30
	6,5x30 mm

880 g

C1 - C2

T165	1	024240165
TV160	1	024000706

T145

1032	180 mm
1034	170 mm
1036	175 mm
1038	175 mm

640 g

C1 - C2

T145	1	024240145
TV145	1	024000448

T150

1047	240 mm
1057	240 mm

1300 g

C2

T150	1	024240150
TV150	1	024000462

T166

1272	PH0x60
	PH0x100
	PH1x80
	PH1x120
	PH2x100
	PH2x150
	PH3x150 mm
1272N	PH1x30
	PH2x30 mm

710 g

C1 - C2

T166	1	024240166
TV161	1	024000707

T146

1032	140 mm
1032	225 mm
1036	140x1,3 mm
1036	225 mm

700 g

C1 - C2

T146	1	024240146
TV146	1	024000449

T160**Betamax**

1290	3x75
	3x100
	4x100
	4x150
	5,5x100
	5,5x150
	6,5x150
	8x150
	10x200 mm
1290N	4x30
	6,5x30 mm

1120 g

C1 - C2

T160	1	024240160
TV160	1	024000706

T170**Betamax**

1290	2,5x50
	3x75
	3,5x100
	4x125
	5,5x100
	5,5x150
	6,5x150 mm

450 g

C1 - C2

T170	1	024240170
TV170	1	024000741

T147

1048	240 mm
1084BM	160 mm
1150BM	180 mm

800 g

C1 - C2

T147	1	024240147
TV148	1	024000500

T161**Betamax**

1292	PH0x60
	PH0x100
	PH1x80
	PH1x120
	PH2x100
	PH2x150
	PH3x150 mm
1292N	PH1x30
	PH2x30 mm

720 g

C1 - C2

T161	1	024240161
TV161	1	024000707

T171**Betamax**

1290	8x150
	8x200
	10x200 mm
1290N	4x30
	6,5x30 mm

750 g

C1 - C2

T171	1	024240171
TV171	1	024000742

T172

- 1292 PH0x60
PH0x100
PH1x80
PH1x120
PH2x100
PH2x150 mm

450 g



- T172 1 024240172
- TV172 1 024000743

T177

- 1298RTX T9-T10-T15
T20-T25-T27
T30-T40

680 g



- T177 1 024240177
- TV177 1 024000759

T191

- 1270 8x200
10x150
10x200 mm
- 1270N 4x30
6,5x30 mm

680 g



- T191 1 024240191
- TV171 1 024000742

T173

- 1292 PH3x150
PH4x200 mm
- 1292N PH1x30
PH2x30 mm

560 g



- T173 1 024240173
- TV173 1 024000744

T180

- 1290 3x75
4x100
5,5x150
6,5x150 mm
- 1292 PH0x60
PH1x80
PH2x100 mm

480 g



- T180 1 024240180
- TV180 1 024000701

T192

- 1272 PH0x60
PH0x100
PH1x80
PH1x120
PH2x100
PH2x150 mm

490 g



- T192 1 024240192
- TV172 1 024000743

T175

- 1297TX T6-T7-T8-T9
T10-T15-T20

410 g



- T175 1 024240175
- TV175 1 024000760

T183

- 1292L PH1x400-PH2x400 mm
- 1294L 3x300-4x400-5x400 mm

580 g



- T183 1 024240183
- TV183 1 024000497

T193

- 1272 PH3x150
PH4x200 mm
- 1272N PH1x30
PH2x30 mm

610 g



- T193 1 024240193
- TV173 1 024000744

T176

- 1297TX T25-T27-T30
T40-T45

640 g



- T176 1 024240176
- TV176 1 024000761

T190

- 1270 2,5x50
3x75
3,5x100
4x125
5,5x100
5,5x150
6,5x150 mm

490 g



- T190 1 024240190
- TV170 1 024000741

T195

- 1277TX T6-T7-T8-T9
T10-T15-T20

460 g



- T195 1 024240195
- TV175 1 024000760

T196

1277TX T25-T27-T30
T40-T45

710 g

C1 - C2

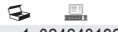

T196 1 024240196
TV176 1 024000761

T210

1201 2,5x50
3x75
3,5x100
4x125
5,5x100
5,5x150
6,5x150 mm

490 g

C1 - C2



T210 1 024240210
TV170 1 024000741

T225

1274MQ 3x100
4x100
5,5x125
6,5x150 mm
1272MQ PH0x60
PH1x80
PH2x100 mm

1000 V

460 g

C1 - C2



T225 1 024240225
TV180 1 024000701

T197

1278RTX T9-T10-T15
T20-T25-T27
T30-T40

760 g

C1 - C2



T197 1 024240197
TV177 1 024000759

T212

1202 PH0x60
PH1x80
PH1x120
PH2x100
PH2x150
PH3x150 mm

490 g

C1 - C2



T212 1 024240212
TV212 1 024000440

T231

1370 400 g
1390 Ø 35 mm
1719BMA/T 200 mm
1719BMA/P 200 mm
1719BMA/M 200 mm

1650 g

C2



T231 1 024240231
TV230 1 024000411

T200

1270 3x75
4x100
5,5x150
6,5x150 mm
1272 PH0x60
PH1x80
PH2x100 mm

530 g

C1 - C2



T200 1 024240200
TV180 1 024000701

T215

1207TX T6-T7-T8-T9
T10-T15-T20

410 g

C1 - C2



T215 1 024240215
TV175 1 024000760

T233

35 100-200 mm
1370F 32 mm
1390 Ø 35 mm

1300 g

C1 - C2



T233 1 024240233
TV232 1 024000452

T203

1272L PH1x400-PH2x400 mm
1274L 3x300-4x400-5x400 mm

580 g

C2



T203 1 024240203
TV183 1 024000497

T220

1201 3x75
4x100
5,5x150
6,5x150 mm
1202 PH0x60
PH1x80
PH2x100 mm

530 g

C1 - C2



T220 1 024240220
TV180 1 024000701

T234

35 100-200 mm
1370 300 g
1390 Ø 35 mm

1300 g

C1 - C2



T234 1 024240234
TV232 1 024000452



T255

Automotive



956E	16 mm (5/8) - 20,8 mm (13/16)
956L	16 mm (5/8) - 20,8 mm (13/16)
959	16 mm (5/8) - 20,8 mm (13/16)
1474	200 mm
1708/20	0,05+1 mm

3180 g

C2



T255	1	024240255
TV255	1	024000467

T261

Automotive



920B	□ 1/2-13-14-17-19 mm
920TX	□ 1/2-T55
1491	∅ 65+110 mm
1494	■ 8 x ■ 10 mm ○ 8 mm x 3/8" ○ 10x11 mm ○ 12x13 mm ○ 14x17 mm ○ 19 mm
1494PB	□ 1/2-17 mm
1496C	■ 8 x ■ 10 mm

1420 g

C2



T261	1	024240261
TV261	1	024000466

T263



96BP	2,5-3-4-5 6-8-10 mm
96N	12 mm
861MIX/S31	
895/1	

450 g

C2



T263	1	024240263
TV263	1	024000492

T236



- 1719BMA/Q 200 mm
- ▲ 1719BMA/T 200 mm
- ▨ 1719BMA/P 200 mm
- ▶ 1719BMA/M 200 mm
- 1719BMA/R 200 mm

870 g

C1-C2



T236	1	024240236
TV235	1	024000453

T241



- 1500N/1
- 1500N/3
- 1516/1

4200 g

C2



T241	1	024240241
TV241	1	024000414

T250

Automotive



34	150 mm
83/S3	11x13-14x17 19x22 mm
1458	175 mm
1491	
1603	
1708/13	0,05+1 mm

1430 g

C1 - C2



T250	1	024240250
TV250	1	024000408



T270



430	M3 - 4 - 5 - 6 - 7 - 8 - 9 10 - 12 - 14 - 16 - 18 - 20
433	M6x0,75 - M8x1 - M10x1,25 M12x1,5 - M14x1,5 M16x1,5 - M18x1,5
440	M3 - 4 - 5 - 6 - 7 - 8 - 9
440A	M10 - 12 - 14 - 16 - 18 - 20
441	M6x0,75 - M8x1,0
441A	M10x1,25 - M12x1,5 M14x1,5 - M16x1,5 M18x1,5

4280 g

C2



T270	1	024240270
TV270	1	024000481

T273



435/1,5	M3+M12
435/3	M5+M21
436/1	□ 2,0+5,0 mm (M3+M8)
436/2	□ 4,6+8 mm (M5+M12)
444/1	∅ 25,4 mm
444/2	∅ 38,1 mm
1707	W 62+4x1"

2100 g

C2



T273	1	024240273
TV272	1	024000482

T280



1741	250 mm
1741RV	2,9x6 mm (100)
1741RV	3,2x8 mm (100)
1741RV	3,8x10 mm (100)
1741RV	4x12 mm (100)
1741RV	4,8x12 mm (100)

1420 g

C2



T280	1	024240280
TV280	1	024000478



T285



1112	250 mm
1128BM	-
1726	400 mm
1728BM	(5)
1753	200 cc

1550 g



T285	1	024240285
TV285	1	024000487

T290



1692B/5	5 m
1725CR	-
1755	30 cc
1771	-

500 g



T290	1	024240290
TV290	1	024000455

T295



1650	-
1682	300 mm
1707	-
1708/20	0,05+1 mm

490 g



T295	1	024240295
TV295	1	024000454

VP1 - VP2

termoformati portaminuterie in materiale plastico per tutti i modelli di cassettiere: C22, C23, C23C

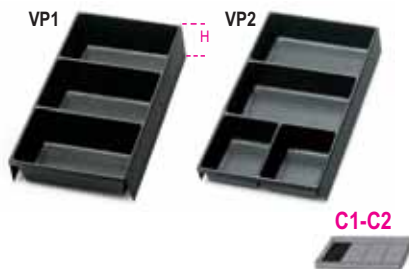

	H mm		
VP1	50	1	088880351
VP2	35	1	088880352

VP3 - VP4

termoformati portaminuterie in materiale plastico per tutti i modelli di cassettiere e per i carrelli

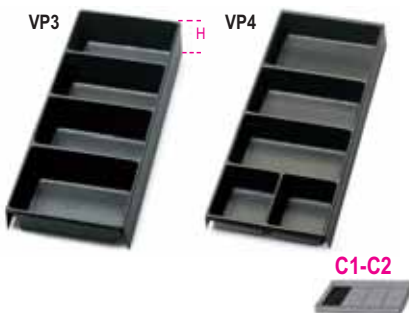

	H mm		
VP3	50	1	088880353
VP4	35	1	088880354

VP5

termoformato



VP5	1	088880355
-----	---	-----------

VP6

termoformato



VP6	1	088880359
-----	---	-----------

VP-3SC

termoformati portaminuterie in materiale plastico per cassettiere C38



	H mm		
VP-3SC	45	1	088880356

VP-LS

termoformati portaminuterie in materiale plastico per cassettiere C38



	H mm		
VP-LS	45	1	088880357

VP-LD

termoformati portaminuterie in materiale plastico per cassettiere C38



	H mm		
VP-LD	45	1	088880358

GA/C38-C

guida angolare per C38



GA/C38-C	5	088880370
----------	---	-----------

GA/C38-SX

guida angolare per C38



GA/C38-SX	5	088880372
-----------	---	-----------

GA/C38-DX

guida angolare per C38



GA/C38-DX	5	088880371
-----------	---	-----------

Beta



SL/C38

separatore longitudinale per C38



SL/C38 5 088880381

ST/C38-C

separatore trasversale per C38



ST/C38-C 5 088880391

ST/C38-SX

separatore trasversale per C38



ST/C38-SX 5 088880393

ST/C38-DX

separatore trasversale per C38



ST/C38-DX 5 088880392

GA/C41

guida angolare per C41

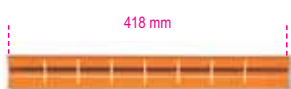

GA/C41 5 088880340

SL/C41

separatore longitudinale per C41



SL/C41 5 088880341

ST/C41

separatore trasversale per C41



ST/C41 5 088880346

Separatori per cassettiere e per carrelli



	H mm	LxP mm
C1	50	588x367
C2	80	588x367

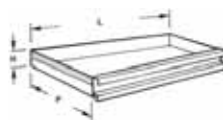

Separatori per cassettiere:
C22, C23, C23C



	H mm	LxP mm
C3	50	588x257
C4	80	588x257

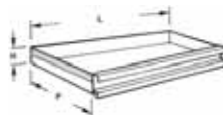

GA

guida angolare



GA 10 088880300

SL1 - SL2

separatori longitudinali



SL1 10 088880301
SL2 10 088880302

SL3 - SL4

separatori longitudinali



SL3 10 088880303
SL4 10 088880304

ST1 - ST2

separatori trasversali



ST1 10 088880311
ST2 10 088880312

GL1 - GL2

combinazioni di separatori paralleli



GL1 1 088880321
GL2 1 088880322

GL3 - GL4

combinazioni di separatori paralleli



GL3 1 088880323
GL4 1 088880324

TL1 - TL2

combinazioni di separatori incrociati



TL1 1 088880331
TL2 1 088880332

TL3 - TL4

combinazioni di separatori incrociati



TL3 1 088880333
TL4 1 088880334

SB

guide portabussole



	L mm	
SB1	210	10 088880201
SB2	280	10 088880202
SB3	360	10 088880203

MB

molle per guide SB



	□		
MB0	1/4	50	088880210
MB1	3/8	50	088880211
MB2	1/2	50	088880212

TV - TOV

pannello in lamiera forata



con sostegno			
TV		2	088880001
46x75 cm			
senza sostegno			
TOV		2	088880002
46x75 cm			

KIT/GPS

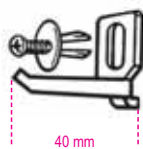

KIT/GPS		10	088880119
---------	--	----	-----------

VE1



VE1		20	088880120
-----	--	----	-----------

GM



∅			
mm			
6,5		5	088880250
9,5		5	088880251
13		5	088880252
16		5	088880253
19		5	088880254
25		5	088880255

S55/8

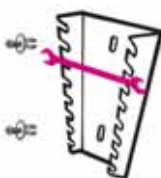

S55/8		1	088880400
55-55MP:	6x7-8x9-10x11		
	12x13-14x15-16x17		
	18x19-20x22 mm		

S55/12

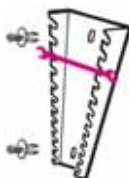

S55/12		1	088880401
55-55MP:	6x7-8x9-10x11		
	12x13-14x15-16x17		
	18x19-20x22-21x23		
	24x26-25x28-30x32 mm		

TSP

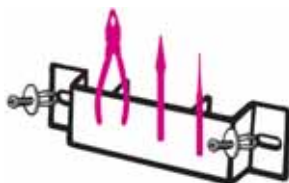

TSP		1	088880402
-----	--	---	-----------

S952

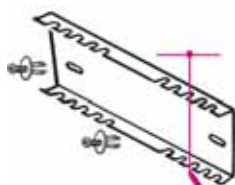

S952		1	088880403
952:	6-7-8-10-11		
	12-13-14-17-19 mm		

S1719BM



S1719BM		1	088880404
1719BMA:	Q-T-P-M-R		

SGN



SGN		1	088880405
1290N-1292N-1299N/PZ			
1270N-1272N-1277N/TX-1279N/PZ			

CB/2

solo per C54

12"

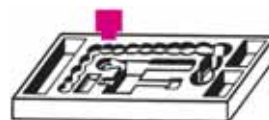

CB/2		1	088880411
920A/920B			
10=24+26-27			
28-30-32 mm			

S42/18

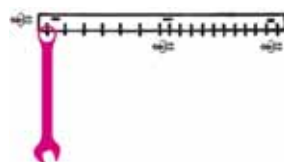

S42/18		1	088880408
42-42MP:	6=22+24 mm		
42-42MP:	6=14+16-17		
	18-19-21-22-24-27-30 mm		

S951/6

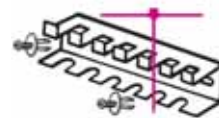

S951/6		1	088880409
951:	2,5-3-4-5-6-8 mm		

SP G9 - SP G11



SP G9		1	088880909
n.6 ∅ = 7 mm			
n.2 ∅ = 10 mm			
n.1 ∅ = 12 mm			
SP G11		1	088880910
n.8 ∅ = 7 mm			
n.2 ∅ = 10 mm			
n.1 ∅ = 12 mm			

96/SPV



96/SPV		1	000960400
--------	--	---	-----------

96T/SPV

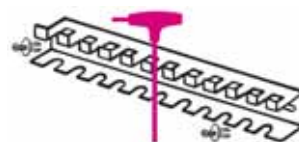

96T/SPV		1	000960958
---------	--	---	-----------



UTENSILI ANTISCINTILLA

RAME-BERILLIO
Cu-Be



Gli utensili Antiscintilla **Beta** sono specifici per operare in assoluta sicurezza in ambienti a potenziale rischio di esplosioni, con presenza di liquidi o gas infiammabili, o per applicazioni che richiedono l'utilizzo di utensili perfettamente antimagnetici e altamente resistenti alla corrosione.

Composizione	Be	1,8 ÷ 2,3 %
	Co+Ni	Min 0,2 %
	Co+Ni+Fe	Max 1,2 %
	Cu	A compensazione
Durezza	310 ÷ 360 Brinell	
Resistenza alla trazione	1050 ÷ 1200 N/mm ²	
Limite di snervamento	840 ÷ 880 N/mm ²	

31BA

punzoni antiscintilla,
in lega Rame/Berillio



Ø mm	L mm		
8	150	1	000310808
10	150	1	000310810
12	150	1	000310812

34BA

scalpelli piatti antiscintilla,
in lega Rame/Berillio



L mm	A mm		
200	22	1	000340801
300	24	1	000340802

39BA

cunei antiscintilla,
in lega Rame/Berillio



L mm	A mm		
150	40	1	000390801
230	40	1	000390802

42BA

chiavi combinate antiscintilla,
in lega Rame/Berillio



Ø mm	L mm		
6x6	105	1	000420806
7x7	105	1	000420807
8x8	120	1	000420808
9x9	120	1	000420809
10x10	135	1	000420810
11x11	135	1	000420811
12x12	150	1	000420812
13x13	150	1	000420813
14x14	175	1	000420814
15x15	175	1	000420815
16x16	195	1	000420816
17x17	200	1	000420817
19x19	220	1	000420819
20x20	230	1	000420820
21x21	240	1	000420821
22x22	250	1	000420822
24x24	268	1	000420824
27x27	290	1	000420827
30x30	313	1	000420830
32x32	333	1	000420832
36x36	355	1	000420836

Ø mm	L mm		
38x38	430	1	000420838
41x41	430	1	000420841
46x46	480	1	000420846
50x50	520	1	000420850
55x55	560	1	000420855
60x60	580	1	000420860

42BA/AS

chiavi combinate antiscintilla,
in lega Rame/Berillio



Ø mm	L mm		
3/8x3/8	128	1	000420950
7/16x7/16	135	1	000420951
1/2x1/2	140	1	000420953
9/16x9/16	163	1	000420954
5/8x5/8	177	1	000420956
11/16x11/16	195	1	000420957
3/4x3/4	215	1	000420959
13/16x13/16	230	1	000420961
7/8x7/8	235	1	000420962
15/16x15/16	256	1	000420964
1x1	266	1	000420965
1.1/16x1.1/16	283	1	000420967
1.1/8x1.1/8	297	1	000420969
1.3/16x1.3/16	308	1	000420970
1.1/4x1.1/4	324	1	000420973

55BA

chiavi a forchetta doppie antiscintilla
in lega Rame/Berillio



Ø mm	L mm		
6x7	90	1	000550801
8x9	100	1	000550802
10x11	120	1	000550803
12x13	130	1	000550804
14x15	145	1	000550805
16x17	165	1	000550807
18x19	170	1	000550809
20x22	185	1	000550811
21x23	210	1	000550813
22x24	210	1	000550815
24x26	230	1	000550817
24x27	230	1	000550818
25x28	230	1	000550819
27x29	246	1	000550820
30x32	265	1	000550822
36x38	320	1	000550826
41x46	355	1	000550829

78BA

chiavi poligonali a percussione
antiscintilla, in lega Rame/Berillio



Ø mm	L mm		
24	140	1	000780824
27	155	1	000780827
30	165	1	000780830

Ø mm	L mm		
32	180	1	000780832
34	192	1	000780834
36	208	1	000780836
38	215	1	000780838
41	225	1	000780841
46	245	1	000780846
50	250	1	000780850
55	265	1	000780855
60	275	1	000780860
65	295	1	000780865
70	310	1	000780870
75	325	1	000780875
80	340	1	000780880

78BA/AS

chiavi poligonali a percussione antiscintilla,
in lega Rame/Berillio



Ø mm	L mm		
1.1/4	177	1	000780910
1.7/16	208	1	000780912
1.5/8	225	1	000780914
1.13/16	243	1	000780916
2	254	1	000780918
2.3/16	264	1	000780920
2.3/8	275	1	000780922
2.9/16	286	1	000780924
2.15/16	311	1	000780926
3.1/8	325	1	000780928
3.1/2	355	1	000780930

89BA

chiavi poligonali semplici
antiscintilla, in lega Rame/Berillio



Ø mm	L mm		
10	200	1	000890810
11	210	1	000890811
12	220	1	000890812
13	230	1	000890813
14	240	1	000890814
16	260	1	000890816
17	270	1	000890817
18	280	1	000890818
19	300	1	000890819
20	310	1	000890820
22	330	1	000890822
24	350	1	000890824
27	370	1	000890827
30	400	1	000890830
32	420	1	000890832

90BA

chiavi poligonali doppie antiscintilla,
in lega Rame/Berillio



Ø mm	L mm		
10x11	155	1	000900803
12x13	175	1	000900806
14x17	220	1	000900809

mm	L mm		
16x18	235	1	000900812
18x19	265	1	000900815
20x22	295	1	000900818
22x24	315	1	000900821
24x27	340	1	000900823
30x32	395	1	000900824
34x36	410	1	000900826

96BA

chiavi maschio esagonale piegate
antiscintilla, in lega Rame/Berillio



mm	L mm	L1 mm		
2	50	16	1	000960762
3	63	21	1	000960763
4	69	25	1	000960764
5	78	29	1	000960765
6	88	33	1	000960766
7	93	34	1	000960767
8	97	36	1	000960768
9	104	37	1	000960769
10	110	39	1	000960770
12	122	44	1	000960772

110BA

chiavi regolabili a rullino
antiscintilla, in lega Rame/Berillio



L mm	A max		
200	24	1	001100820
250	32	1	001100825
300	39	1	001100830
375	48	1	001100837

363BA

giratubi modello americano
antiscintilla, in lega Rame/Berillio



L mm	Ø max	Ø max mm		
250	1" gas	34	1	003630825
300	1 1/2" gas	49	1	003630830
350	2" gas	60	1	003630835
450	2 1/2" gas	76	1	003630845
600	3" gas	90	1	003630860

386BA

giratubi reversibili a catena
modello pesante antiscintilla,
in lega Rame/Berillio



Ø max mm	L mm		
100	600	1	003860806
200	900	1	003860809

921BA

chiavi a bussola poligonali antiscintilla,
in lega Rame/Berillio

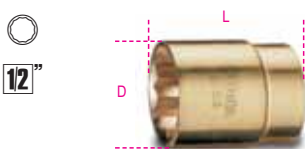

mm	D mm	L mm		
10	16,5	40	1	009210810
11	17,5	40	1	009210811
12	18,5	40	1	009210812
13	19,5	40	1	009210813
14	20,0	40	1	009210814
15	21,5	40	1	009210815
16	24,0	40	1	009210816
17	25,0	40	1	009210817
18	25,0	40	1	009210818
19	28,0	42	1	009210819
20	29,0	42	1	009210820
21	30,0	43	1	009210821
22	30,5	43	1	009210822
24	34,0	43	1	009210824
25	36,0	43	1	009210825
26	37,5	43	1	009210826
27	37,5	45	1	009210827
28	38,9	46	1	009210828
30	41,5	46	1	009210830
32	43,5	46	1	009210832

921BA/50

cricchetto semplice
con quadro scorrevole 1/2"
antiscintilla, in lega Rame/Berillio



L mm	D mm	A mm		
250	45	16,5	1	009210850

963BA

leva con estremità a punta
e piatta curva antiscintilla,
in lega Rame/Berillio



L mm	A mm		
500	24	1	009630801

964BA

aprifusti antiscintilla,
in lega Rame/Berillio



L mm			
385	1	009640801	

966BA

chiave di manovra antiscintilla,
in lega Rame/Berillio
per valvole di sicurezza

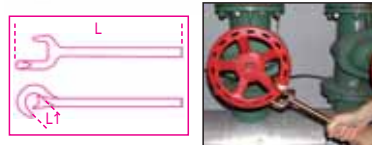

L mm	L1 mm		
350	40	1	009660801

1046BA

pinza regolabile antiscintilla,
in lega Rame/Berillio
cerniera a cremagliera



L mm	A max mm		
250	32	1	010460801

1082BA

tronchesi a taglianti diagonali
antiscintilla, in lega Rame/Berillio



L mm	L1 mm		
160	22	1	010820801

1150BA

pinza universale antiscintilla
in lega Rame/Berillio

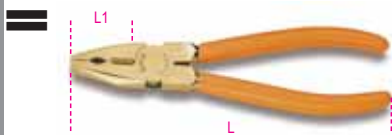

L
mm
200

L1
mm
40

1 011500820

1270BA

giravite per viti a testa con intaglio
antiscintilla,
in lega Rame/Berillio



AxL
mm

L1
mm

4x100

209

1 012700804

6x150

270

1 012700806

10x250

382

1 012700810

1272BA

giravite per viti
con impronta a croce Phillips®
antiscintilla, in lega Rame/Berillio



PHxDxL
mm

L1
mm

1x5x100

209

1 012720801

2x6x150

270

1 012720802

3x8x200

332

1 012720803

1370BA

martelli tipo tedesco antiscintilla,
in lega Rame/Berillio
manico in legno



g
500

L1
mm
108

L
mm
310

1 013700805

1000

137

340

1 013700810

1370BA/MR

manici di ricambio per 1370BA

1370BA/MR500
1370BA/500

1 013700865

1370BA/MR1000
1370BA/1000

1 013700870

1379BA

martello scrostatore antiscintilla,
in lega Rame/Berillio
manico in legno



g
500

L1
mm
142

L
mm
315

1 013790850

1380BA

mazzette antiscintilla,
in lega Rame/Berillio
manico in legno



g
1500

L1
mm
118

L
mm
397

1 013800815

2000

126

449

1 013800820

1380BA/MR

manici di ricambio per 1380BA

1380BA/MR1500

1380BA/1500

1 013800865

1380BA/MR2000

1380BA/2000

1 013800870

1381BA

mazza antiscintilla,
in lega Rame/Berillio
manico in legno

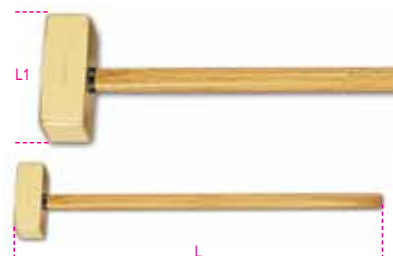

g
5000

L1
mm
179

L
mm
900

1 013810850

1381BA/MR

manico di ricambio per 1381BA

1381BA/MR5000

1381BA/5000

1 013810870

1717BA

spatole rigide antiscintilla,
in lega Rame/Berillio



A
mm

60

1 017170801

80

1 017170803

1717BA/1

raschiapareti antiscintilla,
in lega Rame/Berillio



1717BA/1

1 017170805

1727BA

seghetto e lama antiscintilla,
in lega Rame/Berillio



1727BA

1 017270801

1728BA

lama per segchetti antiscintilla,
in lega Rame/Berillio



1728BA

1 017280801

1737BA

spazzola con fili antiscintilla,
in lega Rame/Berillio



A
mm
29

1737BA

1 017370801

1776BA

coltello antiscintilla,
in lega Rame/Berillio



1776BA

1 017760801

CALZATURE DI SICUREZZA

Diverse ed interessanti le novità proposte da Beta Utensili per il listino 2010.

La linea "light racing" che si arricchisce dei modelli Mid in pieno fiore e scamosciati. (7323AK - 7324AK - 7325AK).

Le nuove trekking economiche in due versioni di colore e prodotte in pelle scamosciata

idrorepellente (7254N/A - 7255N/A - 7256N/A - 7257N/A).

Molto interessanti ed innovative le calzature della linea "manager" in pieno fiore con nuovi design e finiture (7300AKK - 7300BKK), oltre alla sportiva in denim e scamosciata (7300CKK).

Inoltre Beta Utensili presenta nella linea "heavy duty" il remake delle storiche 7290 e 7291 in pelle pieno fiore idrorepellente, impreziosite da puntale e lamina in materiale composito e dalla nuova suola "ice" (7290AKK - 7291AKK)

EN ISO



SAS



3D

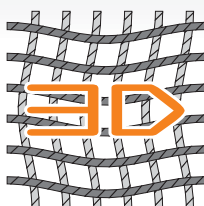

FRESH PLUS

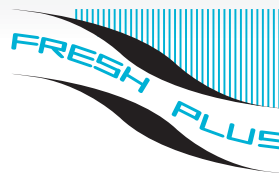

COMPOSITE INSOLE



PLASTIC TOE



ALUMINIUM TOE



LEATHER



BLOW FEET



WIDE BODY



Per facilitare l'identificazione delle caratteristiche tecniche delle calzature che più si addicono alle vostre esigenze vi consigliamo di prendere visione delle icone di seguito rappresentate.



Lamina od inserto antiperforazione.



Puntale in acciaio, in alluminio o in plastica.



Scarpa antistatica.



Assorbimento di energia nella zona del tallone.



Suola resistente agli oli, idrocarburi e solventi.



Suola antiscivolo.



Resistenza alle flessioni ripetute > 60.000.



Suola resistente al calore per contatto (300 °C/min.).

AVVERTENZE

CONTROLLI PRELIMINARI ED UTILIZZO

Prima dell'uso effettuare un controllo visivo dello stato generale della calzatura verificando cuciture, stato della suola e sistemi di chiusura, controllando inoltre che la calzatura abbia tutte le caratteristiche indicate

dall'etichetta, ed in special modo se la calzatura prevede puntale e lamina antiperforazione.

IMPIEGHI SCONSIGLIATI

Sono tassativamente sconsigliati gli impieghi

prolungati e/o ripetuti:

- a contatto con agenti organici, diserbanti, pesticidi ed acidi in forte concentrazione.
- a temperature estreme (oltre -10 °C e +70 °C).
- di immersione completa in acqua, fango, malte e similari.

7200NKK

scarpe in pelle pieno fiore
ad alta traspirazione



EU	UK	USA	J		
35	2,5	3	22	1	072000135
36	3,5	4	22,5	1	072000136
37	4,5	5	23	1	072000137
38	5	6	24	1	072000138
39	6	7	24,5	1	072000139
40	6,5	7,5	25,5	1	072000140
41	7	8,5	26,5	1	072000141
42	8	9	27	1	072000142
43	9	10	28	1	072000143
44	10	10,5	28,5	1	072000144
45	10,5	11,5	29,5	1	072000145
46	11	12	30	1	072000146
47	12	13	31	1	072000147
48	13	14	32	1	072000148



CE

EN 20345 S3

7201NKK

scarpe alte in pelle pieno fiore
ad alta traspirazione



EU	UK	USA	J		
35	2,5	3	22	1	072010135
36	3,5	4	22,5	1	072010136
37	4,5	5	23	1	072010137
38	5	6	24	1	072010138
39	6	7	24,5	1	072010139
40	6,5	7,5	25,5	1	072010140
41	7	8,5	26,5	1	072010141
42	8	9	27	1	072010142
43	9	10	28	1	072010143
44	10	10,5	28,5	1	072010144
45	10,5	11,5	29,5	1	072010145
46	11	12	30	1	072010146
47	12	13	31	1	072010147
48	13	14	32	1	072010148



CE

EN 20345 S3

7201N

scarpe alte in pelle pieno fiore ad alta traspirazione con rapido
sfilamento



EU	UK	USA	J		
38	5	6	24	1	072010238
39	6	7	24,5	1	072010239
40	6,5	7,5	25,5	1	072010240
41	7	8,5	26,5	1	072010241
42	8	9	27	1	072010242
43	9	10	28	1	072010243
44	10	10,5	28,5	1	072010244
45	10,5	11,5	29,5	1	072010245
46	11	12	30	1	072010246
47	12	13	31	1	072010247
48	13	14	32	1	072010248



CE

EN 20345 S3

7202N

scarpe alte in pelle ad alta traspirazione
con rapido sfilamento



EU	UK	USA	J		
38	5	6	24	1	072020138
39	6	7	24,5	1	072020139
40	6,5	7,5	25,5	1	072020140
41	7	8,5	26,5	1	072020141
42	8	9	27	1	072020142
43	9	10	28	1	072020143
44	10	10,5	28,5	1	072020144
45	10,5	11,5	29,5	1	072020145
46	11	12	30	1	072020146
47	12	13	31	1	072020147
48	13	14	32	1	072020148



CE

EN 20345 S1P

7203N

scarpe in pelle
ad alta traspirazione



EU	UK	USA	J	Icon	Icon
38	5	6	24	1	072030138
39	6	7	24,5	1	072030139
40	6,5	7,5	25,5	1	072030140
41	7	8,5	26,5	1	072030141
42	8	9	27	1	072030142
43	9	10	28	1	072030143
44	10	10,5	28,5	1	072030144
45	10,5	11,5	29,5	1	072030145
46	11	12	30	1	072030146
47	12	13	31	1	072030147
48	13	14	32	1	072030148



CE

EN 20345 S1P

7204N

scarpe alte in pelle
ad alta traspirazione



EU	UK	USA	J	Icon	Icon
38	5	6	24	1	072040138
39	6	7	24,5	1	072040139
40	6,5	7,5	25,5	1	072040140
41	7	8,5	26,5	1	072040141
42	8	9	27	1	072040142
43	9	10	28	1	072040143
44	10	10,5	28,5	1	072040144
45	10,5	11,5	29,5	1	072040145
46	11	12	30	1	072040146
47	12	13	31	1	072040147
48	13	14	32	1	072040148



CE

EN 20345 S1P

7205NPK

scarpe in pelle pieno fiore
ad alta traspirazione con copripuntale
in poliuretano, ampia calzata



EU	UK	USA	J	Icon	Icon
38	5	6	24	1	072050138
39	6	7	24,5	1	072050139
40	6,5	7,5	25,5	1	072050140
41	7	8,5	26,5	1	072050141
42	8	9	27	1	072050142
43	9	10	28	1	072050143
44	10	10,5	28,5	1	072050144
45	10,5	11,5	29,5	1	072050145
46	11	12	30	1	072050146
47	12	13	31	1	072050147
48	13	14	32	1	072050148



CE

EN 20345 S3

7206NPK

scarpe alte in pelle pieno fiore
ad alta traspirazione con copripuntale
in poliuretano, ampia calzata



EU	UK	USA	J	Icon	Icon
38	5	6	24	1	072060138
39	6	7	24,5	1	072060139
40	6,5	7,5	25,5	1	072060140
41	7	8,5	26,5	1	072060141
42	8	9	27	1	072060142
43	9	10	28	1	072060143
44	10	10,5	28,5	1	072060144
45	10,5	11,5	29,5	1	072060145
46	11	12	30	1	072060146
47	12	13	31	1	072060147
48	13	14	32	1	072060148

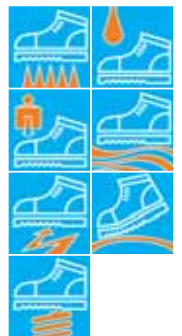

CE

EN 20345 S3

7207R

scarpe in pelle senza lamina antiperforazione
con suola in gomma



EU	UK	USA	J		
39	6	7	24,5		1 072070039
40	6,5	7,5	25,5		1 072070040
41	7	8,5	26,5		1 072070041
42	8	9	27		1 072070042
43	9	10	28		1 072070043
44	10	10,5	28,5		1 072070044
45	10,5	11,5	29,5		1 072070045
46	11	12	30		1 072070046
47	12	13	31		1 072070047

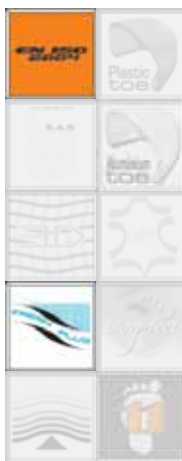

CE

EN 20345 S1 HRO

7207RK

scarpe in pelle pieno fiore
con suola in gomma



EU	UK	USA	J		
39	6	7	24,5		1 072070139
40	6,5	7,5	25,5		1 072070140
41	7	8,5	26,5		1 072070141
42	8	9	27		1 072070142
43	9	10	28		1 072070143
44	10	10,5	28,5		1 072070144
45	10,5	11,5	29,5		1 072070145
46	11	12	30		1 072070146
47	12	13	31		1 072070147



CE

EN 20345 S3 HRO

7208R

scarpe alte in pelle senza lamina antiperforazione
con suola in gomma



EU	UK	USA	J		
39	6	7	24,5		1 072080039
40	6,5	7,5	25,5		1 072080040
41	7	8,5	26,5		1 072080041
42	8	9	27		1 072080042
43	9	10	28		1 072080043
44	10	10,5	28,5		1 072080044
45	10,5	11,5	29,5		1 072080045
46	11	12	30		1 072080046
47	12	13	31		1 072080047

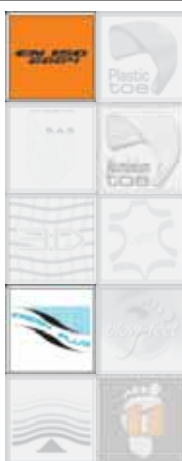

CE

EN 20345 S1 HRO

7208RK

scarpe alte in pelle pieno fiore
con suola in gomma



EU	UK	USA	J		
39	6	7	24,5		1 072080139
40	6,5	7,5	25,5		1 072080140
41	7	8,5	26,5		1 072080141
42	8	9	27		1 072080142
43	9	10	28		1 072080143
44	10	10,5	28,5		1 072080144
45	10,5	11,5	29,5		1 072080145
46	11	12	30		1 072080146
47	12	13	31		1 072080147



CE

EN 20345 S3 HRO

7210N

scarpe in morbida pelle scamosciata, traforate



EU	UK	USA	J
35	2,5	3	22
36	3,5	4	22,5
37	4,5	5	23
38	5	6	24
39	6	7	24,5
40	6,5	7,5	25,5
41	7	8,5	26,5
42	8	9	27
43	9	10	28
44	10	10,5	28,5
45	10,5	11,5	29,5
46	11	12	30
47	12	13	31
48	13	14	32



1	072100135
1	072100136
1	072100137
1	072100138
1	072100139
1	072100140
1	072100141
1	072100142
1	072100143
1	072100144
1	072100145
1	072100146
1	072100147
1	072100148



CE



EN 20345 S1P



7211N

scarpe in morbida pelle scamosciata, senza lamina antiperforazione



EU	UK	USA	J
35	2,5	3	22
36	3,5	4	22,5
37	4,5	5	23
38	5	6	24
39	6	7	24,5
40	6,5	7,5	25,5
41	7	8,5	26,5
42	8	9	27
43	9	10	28
44	10	10,5	28,5
45	10,5	11,5	29,5
46	11	12	30
47	12	13	31
48	13	14	32



1	072110135
1	072110136
1	072110137
1	072110138
1	072110139
1	072110140
1	072110141
1	072110142
1	072110143
1	072110144
1	072110145
1	072110146
1	072110147
1	072110148



CE



EN 20345 S1



7216N

sandali in morbida pelle scamosciata con chiusura a strappo



EU	UK	USA	J
35	2,5	3	22
36	3,5	4	22,5
37	4,5	5	23
38	5	6	24
39	6	7	24,5
40	6,5	7,5	25,5
41	7	8,5	26,5
42	8	9	27
43	9	10	28
44	10	10,5	28,5
45	10,5	11,5	29,5
46	11	12	30
47	12	13	31



1	072160135
1	072160136
1	072160137
1	072160138
1	072160139
1	072160140
1	072160141
1	072160142
1	072160143
1	072160144
1	072160145
1	072160146
1	072160147



CE



EN 20345 S1P



7223NK

scarpe in morbido Nabuk ingrassato



EU	UK	USA	J
35	2,5	3	22
36	3,5	4	22,5
37	4,5	5	23
38	5	6	24
39	6	7	24,5
40	6,5	7,5	25,5
41	7	8,5	26,5
42	8	9	27
43	9	10	28
44	10	10,5	28,5
45	10,5	11,5	29,5
46	11	12	30
47	12	13	31



1	072230035
1	072230036
1	072230037
1	072230038
1	072230039
1	072230040
1	072230041
1	072230042
1	072230043
1	072230044
1	072230045
1	072230046
1	072230047



CE



EN 20345 S3



7224NK

scarpe alte in morbido Nabuk ingrassato



EU	UK	USA	J		
35	2,5	3	22	1	072240035
36	3,5	4	22,5	1	072240036
37	4,5	5	23	1	072240037
38	5	6	24	1	072240038
39	6	7	24,5	1	072240039
40	6,5	7,5	25,5	1	072240040
41	7	8,5	26,5	1	072240041
42	8	9	27	1	072240042
43	9	10	28	1	072240043
44	10	10,5	28,5	1	072240044
45	10,5	11,5	29,5	1	072240045
46	11	12	30	1	072240046
47	12	13	31	1	072240047
				1	072240047



CE

EN 20345 S3

7225WK

mocassini in Lorica idrorepellente senza lamina antiperforazione



EU	UK	USA	J		
36	3,5	4	22,5	1	072250036
37	4,5	5	23	1	072250037
38	5	6	24	1	072250038
39	6	7	24,5	1	072250039
40	6,5	7,5	25,5	1	072250040
41	7	8,5	26,5	1	072250041
42	8	9	27	1	072250042
43	9	10	28	1	072250043
44	10	10,5	28,5	1	072250044
45	10,5	11,5	29,5	1	072250045
46	11	12	30	1	072250046
47	12	13	31	1	072250047
48	13	14	32	1	072250048



CE

EN 20345 S2

7226WK

scarpe in microfibra idrorepellente senza lamina antiperforazione



EU	UK	USA	J		
36	3,5	4	22,5	1	072260036
37	4,5	5	23	1	072260037
38	5	6	24	1	072260038
39	6	7	24,5	1	072260039
40	6,5	7,5	25,5	1	072260040
41	7	8,5	26,5	1	072260041
42	8	9	27	1	072260042
43	9	10	28	1	072260043
44	10	10,5	28,5	1	072260044
45	10,5	11,5	29,5	1	072260045
46	11	12	30	1	072260046
47	12	13	31	1	072260047
48	13	14	32	1	072260048



CE

EN 20345 S1

7227WK

scarpe in microfibra idrorepellente senza lamina antiperforazione



EU	UK	USA	J		
36	3,5	4	22,5	1	072270036
37	4,5	5	23	1	072270037
38	5	6	24	1	072270038
39	6	7	24,5	1	072270039
40	6,5	7,5	25,5	1	072270040
41	7	8,5	26,5	1	072270041
42	8	9	27	1	072270042
43	9	10	28	1	072270043
44	10	10,5	28,5	1	072270044
45	10,5	11,5	29,5	1	072270045
46	11	12	30	1	072270046
47	12	13	31	1	072270047
48	13	14	32	1	072270048



CE

EN 20345 S1

7228NWK

scarpe in microfibra idrorepellente
senza lamina antiperforazione



EU	UK	USA	J
36	3,5	4	22,5
37	4,5	5	23
38	5	6	24
39	6	7	24,5
40	6,5	7,5	25,5
41	7	8,5	26,5
42	8	9	27
43	9	10	28
44	10	10,5	28,5
45	10,5	11,5	29,5
46	11	12	30
47	12	13	31
48	13	14	32



1	072280036
1	072280037
1	072280038
1	072280039
1	072280040
1	072280041
1	072280042
1	072280043
1	072280044
1	072280045
1	072280046
1	072280047
1	072280048



CE

EN 20345 S2

7229WK

scarpe in microfibra idrorepellente
senza lamina antiperforazione



EU	UK	USA	J
36	3,5	4	22,5
37	4,5	5	23
38	5	6	24
39	6	7	24,5
40	6,5	7,5	25,5
41	7	8,5	26,5
42	8	9	27
43	9	10	28
44	10	10,5	28,5
45	10,5	11,5	29,5
46	11	12	30
47	12	13	31
48	13	14	32



1	072290036
1	072290037
1	072290038
1	072290039
1	072290040
1	072290041
1	072290042
1	072290043
1	072290044
1	072290045
1	072290046
1	072290047
1	072290048



CE

EN 20345 S2

7240CM

scarpe in pelle
senza lamina antiperforazione



EU	UK	USA	J
38	5	6	24
39	6	7	24,5
40	6,5	7,5	25,5
41	7	8,5	26,5
42	8	9	27
43	9	10	28
44	10	10,5	28,5
45	10,5	11,5	29,5
46	11	12	30
47	12	13	31
48	13	14	32



1	072400138
1	072400139
1	072400140
1	072400141
1	072400142
1	072400143
1	072400144
1	072400145
1	072400146
1	072400147
1	072400148

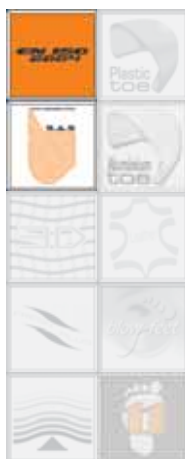

CE

EN 20345 S1

7241CM

scarpe in pelle
con lamina antiperforazione



EU	UK	USA	J
38	5	6	24
39	6	7	24,5
40	6,5	7,5	25,5
41	7	8,5	26,5
42	8	9	27
43	9	10	28
44	10	10,5	28,5
45	10,5	11,5	29,5
46	11	12	30
47	12	13	31
48	13	14	32



1	072410138
1	072410139
1	072410140
1	072410141
1	072410142
1	072410143
1	072410144
1	072410145
1	072410146
1	072410147
1	072410148

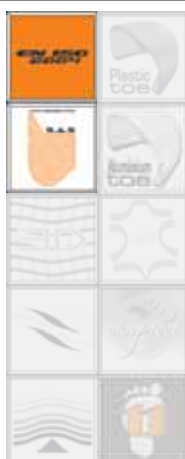

CE

EN 20345 S1P

7242CM

scarpe alte in pelle
senza lamina antiperforazione



EU	UK	USA	J		
38	5	6	24		1 072420138
39	6	7	24,5		1 072420139
40	6,5	7,5	25,5		1 072420140
41	7	8,5	26,5		1 072420141
42	8	9	27		1 072420142
43	9	10	28		1 072420143
44	10	10,5	28,5		1 072420144
45	10,5	11,5	29,5		1 072420145
46	11	12	30		1 072420146
47	12	13	31		1 072420147
48	13	14	32		1 072420148

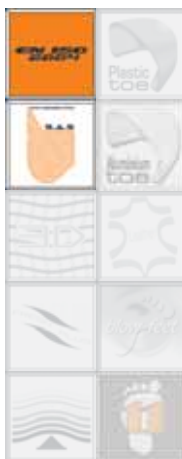

CE

EN 20345 S1

7243CM

scarpe alte in pelle
con lamina antiperforazione



EU	UK	USA	J		
38	5	6	24		1 072430138
39	6	7	24,5		1 072430139
40	6,5	7,5	25,5		1 072430140
41	7	8,5	26,5		1 072430141
42	8	9	27		1 072430142
43	9	10	28		1 072430143
44	10	10,5	28,5		1 072430144
45	10,5	11,5	29,5		1 072430145
46	11	12	30		1 072430146
47	12	13	31		1 072430147
48	13	14	32		1 072430148

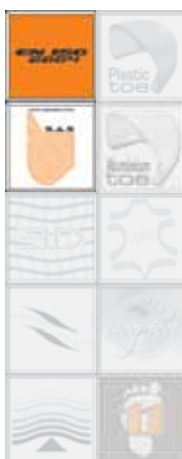

CE

EN 20345 S1P

7244CM

scarpe alte in pelle, a rapido sfilamento,
con lamina antiperforazione



EU	UK	USA	J		
38	5	6	24		1 072440138
39	6	7	24,5		1 072440139
40	6,5	7,5	25,5		1 072440140
41	7	8,5	26,5		1 072440141
42	8	9	27		1 072440142
43	9	10	28		1 072440143
44	10	10,5	28,5		1 072440144
45	10,5	11,5	29,5		1 072440145
46	11	12	30		1 072440146
47	12	13	31		1 072440147
48	13	14	32		1 072440148

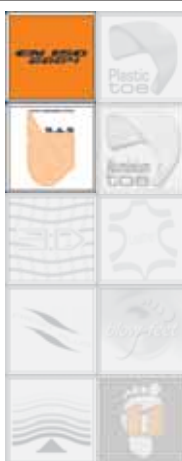

CE

EN 20345 S1P

7245CM

scarpe alte con protezione frontale
e chiusura a strappo



EU	UK	USA	J		
38	5	6	24		1 072450138
39	6	7	24,5		1 072450139
40	6,5	7,5	25,5		1 072450140
41	7	8,5	26,5		1 072450141
42	8	9	27		1 072450142
43	9	10	28		1 072450143
44	10	10,5	28,5		1 072450144
45	10,5	11,5	29,5		1 072450145
46	11	12	30		1 072450146
47	12	13	31		1 072450147
48	13	14	32		1 072450148



CE

EN 20345 S1P

7246CM

scarpe in pelle scamosciata traforate



EU	UK	USA	J
35	2,5	3	22
36	3,5	4	22,5
37	4,5	5	23
38	5	6	24
39	6	7	24,5
40	6,5	7,5	25,5
41	7	8,5	26,5
42	8	9	27
43	9	10	28
44	10	10,5	28,5
45	10,5	11,5	29,5
46	11	12	30
47	12	13	31
48	13	14	32



1	072460135
1	072460136
1	072460137
1	072460138
1	072460139
1	072460140
1	072460141
1	072460142
1	072460143
1	072460144
1	072460145
1	072460146
1	072460147
1	072460148



CE

EN 20345 S1P

7250NK

scarpe in pelle scamosciata con inserti in airnet



EU	UK	USA	J
38	5	6	24
39	6	7	24,5
40	6,5	7,5	25,5
41	7	8,5	26,5
42	8	9	27
43	9	10	28
44	10	10,5	28,5
45	10,5	11,5	29,5
46	11	12	30
47	12	13	31



1	072500138
1	072500139
1	072500140
1	072500141
1	072500142
1	072500143
1	072500144
1	072500145
1	072500146
1	072500147



CE

EN 20345 S1P

7251NK

scarpe alte in pelle scamosciata con inserti in airnet



EU	UK	USA	J
38	5	6	24
39	6	7	24,5
40	6,5	7,5	25,5
41	7	8,5	26,5
42	8	9	27
43	9	10	28
44	10	10,5	28,5
45	10,5	11,5	29,5
46	11	12	30
47	12	13	31



1	072510138
1	072510139
1	072510140
1	072510141
1	072510142
1	072510143
1	072510144
1	072510145
1	072510146
1	072510147



CE

EN 20345 S1P

7254N/A

scarpe in pelle scamosciata idrorepellente con inserti in nylon



EU	UK	USA	J
38	5	6	24
39	6	7	24,5
40	6,5	7,5	25,5
41	7	8,5	26,5
42	8	9	27
43	9	10	28
44	10	10,5	28,5
45	10,5	11,5	29,5
46	11	12	30
47	12	13	31



1	072540138
1	072540139
1	072540140
1	072540141
1	072540142
1	072540143
1	072540144
1	072540145
1	072540146
1	072540147



CE

EN 20345 S3

7255N/A

scarpe alte in pelle scamosciata idrorepellente con inserti in nylon

EU	UK	USA	J	
38	5	6	24	1 072550138
39	6	7	24,5	1 072550139
40	6,5	7,5	25,5	1 072550140
41	7	8,5	26,5	1 072550141
42	8	9	27	1 072550142
43	9	10	28	1 072550143
44	10	10,5	28,5	1 072550144
45	10,5	11,5	29,5	1 072550145
46	11	12	30	1 072550146
47	12	13	31	1 072550147



CE

EN 20345 S3

7256N/A

scarpe in pelle scamosciata idrorepellente con inserti in nylon

EU	UK	USA	J	
38	5	6	24	1 072560138
39	6	7	24,5	1 072560139
40	6,5	7,5	25,5	1 072560140
41	7	8,5	26,5	1 072560141
42	8	9	27	1 072560142
43	9	10	28	1 072560143
44	10	10,5	28,5	1 072560144
45	10,5	11,5	29,5	1 072560145
46	11	12	30	1 072560146
47	12	13	31	1 072560147



CE

EN 20345 S3

7257N/A

scarpe alte in pelle scamosciata idrorepellente con inserti in nylon

EU	UK	USA	J	
38	5	6	24	1 072570138
39	6	7	24,5	1 072570139
40	6,5	7,5	25,5	1 072570140
41	7	8,5	26,5	1 072570141
42	8	9	27	1 072570142
43	9	10	28	1 072570143
44	10	10,5	28,5	1 072570144
45	10,5	11,5	29,5	1 072570145
46	11	12	30	1 072570146
47	12	13	31	1 072570147



CE

EN 20345 S3

7263NK

scarpe in pelle scamosciata idrorepellente con inserti in mesh

EU	UK	USA	J	
38	5	6	24	1 072630038
39	6	7	24,5	1 072630039
40	6,5	7,5	25,5	1 072630040
41	7	8,5	26,5	1 072630041
42	8	9	27	1 072630042
43	9	10	28	1 072630043
44	10	10,5	28,5	1 072630044
45	10,5	11,5	29,5	1 072630045
46	11	12	30	1 072630046
47	12	13	31	1 072630047



CE

EN 20345 S3

7264NK

scarpe alte in pelle scamosciata
idrorepellente con inserti in mesh



EU	UK	USA	J	
38	5	6	24	1 072640038
39	6	7	24,5	1 072640039
40	6,5	7,5	25,5	1 072640040
41	7	8,5	26,5	1 072640041
42	8	9	27	1 072640042
43	9	10	28	1 072640043
44	10	10,5	28,5	1 072640044
45	10,5	11,5	29,5	1 072640045
46	11	12	30	1 072640046
47	12	13	31	1 072640047



CE

EN 20345 S3

7285NK

scarpe "relax" in morbida pelle
scamosciata, traforate



EU	UK	USA	J	
35	2,5	3	22	1 072850135
36	3,5	4	22,5	1 072850136
37	4,5	5	23	1 072850137
38	5	6	24	1 072850138
39	6	7	24,5	1 072850139
40	6,5	7,5	25,5	1 072850140
41	7	8,5	26,5	1 072850141
42	8	9	27	1 072850142
43	9	10	28	1 072850143
44	10	10,5	28,5	1 072850144
45	10,5	11,5	29,5	1 072850145
46	11	12	30	1 072850146
47	12	13	31	1 072850147



CE

EN 20345 S1P

7290AKK

scarpe in pelle pieno fiore idrorepellente
ad alta traspirazione



EU	UK	USA	J	
38	5	6	24	1 072900238
39	6	7	24,5	1 072900239
40	6,5	7,5	25,5	1 072900240
41	7	8,5	26,5	1 072900241
42	8	9	27	1 072900242
43	9	10	28	1 072900243
44	10	10,5	28,5	1 072900244
45	10,5	11,5	29,5	1 072900245
46	11	12	30	1 072900246
47	12	13	31	1 072900247
48	13	14	32	1 072900248



CE

EN 20345 S3

7291AKK

scarpe alte in pelle pieno fiore idrorepellente ad alta
traspirazione



EU	UK	USA	J	
38	5	6	24	1 072910238
39	6	7	24,5	1 072910239
40	6,5	7,5	25,5	1 072910240
41	7	8,5	26,5	1 072910241
42	8	9	27	1 072910242
43	9	10	28	1 072910243
44	10	10,5	28,5	1 072910244
45	10,5	11,5	29,5	1 072910245
46	11	12	30	1 072910246
47	12	13	31	1 072910247
48	13	14	32	1 072910248



CE

EN 20345 S3

7293NKK

scarpe in pelle Nabuk ingrassata
con dynamic control e suola in gomma VIBRAM®
ad alta resistenza



EU	UK	USA	J		
38	5	6	24	1	072930138
39	6	7	24,5	1	072930139
40	6,5	7,5	25,5	1	072930140
41	7	8,5	26,5	1	072930141
42	8	9	27	1	072930142
43	9	10	28	1	072930143
44	10	10,5	28,5	1	072930144
45	10,5	11,5	29,5	1	072930145
46	11	12	30	1	072930146
47	12	13	31	1	072930147
48	13	14	32	1	072930148



CE

EN 20345 S3 HRO

7293TKK

scarpe in pelle Nabuk ingrassata
con membrana in Thinsulate™, dynamic control e suola in
gomma VIBRAM® ad alta resistenza



EU	UK	USA	J		
38	5	6	24	1	072930238
39	6	7	24,5	1	072930239
40	6,5	7,5	25,5	1	072930240
41	7	8,5	26,5	1	072930241
42	8	9	27	1	072930242
43	9	10	28	1	072930243
44	10	10,5	28,5	1	072930244
45	10,5	11,5	29,5	1	072930245
46	11	12	30	1	072930246
47	12	13	31	1	072930247
48	13	14	32	1	072930248



CE

EN 20345 S3 HRO

7293RK

scarpe in pelle Nabuk ingrassata
con torsion control e suola in gomma ad alta resistenza



EU	UK	USA	J		
39	6	7	24,5	1	072930339
40	6,5	7,5	25,5	1	072930340
41	7	8,5	26,5	1	072930341
42	8	9	27	1	072930342
43	9	10	28	1	072930343
44	10	10,5	28,5	1	072930344
45	10,5	11,5	29,5	1	072930345
46	11	12	30	1	072930346
47	12	13	31	1	072930347



CE

EN 20345 S3 HRO

7294NKK

scarpe alte in pelle Nabuk ingrassata
con dynamic control e suola in gomma VIBRAM® ad alta
resistenza



EU	UK	USA	J		
38	5	6	24	1	072940138
39	6	7	24,5	1	072940139
40	6,5	7,5	25,5	1	072940140
41	7	8,5	26,5	1	072940141
42	8	9	27	1	072940142
43	9	10	28	1	072940143
44	10	10,5	28,5	1	072940144
45	10,5	11,5	29,5	1	072940145
46	11	12	30	1	072940146
47	12	13	31	1	072940147
48	13	14	32	1	072940148



CE

EN 20345 S3 HRO

7294TKK

scarpe alte in pelle Nabuk ingrassata con membrana in Thinsulate™, dynamic control e suola in gomma VIBRAM® ad alta resistenza



EU	UK	USA	J	EU	UK	USA	J
38	5	6	24	1	072940238		
39	6	7	24,5	1	072940239		
40	6,5	7,5	25,5	1	072940240		
41	7	8,5	26,5	1	072940241		
42	8	9	27	1	072940242		
43	9	10	28	1	072940243		
44	10	10,5	28,5	1	072940244		
45	10,5	11,5	29,5	1	072940245		
46	11	12	30	1	072940246		
47	12	13	31	1	072940247		
48	13	14	32	1	072940248		



CE

EN 20345 S3 HRO

7294RK

scarpe alte in pelle Nabuk ingrassata con torsion control e suola in gomma ad alta resistenza



EU	UK	USA	J	EU	UK	USA	J
39	6	7	24,5	1	072940339		
40	6,5	7,5	25,5	1	072940340		
41	7	8,5	26,5	1	072940341		
42	8	9	27	1	072940342		
43	9	10	28	1	072940343		
44	10	10,5	28,5	1	072940344		
45	10,5	11,5	29,5	1	072940345		
46	11	12	30	1	072940346		
47	12	13	31	1	072940347		



CE

EN 20345 S3 HRO

7300AKK

scarpe in pelle pieno fiore ad alta traspirazione



EU	UK	USA	J	EU	UK	USA	J
36	3,5	4	22,5	1	073000136		
37	4,5	5	23	1	073000137		
38	5	6	24	1	073000138		
39	6	7	24,5	1	073000139		
40	6,5	7,5	25,5	1	073000140		
41	7	8,5	26,5	1	073000141		
42	8	9	27	1	073000142		
43	9	10	28	1	073000143		
44	10	10,5	28,5	1	073000144		
45	10,5	11,5	29,5	1	073000145		
46	11	12	30	1	073000146		
47	12	13	31	1	073000147		
48	13	14	32	1	073000148		



CE

EN 20345 S3

7300BKK

scarpe in pelle pieno fiore ad alta traspirazione



EU	UK	USA	J	EU	UK	USA	J
36	3,5	4	22,5	1	073000236		
37	4,5	5	23	1	073000237		
38	5	6	24	1	073000238		
39	6	7	24,5	1	073000239		
40	6,5	7,5	25,5	1	073000240		
41	7	8,5	26,5	1	073000241		
42	8	9	27	1	073000242		
43	9	10	28	1	073000243		
44	10	10,5	28,5	1	073000244		
45	10,5	11,5	29,5	1	073000245		
46	11	12	30	1	073000246		
47	12	13	31	1	073000247		
48	13	14	32	1	073000248		



CE

EN 20345 S3

7300CKK

scarpe in denim con inserti in pelle scamosciata

EU	UK	USA	J		
36	3,5	4	22,5	1	073000336
37	4,5	5	23	1	073000337
38	5	6	24	1	073000338
39	6	7	24,5	1	073000339
40	6,5	7,5	25,5	1	073000340
41	7	8,5	26,5	1	073000341
42	8	9	27	1	073000342
43	9	10	28	1	073000343
44	10	10,5	28,5	1	073000344
45	10,5	11,5	29,5	1	073000345
46	11	12	30	1	073000346
47	12	13	31	1	073000347
48	13	14	32	1	073000348



CE

EN 20345 S1P

7302N

scarpe "FREE TIME" in morbida pelle scamosciata traforata, senza puntale e lamina antiperforazione

EU	UK	USA	J		
36	3,5	4	22,5	1	073020136
37	4,5	5	23	1	073020137
38	5	6	24	1	073020138
39	6	7	24,5	1	073020139
40	6,5	7,5	25,5	1	073020140
41	7	8,5	26,5	1	073020141
42	8	9	27	1	073020142
43	9	10	28	1	073020143
44	10	10,5	28,5	1	073020144
45	10,5	11,5	29,5	1	073020145
46	11	12	30	1	073020146
47	12	13	31	1	073020147
48	13	14	32	1	073020148



CE

EN 20347 O1

7302NKK

scarpe in morbida pelle scamosciata traforata

EU	UK	USA	J		
36	3,5	4	22,5	1	073020236
37	4,5	5	23	1	073020237
38	5	6	24	1	073020238
39	6	7	24,5	1	073020239
40	6,5	7,5	25,5	1	073020240
41	7	8,5	26,5	1	073020241
42	8	9	27	1	073020242
43	9	10	28	1	073020243
44	10	10,5	28,5	1	073020244
45	10,5	11,5	29,5	1	073020245
46	11	12	30	1	073020246
47	12	13	31	1	073020247
48	13	14	32	1	073020248



CE

EN 20345 S1P

7303N

scarpe "FREE TIME" in pelle pieno fiore ad alta traspirazione senza puntale e lamina antiperforazione

EU	UK	USA	J		
36	3,5	4	22,5	1	073030136
37	4,5	5	23	1	073030137
38	5	6	24	1	073030138
39	6	7	24,5	1	073030139
40	6,5	7,5	25,5	1	073030140
41	7	8,5	26,5	1	073030141
42	8	9	27	1	073030142
43	9	10	28	1	073030143
44	10	10,5	28,5	1	073030144
45	10,5	11,5	29,5	1	073030145
46	11	12	30	1	073030146
47	12	13	31	1	073030147
48	13	14	32	1	073030148



CE

EN 20347 O2

7303NKK

scarpe in pelle pieno fiore
ad alta traspirazione



EU	UK	USA	J
36	3,5	4	22,5
37	4,5	5	23
38	5	6	24
39	6	7	24,5
40	6,5	7,5	25,5
41	7	8,5	26,5
42	8	9	27
43	9	10	28
44	10	10,5	28,5
45	10,5	11,5	29,5
46	11	12	30
47	12	13	31
48	13	14	32



EU	UK	USA	J
1			
1			
1			
1			
1			
1			
1			
1			
1			
1			
1			
1			
1			
1			
1			



CE



EN 20345 S3

7304N

scarpe "FREE TIME" in pelle Nabuk
ingrassata senza puntale
e lamina antiperforazione



EU	UK	USA	J
36	3,5	4	22,5
37	4,5	5	23
38	5	6	24
39	6	7	24,5
40	6,5	7,5	25,5
41	7	8,5	26,5
42	8	9	27
43	9	10	28
44	10	10,5	28,5
45	10,5	11,5	29,5
46	11	12	30
47	12	13	31
48	13	14	32



EU	UK	USA	J
1			
1			
1			
1			
1			
1			
1			
1			
1			
1			
1			
1			
1			
1			
1			
1			



CE



EN 20347 O2

7304NKK

scarpe in pelle Nabuk ingrassata



EU	UK	USA	J
36	3,5	4	22,5
37	4,5	5	23
38	5	6	24
39	6	7	24,5
40	6,5	7,5	25,5
41	7	8,5	26,5
42	8	9	27
43	9	10	28
44	10	10,5	28,5
45	10,5	11,5	29,5
46	11	12	30
47	12	13	31
48	13	14	32



EU	UK	USA	J
1			
1			
1			
1			
1			
1			
1			
1			
1			
1			
1			
1			
1			
1			
1			
1			



CE



EN 20345 S3

7305

scarpe midi "FREE TIME" in pelle Nabuk
ingrassata senza puntale
e lamina antiperforazione



EU	UK	USA	J
36	3,5	4	22,5
37	4,5	5	23
38	5	6	24
39	6	7	24,5
40	6,5	7,5	25,5
41	7	8,5	26,5
42	8	9	27
43	9	10	28
44	10	10,5	28,5
45	10,5	11,5	29,5
46	11	12	30
47	12	13	31
48	13	14	32



EU	UK	USA	J
1			
1			
1			
1			
1			
1			
1			
1			
1			
1			
1			
1			
1			
1			
1			
1			



CE



EN 20347 O2

7307NKK

scarpe midi in pelle scamosciata
idrorepellente



EU	UK	USA	J		
36	3,5	4	22,5	1	073070036
37	4,5	5	23	1	073070037
38	5	6	24	1	073070038
39	6	7	24,5	1	073070039
40	6,5	7,5	25,5	1	073070040
41	7	8,5	26,5	1	073070041
42	8	9	27	1	073070042
43	9	10	28	1	073070043
44	10	10,5	28,5	1	073070044
45	10,5	11,5	29,5	1	073070045
46	11	12	30	1	073070046
47	12	13	31	1	073070047
48	13	14	32	1	073070048



CE

EN 20345 S3

7308NKK

scarpe midi in pelle pieno fiore bottalata



EU	UK	USA	J		
36	3,5	4	22,5	1	073080036
37	4,5	5	23	1	073080037
38	5	6	24	1	073080038
39	6	7	24,5	1	073080039
40	6,5	7,5	25,5	1	073080040
41	7	8,5	26,5	1	073080041
42	8	9	27	1	073080042
43	9	10	28	1	073080043
44	10	10,5	28,5	1	073080044
45	10,5	11,5	29,5	1	073080045
46	11	12	30	1	073080046
47	12	13	31	1	073080047
48	13	14	32	1	073080048



CE

EN 20345 S3

7311RK

scarpe "saldatore" in pelle
con suola in gomma e fibbia a rapido sfilamento



EU	UK	USA	J		
38	5	6	24	1	073110238
39	6	7	24,5	1	073110239
40	6,5	7,5	25,5	1	073110240
41	7	8,5	26,5	1	073110241
42	8	9	27	1	073110242
43	9	10	28	1	073110243
44	10	10,5	28,5	1	073110244
45	10,5	11,5	29,5	1	073110245
46	11	12	30	1	073110246
47	12	13	31	1	073110247



CE

EN 20345 S1P HRO

7313AK

scarpe "light" in pelle scamosciata
ed inserti in mesh, suola racing



EU	UK	USA	J		
36	3,5	4	22,5	1	073130036
37	4,5	5	23	1	073130037
38	5	6	24	1	073130038
39	6	7	24,5	1	073130039
40	6,5	7,5	25,5	1	073130040
41	7	8,5	26,5	1	073130041
42	8	9	27	1	073130042
43	9	10	28	1	073130043
44	10	10,5	28,5	1	073130044
45	10,5	11,5	29,5	1	073130045
46	11	12	30	1	073130046
47	12	13	31	1	073130047



CE

EN 20345 S1P

7313AK/B

scarpe "light" in pelle scamosciata ed inserti in mesh, suola racing

EU	UK	USA	J		
36	3,5	4	22,5	1	073130136
37	4,5	5	23	1	073130137
38	5	6	24	1	073130138
39	6	7	24,5	1	073130139
40	6,5	7,5	25,5	1	073130140
41	7	8,5	26,5	1	073130141
42	8	9	27	1	073130142
43	9	10	28	1	073130143
44	10	10,5	28,5	1	073130144
45	10,5	11,5	29,5	1	073130145
46	11	12	30	1	073130146
47	12	13	31	1	073130147



CE

EN 20345 S1P

7314AK

scarpe "light" in pelle scamosciata, suola racing

EU	UK	USA	J		
36	3,5	4	22,5	1	073140036
37	4,5	5	23	1	073140037
38	5	6	24	1	073140038
39	6	7	24,5	1	073140039
40	6,5	7,5	25,5	1	073140040
41	7	8,5	26,5	1	073140041
42	8	9	27	1	073140042
43	9	10	28	1	073140043
44	10	10,5	28,5	1	073140044
45	10,5	11,5	29,5	1	073140045
46	11	12	30	1	073140046
47	12	13	31	1	073140047



CE

EN 20345 S1P

7320AK

scarpe "light" in pelle scamosciata idrorepellente, suola racing

EU	UK	USA	J		
36	3,5	4	22,5	1	073200136
37	4,5	5	23	1	073200137
38	5	6	24	1	073200138
39	6	7	24,5	1	073200139
40	6,5	7,5	25,5	1	073200140
41	7	8,5	26,5	1	073200141
42	8	9	27	1	073200142
43	9	10	28	1	073200143
44	10	10,5	28,5	1	073200144
45	10,5	11,5	29,5	1	073200145
46	11	12	30	1	073200146
47	12	13	31	1	073200147



CE

EN 20345 S3

7323AK

scarpe "light" alte in pelle scamosciata idrorepellente, suola racing

EU	UK	USA	J		
36	3,5	4	22,5	1	073230036
37	4,5	5	23	1	073230037
38	5	6	24	1	073230038
39	6	7	24,5	1	073230039
40	6,5	7,5	25,5	1	073230040
41	7	8,5	26,5	1	073230041
42	8	9	27	1	073230042
43	9	10	28	1	073230043
44	10	10,5	28,5	1	073230044
45	10,5	11,5	29,5	1	073230045
46	11	12	30	1	073230046
47	12	13	31	1	073230047



CE

EN 20345 S3

7315AK

scarpe "light" in pelle scamosciata, suola racing

EU	UK	USA	J		
36	3,5	4	22,5	1	073150036
37	4,5	5	23	1	073150037
38	5	6	24	1	073150038
39	6	7	24,5	1	073150039
40	6,5	7,5	25,5	1	073150040
41	7	8,5	26,5	1	073150041
42	8	9	27	1	073150042
43	9	10	28	1	073150043
44	10	10,5	28,5	1	073150044
45	10,5	11,5	29,5	1	073150045
46	11	12	30	1	073150046
47	12	13	31	1	073150047



CE

EN 20345 S1P

7324AK

scarpe "light" alte in pelle scamosciata, suola racing

EU	UK	USA	J		
36	3,5	4	22,5	1	073240036
37	4,5	5	23	1	073240037
38	5	6	24	1	073240038
39	6	7	24,5	1	073240039
40	6,5	7,5	25,5	1	073240040
41	7	8,5	26,5	1	073240041
42	8	9	27	1	073240042
43	9	10	28	1	073240043
44	10	10,5	28,5	1	073240044
45	10,5	11,5	29,5	1	073240045
46	11	12	30	1	073240046
47	12	13	31	1	073240047



CE

EN 20345 S1P

7316AK

scarpe "light" in pelle pieno fiore bottalata idrorepellente, suola racing

EU	UK	USA	J		
36	3,5	4	22,5	1	073160036
37	4,5	5	23	1	073160037
38	5	6	24	1	073160038
39	6	7	24,5	1	073160039
40	6,5	7,5	25,5	1	073160040
41	7	8,5	26,5	1	073160041
42	8	9	27	1	073160042
43	9	10	28	1	073160043
44	10	10,5	28,5	1	073160044
45	10,5	11,5	29,5	1	073160045
46	11	12	30	1	073160046
47	12	13	31	1	073160047



CE

EN 20345 S3

7325AK

scarpe "light" alte in pelle pieno fiore bottalata idrorepellente, suola racing

EU	UK	USA	J		
36	3,5	4	22,5	1	073250036
37	4,5	5	23	1	073250037
38	5	6	24	1	073250038
39	6	7	24,5	1	073250039
40	6,5	7,5	25,5	1	073250040
41	7	8,5	26,5	1	073250041
42	8	9	27	1	073250042
43	9	10	28	1	073250043
44	10	10,5	28,5	1	073250044
45	10,5	11,5	29,5	1	073250045
46	11	12	30	1	073250046
47	12	13	31	1	073250047



CE

EN 20345 S3

7317AK

sandali "light" in pelle scamosciata, suola racing



EU	UK	USA	J
36	3,5	4	22,5
37	4,5	5	23
38	5	6	24
39	6	7	24,5
40	6,5	7,5	25,5
41	7	8,5	26,5
42	8	9	27
43	9	10	28
44	10	10,5	28,5
45	10,5	11,5	29,5
46	11	12	30
47	12	13	31



1	073170036
1	073170037
1	073170038
1	073170039
1	073170040
1	073170041
1	073170042
1	073170043
1	073170044
1	073170045
1	073170046
1	073170047



CE

EN 20345 S1

7318AK

scarpe "light" in pelle scamosciata traforata, suola racing



EU	UK	USA	J
36	3,5	4	22,5
37	4,5	5	23
38	5	6	24
39	6	7	24,5
40	6,5	7,5	25,5
41	7	8,5	26,5
42	8	9	27
43	9	10	28
44	10	10,5	28,5
45	10,5	11,5	29,5
46	11	12	30
47	12	13	31



1	073180036
1	073180037
1	073180038
1	073180039
1	073180040
1	073180041
1	073180042
1	073180043
1	073180044
1	073180045
1	073180046
1	073180047



CE

EN 20345 S1

7319AK

scarpe "light" in pelle pieno fiore bottalata, suola racing



EU	UK	USA	J
36	3,5	4	22,5
37	4,5	5	23
38	5	6	24
39	6	7	24,5
40	6,5	7,5	25,5
41	7	8,5	26,5
42	8	9	27
43	9	10	28
44	10	10,5	28,5
45	10,5	11,5	29,5
46	11	12	30
47	12	13	31



1	073190036
1	073190037
1	073190038
1	073190039
1	073190040
1	073190041
1	073190042
1	073190043
1	073190044
1	073190045
1	073190046
1	073190047



CE

EN 20345 S2

7326NKK

scarpe alte waterproof in pelle con membrana termosaldata idrorepellente e suola in gomma ad alta resistenza



EU	UK	USA	J
39	6	7	24,5
40	6,5	7,5	25,5
41	7	8,5	26,5
42	8	9	27
43	9	10	28
44	10	10,5	28,5
45	10,5	11,5	29,5
46	11	12	30
47	12	13	31



1	073260039
1	073260040
1	073260041
1	073260042
1	073260043
1	073260044
1	073260045
1	073260046
1	073260047



CE

EN 20345 S3 HRO

7327NKK

stivali "POLAR" in pelle pieno fiore idrorepellente, con scarpetta estraibile



EU	UK	USA	J		
39	6	7	24,5	1	073270039
40	6,5	7,5	25,5	1	073270040
41	7	8,5	26,5	1	073270041
42	8	9	27	1	073270042
43	9	10	28	1	073270043
44	10	10,5	28,5	1	073270044
45	10,5	11,5	29,5	1	073270045
46	11	12	30	1	073270046



CE

EN 20345 S3 HRO

7327R

scarpette interne per stivali 7327NKK



EU	UK	USA	J		
39	6	7	24,5	1	073270939
40	6,5	7,5	25,5	1	073270940
41	7	8,5	26,5	1	073270941
42	8	9	27	1	073270942
43	9	10	28	1	073270943
44	10	10,5	28,5	1	073270944
45	10,5	11,5	29,5	1	073270945
46	11	12	30	1	073270946



7328

stivali di sicurezza "alta visibilità"



EU	UK	USA	J		
38	5	6	24	1	073280038
39	6	7	24,5	1	073280039
40	6,5	7,5	25,5	1	073280040
41	7	8,5	26,5	1	073280041
42	8	9	27	1	073280042
43	9	10	28	1	073280043
44	10	10,5	28,5	1	073280044
45	10,5	11,5	29,5	1	073280045
46	11	12	30	1	073280046
47	12	13	31	1	073280047



CE

EN 20345 S5

7328B

stivali di sicurezza



EU	UK	USA	J		
38	5	6	24	1	073280138
39	6	7	24,5	1	073280139
40	6,5	7,5	25,5	1	073280140
41	7	8,5	26,5	1	073280141
42	8	9	27	1	073280142
43	9	10	28	1	073280143
44	10	10,5	28,5	1	073280144
45	10,5	11,5	29,5	1	073280145
46	11	12	30	1	073280146
47	12	13	31	1	073280147



CE

EN 20345 S4

7328N

stivali di sicurezza



EU	UK	USA	J
38	5	6	24
39	6	7	24,5
40	6,5	7,5	25,5
41	7	8,5	26,5
42	8	9	27
43	9	10	28
44	10	10,5	28,5
45	10,5	11,5	29,5
46	11	12	30
47	12	13	31



1	073280238
1	073280239
1	073280240
1	073280241
1	073280242
1	073280243
1	073280244
1	073280245
1	073280246
1	073280247



CE



EN 20345 S5



7329TKK

stivali sfoderati
in Nabuk ingrassato



EU	UK	USA	J
38	5	6	24
39	6	7	24,5
40	6,5	7,5	25,5
41	7	8,5	26,5
42	8	9	27
43	9	10	28
44	10	10,5	28,5
45	10,5	11,5	29,5
46	11	12	30
47	12	13	31
48	13	14	32



1	073290338
1	073290339
1	073290340
1	073290341
1	073290342
1	073290343
1	073290344
1	073290345
1	073290346
1	073290347
1	073290348



CE



EN 20345 S3



7330TKK

stivali in Nabuk ingrassato,
foderati in sintetico



EU	UK	USA	J
38	5	6	24
39	6	7	24,5
40	6,5	7,5	25,5
41	7	8,5	26,5
42	8	9	27
43	9	10	28
44	10	10,5	28,5
45	10,5	11,5	29,5
46	11	12	30
47	12	13	31
48	13	14	32



1	073300338
1	073300339
1	073300340
1	073300341
1	073300342
1	073300343
1	073300344
1	073300345
1	073300346
1	073300347
1	073300348

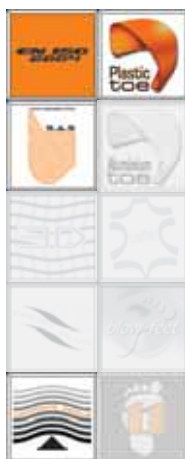

CE



EN 20345 S3



7333NKK

sandali "METAL FREE"
in morbida pelle scamosciata



EU	UK	USA	J
35	2,5	3	22
36	3,5	4	22,5
37	4,5	5	23
38	5	6	24
39	6	7	24,5
40	6,5	7,5	25,5
41	7	8,5	26,5
42	8	9	27
43	9	10	28
44	10	10,5	28,5
45	10,5	11,5	29,5
46	11	12	30
47	12	13	31



1	073330035
1	073330036
1	073330037
1	073330038
1	073330039
1	073330040
1	073330041
1	073330042
1	073330043
1	073330044
1	073330045
1	073330046
1	073330047



CE



EN 20345 S1P



7334NKK

mocassini "METAL FREE"
in morbida pelle scamosciata



EU	UK	USA	J		
35	2,5	3	22	1	073340035
36	3,5	4	22,5	1	073340036
37	4,5	5	23	1	073340037
38	5	6	24	1	073340038
39	6	7	24,5	1	073340039
40	6,5	7,5	25,5	1	073340040
41	7	8,5	26,5	1	073340041
42	8	9	27	1	073340042
43	9	10	28	1	073340043
44	10	10,5	28,5	1	073340044
45	10,5	11,5	29,5	1	073340045
46	11	12	30	1	073340046
47	12	13	31	1	073340047



CE

EN 20345 S1P

7335NKK

scarpe in morbida pelle scamosciata
con inserti in nylon



EU	UK	USA	J		
38	5	6	24	1	073350038
39	6	7	24,5	1	073350039
40	6,5	7,5	25,5	1	073350040
41	7	8,5	26,5	1	073350041
42	8	9	27	1	073350042
43	9	10	28	1	073350043
44	10	10,5	28,5	1	073350044
45	10,5	11,5	29,5	1	073350045
46	11	12	30	1	073350046
47	12	13	31	1	073350047



CE

EN 20345 S1P

7336NKK

scarpe alte in morbida pelle scamosciata
con inserti in nylon



EU	UK	USA	J		
38	5	6	24	1	073360038
39	6	7	24,5	1	073360039
40	6,5	7,5	25,5	1	073360040
41	7	8,5	26,5	1	073360041
42	8	9	27	1	073360042
43	9	10	28	1	073360043
44	10	10,5	28,5	1	073360044
45	10,5	11,5	29,5	1	073360045
46	11	12	30	1	073360046
47	12	13	31	1	073360047



CE

EN 20345 S1P

7340R

scarpe in pelle scamosciata
senza puntale e lamina antiperforazione
con suola in gomma



EU	UK	USA	J		
38	5	6	24	1	073400038
39	6	7	24,5	1	073400039
40	6,5	7,5	25,5	1	073400040
41	7	8,5	26,5	1	073400041
42	8	9	27	1	073400042
43	9	10	28	1	073400043
44	10	10,5	28,5	1	073400044
45	10,5	11,5	29,5	1	073400045
46	11	12	30	1	073400046
47	12	13	31	1	073400047



CE

EN 20347 O1 HRO-FO

7341R

scarpe alte in pelle scamosciata
senza puntale e lamina antiperforazione
con suola in gomma



EU	UK	USA	J	
38	5	6	24	1 073410038
39	6	7	24,5	1 073410039
40	6,5	7,5	25,5	1 073410040
41	7	8,5	26,5	1 073410041
42	8	9	27	1 073410042
43	9	10	28	1 073410043
44	10	10,5	28,5	1 073410044
45	10,5	11,5	29,5	1 073410045
46	11	12	30	1 073410046
47	12	13	31	1 073410047



CE



EN 20347 O1 HRO-FO



7342RKK

scarpe in pelle scamosciata
con suola in gomma



EU	UK	USA	J	
38	5	6	24	1 073420038
39	6	7	24,5	1 073420039
40	6,5	7,5	25,5	1 073420040
41	7	8,5	26,5	1 073420041
42	8	9	27	1 073420042
43	9	10	28	1 073420043
44	10	10,5	28,5	1 073420044
45	10,5	11,5	29,5	1 073420045
46	11	12	30	1 073420046
47	12	13	31	1 073420047



CE



EN 20345 S1P HRO



7342RKK/G

scarpe in pelle scamosciata
con suola in gomma



EU	UK	USA	J	
38	5	6	24	1 073420138
39	6	7	24,5	1 073420139
40	6,5	7,5	25,5	1 073420140
41	7	8,5	26,5	1 073420141
42	8	9	27	1 073420142
43	9	10	28	1 073420143
44	10	10,5	28,5	1 073420144
45	10,5	11,5	29,5	1 073420145
46	11	12	30	1 073420146
47	12	13	31	1 073420147



CE



EN 20345 S1P HRO



7343RKK

scarpe alte in pelle scamosciata
con suola in gomma



EU	UK	USA	J	
38	5	6	24	1 073430038
39	6	7	24,5	1 073430039
40	6,5	7,5	25,5	1 073430040
41	7	8,5	26,5	1 073430041
42	8	9	27	1 073430042
43	9	10	28	1 073430043
44	10	10,5	28,5	1 073430044
45	10,5	11,5	29,5	1 073430045
46	11	12	30	1 073430046
47	12	13	31	1 073430047



CE



EN 20345 S1P HRO

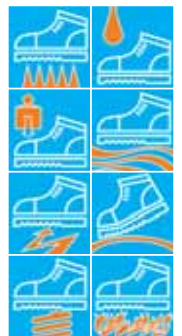

7343RKK/G

scarpe alte in pelle scamosciata
con suola in gomma



EU	UK	USA	J		
38	5	6	24	1	073430138
39	6	7	24,5	1	073430139
40	6,5	7,5	25,5	1	073430140
41	7	8,5	26,5	1	073430141
42	8	9	27	1	073430142
43	9	10	28	1	073430143
44	10	10,5	28,5	1	073430144
45	10,5	11,5	29,5	1	073430145
46	11	12	30	1	073430146
47	12	13	31	1	073430147



CE

EN 20345 S1P HRO

7344RKK

scarpe in pelle nabuk idrorepellente
con suola in gomma



EU	UK	USA	J		
38	5	6	24	1	073440038
39	6	7	24,5	1	073440039
40	6,5	7,5	25,5	1	073440040
41	7	8,5	26,5	1	073440041
42	8	9	27	1	073440042
43	9	10	28	1	073440043
44	10	10,5	28,5	1	073440044
45	10,5	11,5	29,5	1	073440045
46	11	12	30	1	073440046
47	12	13	31	1	073440047



CE

EN 20345 S3 HRO

7345RKK

scarpe alte in pelle nabuk idrorepellente
con suola in gomma



EU	UK	USA	J		
38	5	6	24	1	073450038
39	6	7	24,5	1	073450039
40	6,5	7,5	25,5	1	073450040
41	7	8,5	26,5	1	073450041
42	8	9	27	1	073450042
43	9	10	28	1	073450043
44	10	10,5	28,5	1	073450044
45	10,5	11,5	29,5	1	073450045
46	11	12	30	1	073450046
47	12	13	31	1	073450047



CE

EN 20345 S3 HRO

7346RKK

mocassino in pelle scamosciata con inserti in mesh,
chiusura a strappo e suola in gomma



EU	UK	USA	J		
38	5	6	24	1	073460038
39	6	7	24,5	1	073460039
40	6,5	7,5	25,5	1	073460040
41	7	8,5	26,5	1	073460041
42	8	9	27	1	073460042
43	9	10	28	1	073460043
44	10	10,5	28,5	1	073460044
45	10,5	11,5	29,5	1	073460045
46	11	12	30	1	073460046
47	12	13	31	1	073460047



CE

EN 20345 S1P HRO

7347RKK

scarpe in pelle scamosciata traforata con suola in gomma



EU	UK	USA	J
38	5	6	24
39	6	7	24,5
40	6,5	7,5	25,5
41	7	8,5	26,5
42	8	9	27
43	9	10	28
44	10	10,5	28,5
45	10,5	11,5	29,5
46	11	12	30
47	12	13	31



1	073470038
1	073470039
1	073470040
1	073470041
1	073470042
1	073470043
1	073470044
1	073470045
1	073470046
1	073470047



CE

EN 20345 S1P HRO

7348RKK

scarpe in pelle scamosciata con inserti in mesh e suola in gomma



EU	UK	USA	J
38	5	6	24
39	6	7	24,5
40	6,5	7,5	25,5
41	7	8,5	26,5
42	8	9	27
43	9	10	28
44	10	10,5	28,5
45	10,5	11,5	29,5
46	11	12	30
47	12	13	31



1	073480038
1	073480039
1	073480040
1	073480041
1	073480042
1	073480043
1	073480044
1	073480045
1	073480046
1	073480047



CE

EN 20345 S1P HRO

7349RKK

scarpe in pelle pieno fiore con suola in gomma



EU	UK	USA	J
38	5	6	24
39	6	7	24,5
40	6,5	7,5	25,5
41	7	8,5	26,5
42	8	9	27
43	9	10	28
44	10	10,5	28,5
45	10,5	11,5	29,5
46	11	12	30
47	12	13	31



1	073490038
1	073490039
1	073490040
1	073490041
1	073490042
1	073490043
1	073490044
1	073490045
1	073490046
1	073490047



CE

EN 20345 S3 HRO

7350RKK

scarpe alte in pelle pieno fiore con suola in gomma



EU	UK	USA	J
38	5	6	24
39	6	7	24,5
40	6,5	7,5	25,5
41	7	8,5	26,5
42	8	9	27
43	9	10	28
44	10	10,5	28,5
45	10,5	11,5	29,5
46	11	12	30
47	12	13	31



1	073500038
1	073500039
1	073500040
1	073500041
1	073500042
1	073500043
1	073500044
1	073500045
1	073500046
1	073500047



CE

EN 20345 S3 HRO

7384Bscarpe outdoor jogging in nylon mesh
con inserti in PU

EU	UK	USA	J		
36	3,5	4	22,5	1	073840236
37	4,5	5	23	1	073840237
38	5	6	24	1	073840238
39	6	7	24,5	1	073840239
40	6,5	7,5	25,5	1	073840240
41	7	8,5	26,5	1	073840241
42	8	9	27	1	073840242
43	9	10	28	1	073840243
44	10	10,5	28,5	1	073840244
45	10,5	11,5	29,5	1	073840245
46	11	12	30	1	073840246

**7385A**scarpe outdoor jogging in nylon mesh
con inserti in PU

EU	UK	USA	J		
36	3,5	4	22,5	1	073850136
37	4,5	5	23	1	073850137
38	5	6	24	1	073850138
39	6	7	24,5	1	073850139
41	7	8,5	26,5	1	073850141
42	8	9	27	1	073850142
43	9	10	28	1	073850143
44	10	10,5	28,5	1	073850144

**7385B**scarpe outdoor jogging in nylon mesh
con inserti in PU

EU	UK	USA	J		
36	3,5	4	22,5	1	073850236
37	4,5	5	23	1	073850237
38	5	6	24	1	073850238
39	6	7	24,5	1	073850239
40	6,5	7,5	25,5	1	073850240
41	7	8,5	26,5	1	073850241
42	8	9	27	1	073850242
43	9	10	28	1	073850243
44	10	10,5	28,5	1	073850244
45	10,5	11,5	29,5	1	073850245
46	11	12	30	1	073850246

**7387B**scarpe outdoor jogging in nylon mesh
con inserti in PU

EU	UK	USA	J		
36	3,5	4	22,5	1	073870236
37	4,5	5	23	1	073870237
38	5	6	24	1	073870238
39	6	7	24,5	1	073870239
40	6,5	7,5	25,5	1	073870240
41	7	8,5	26,5	1	073870241
42	8	9	27	1	073870242
43	9	10	28	1	073870243
44	10	10,5	28,5	1	073870244
45	10,5	11,5	29,5	1	073870245
46	11	12	30	1	073870246



7388B

scarpe outdoor jogging in nylon mesh
con inserti in PU



EU	UK	USA	J		
36	3,5	4	22,5		1 073880236
37	4,5	5	23		1 073880237
38	5	6	24		1 073880238
39	6	7	24,5		1 073880239
40	6,5	7,5	25,5		1 073880240
41	7	8,5	26,5		1 073880241
42	8	9	27		1 073880242
43	9	10	28		1 073880243
44	10	10,5	28,5		1 073880244
45	10,5	11,5	29,5		1 073880245
46	11	12	30		1 073880246



7390

scarpe outdoor "raid" impermeabilizzate
in pelle scamosciata con inserti in nylon mesh, suola in EVA e
gomma



EU	UK	USA	J		
39	6	7	24,5		1 073900039
40	6,5	7,5	25,5		1 073900040
41	7	8,5	26,5		1 073900041
42	8	9	27		1 073900042
43	9	10	28		1 073900043
44	10	10,5	28,5		1 073900044
45	10,5	11,5	29,5		1 073900045
46	11	12	30		1 073900046



7390A

scarpe outdoor "raid" in nylon mesh
con inserti in PU



EU	UK	USA	J		
36	3,5	4	22,5		1 073900136
37	4,5	5	23		1 073900137
38	5	6	24		1 073900138
39	6	7	24,5		1 073900139
40	6,5	7,5	25,5		1 073900140
41	7	8,5	26,5		1 073900141
42	8	9	27		1 073900142
43	9	10	28		1 073900143
44	10	10,5	28,5		1 073900144
45	10,5	11,5	29,5		1 073900145
46	11	12	30		1 073900146



7391

scarpe outdoor "raid" in Nabuk e pelle scamosciata, suola in
EVA e gomma



EU	UK	USA	J		
39	6	7	24,5		1 073910039
40	6,5	7,5	25,5		1 073910040
41	7	8,5	26,5		1 073910041
42	8	9	27		1 073910042
43	9	10	28		1 073910043
44	10	10,5	28,5		1 073910044
45	10,5	11,5	29,5		1 073910045



7392A

scarpe outdoor "raid" in pelle scamosciata con inserti in nylon mesh



EU	UK	USA	J		
36	3,5	4	22,5		1 073920136
37	4,5	5	23		1 073920137
38	5	6	24		1 073920138
39	6	7	24,5		1 073920139
40	6,5	7,5	25,5		1 073920140
41	7	8,5	26,5		1 073920141
42	8	9	27		1 073920142
43	9	10	28		1 073920143
44	10	10,5	28,5		1 073920144
45	10,5	11,5	29,5		1 073920145
46	11	12	30		1 073920146



7393

scarpe outdoor "trekking" in pelle scamosciata ed inserti in nylon mesh, suola in EVA e gomma



EU	UK	USA	J		
38	5	6	24		1 073930038
39	6	7	24,5		1 073930039
40	6,5	7,5	25,5		1 073930040
41	7	8,5	26,5		1 073930041
42	8	9	27		1 073930042
43	9	10	28		1 073930043
44	10	10,5	28,5		1 073930044
45	10,5	11,5	29,5		1 073930045
46	11	12	30		1 073930046
47	12	13	31		1 073930047



7395

scarpe outdoor "trekking" impermeabilizzate in pelle scamosciata, suola in EVA e gomma



EU	UK	USA	J		
40	6,5	7,5	25,5		1 073950040
41	7	8,5	26,5		1 073950041
42	8	9	27		1 073950042
43	9	10	28		1 073950043
44	10	10,5	28,5		1 073950044
45	10,5	11,5	29,5		1 073950045
46	11	12	30		1 073950046



7396

scarpe outdoor "trekking" impermeabilizzate in pelle scamosciata con inserti in nylon mesh, suola in poliuretano bidensità



EU	UK	USA	J		
39	6	7	24,5		1 073960039
40	6,5	7,5	25,5		1 073960040
41	7	8,5	26,5		1 073960041
42	8	9	27		1 073960042
43	9	10	28		1 073960043
44	10	10,5	28,5		1 073960044
45	10,5	11,5	29,5		1 073960045
46	11	12	30		1 073960046
47	12	13	31		1 073960047





7398 TNT

sottopiedi intercambiabili in CARBON



EU	UK	USA	J		
35	2,5	3	22	1	073980035
36	3,5	4	22,5	1	073980036
37	4,5	5	23	1	073980037
38	5	6	24	1	073980038
39	6	7	24,5	1	073980039
40	6,5	7,5	25,5	1	073980040
41	7	8,5	26,5	1	073980041
42	8	9	27	1	073980042
43	9	10	28	1	073980043
44	10	10,5	28,5	1	073980044
45	10,5	11,5	29,5	1	073980045
46	11	12	30	1	073980046
47	12	13	31	1	073980047
48	13	14	32	1	073980048

7398BF

sottopiedi anatomici "BLOW-FEET"



EU	UK	USA	J		
36	3,5	4	22,5	1	073980336
37	4,5	5	23	1	073980337
38	5	6	24	1	073980338
39	6	7	24,5	1	073980339
40	6,5	7,5	25,5	1	073980340
41	7	8,5	26,5	1	073980341
42	8	9	27	1	073980342
43	9	10	28	1	073980343
44	10	10,5	28,5	1	073980344
45	10,5	11,5	29,5	1	073980345
46	11	12	30	1	073980346
47	12	13	31	1	073980347
48	13	14	32	1	073980348

7398 A/M

sottopiedi anatomici in EVA microforati



EU	UK	USA	J		
35	2,5	3	22	1	073980135
36	3,5	4	22,5	1	073980136
37	4,5	5	23	1	073980137
38	5	6	24	1	073980138
39	6	7	24,5	1	073980139
40	6,5	7,5	25,5	1	073980140
41	7	8,5	26,5	1	073980141
42	8	9	27	1	073980142
43	9	10	28	1	073980143
44	10	10,5	28,5	1	073980144
45	10,5	11,5	29,5	1	073980145
46	11	12	30	1	073980146
47	12	13	31	1	073980147
48	13	14	32	1	073980148

7398FT

sottopiedi anatomici fusstatic



EU	UK	USA	J		
36	3,5	4	22,5	1	073980736
37	4,5	5	23	1	073980737
38	5	6	24	1	073980738
39	6	7	24,5	1	073980739
40	6,5	7,5	25,5	1	073980740
41	7	8,5	26,5	1	073980741
42	8	9	27	1	073980742
43	9	10	28	1	073980743
44	10	10,5	28,5	1	073980744
45	10,5	11,5	29,5	1	073980745
46	11	12	30	1	073980746
47	12	13	31	1	073980747
48	13	14	32	1	073980748

7398C

sottopiedi in cuoio



EU	UK	USA	J		
36	3,5	4	22,5	1	073980436
37	4,5	5	23	1	073980437
38	5	6	24	1	073980438
39	6	7	24,5	1	073980439
40	6,5	7,5	25,5	1	073980440
41	7	8,5	26,5	1	073980441
42	8	9	27	1	073980442
43	9	10	28	1	073980443
44	10	10,5	28,5	1	073980444
45	10,5	11,5	29,5	1	073980445
46	11	12	30	1	073980446
47	12	13	31	1	073980447
48	13	14	32	1	073980448

7398ESD

sottopiedi anatomici per calzature certificate ESD



EU	UK	USA	J		
36	3,5	4	22,5	1	073980636
37	4,5	5	23	1	073980637
38	5	6	24	1	073980638
39	6	7	24,5	1	073980639
40	6,5	7,5	25,5	1	073980640
41	7	8,5	26,5	1	073980641
42	8	9	27	1	073980642
43	9	10	28	1	073980643
44	10	10,5	28,5	1	073980644
45	10,5	11,5	29,5	1	073980645
46	11	12	30	1	073980646
47	12	13	31	1	073980647

7399 G/N

confezione 10 paia di stringhe, cm 90



	cm		
7399 G/N	90	1	073990009

I prezzi indicati sono relativi a 10 paia

7399 A/N...

confezione 10 paia di stringhe



	cm		
7399 A/N100	100	1	073990010
7399 A/N120	120	1	073990012

I prezzi indicati sono relativi a 10 paia

7399M...

confezione 10 paia di stringhe marroni



	cm		
7399M 90	90	1	073990013
7399M 120	120	1	073990014

I prezzi indicati sono relativi a 10 paia

7399B...

confezione 10 paia di stringhe beige



	cm		
7399B 90	90	1	073990015
7399B 120	120	1	073990016

I prezzi indicati sono relativi a 10 paia

7411

calzini "pesanti" in Outlast® e spugna



	EU		
S	37-39	1	074110001
M	40-42	1	074110002
L	43-45	1	074110003
XL	46-48	1	074110004

7398AL

sottopiedi per basse temperature in feltro alluminizzato



EU	UK	USA	J		
38	5	6	24	1	073980538
39	6	7	24,5	1	073980539
40	6,5	7,5	25,5	1	073980540
41	7	8,5	26,5	1	073980541
42	8	9	27	1	073980542
43	9	10	28	1	073980543
44	10	10,5	28,5	1	073980544
45	10,5	11,5	29,5	1	073980545
46	11	12	30	1	073980546
47	12	13	31	1	073980547
48	13	14	32	1	073980548



7412

calze "pesanti" in Outlast® e spugna



	EU		
S	37-39	1	074120001
M	40-42	1	074120002
L	43-45	1	074120003
XL	46-48	1	074120004

7413calzini in spugna e poliammide.
calzata destra e sinistra

	EU		
S	37-39	1	074130001
M	40-42	1	074130002
L	43-45	1	074130003
XL	46-48	1	074130004

7414calze in spugna e poliammide.
calzata destra e sinistra

	EU		
S	37-39	1	074140001
M	40-42	1	074140002
L	43-45	1	074140003
XL	46-48	1	074140004

7415

calzini in Coolmax® e Dryarn®



	EU		
S	37-39	1	074150001
M	40-42	1	074150002
L	43-45	1	074150003
XL	46-48	1	074150004

7416

calze in Coolmax® e Dryarn®



	EU		
S	37-39	1	074160001
M	40-42	1	074160002
L	43-45	1	074160003
XL	46-48	1	074160004

7417

calzini in Tactel®



	EU		
S	37-39	1	074170001
M	40-42	1	074170002
L	43-45	1	074170003
XL	46-48	1	074170004

7418

calzini in Meryl Skinlife® antibatterico



	EU		
S	37-39	1	074180001
M	40-42	1	074180002
L	43-45	1	074180003
XL	46-48	1	074180004

Beta

Collection



Freestyle

Freestyle
sport

Classic



Racing



Work

Sales
support

Junior

Golf
collection

Guida alla lettura

Beta Workwear è il nuovo progetto che Beta Utensili sviluppa avvicinandosi ulteriormente alle esigenze della propria clientela.

Alla vasta gamma di utensili e di calzature di sicurezza, viene oggi affiancata la nuova linea di articoli di abbigliamento dedicati alla

protezione ed al comfort del professionista, spesso obbligato ad operare nelle condizioni più critiche.

Capi "alla moda" confezionati con materiali di alta qualità, disegnati analizzando le esigenze pratiche degli utilizzatori.

numero articolo

7899

gilet tecnico da lavoro
in T/C Canvas 270 g, grigio



taglia

M
XL

1 078990002
1 078990004

prezzo unitario

numero codice

numero pezzi nella confezione



	I	F	D	E	UK	USA
XS	46	38	42	40	30	32
S	48	40	44	42	32	34
M	50	42	46	44	34	36
L	52	44	48	46	36	38
XL	54	46	50	48	38	40
XXL	56	48	52	50	40	42
XXXL	58	50	54	52	42	44



7500

pantaloni leggeri 5 tasche
in twill di cotone 225 g, sabbia



XS	1 075000046
S	1 075000048
M	1 075000050
L	1 075000052
XL	1 075000054
XXL	1 075000056

7510

pantaloni multitasche
in T/C barrato 260 g, sabbia



XS	1 075100046
S	1 075100048
M	1 075100050
L	1 075100052
XL	1 075100054
XXL	1 075100056

7511

bermuda multitasche
in T/C barrato 260 g, sabbia



XS	1 075110046
S	1 075110048
M	1 075110050
L	1 075110052
XL	1 075110054
XXL	1 075110056

7511

bermuda multitasche
in T/C barrato 260 g, blu



M	1 075110150
L	1 075110152
XL	1 075110154

7511

bermuda multitasche
in T/C barrato 260 g, grigio



XS	1 075110246
S	1 075110248
M	1 075110250
L	1 075110252
XL	1 075110254
XXL	1 075110256

7500

pantaloni leggeri 5 tasche
in twill di cotone 225 g, nero



XS	1 075000146
S	1 075000148
M	1 075000150
L	1 075000152
XL	1 075000154
XXL	1 075000156

7510

pantaloni multitasche
in T/C barrato 260 g, grigio



M	1 075100250
L	1 075100252
XL	1 075100254

7512

pantaloni multitasche
in canvas 100% cotone 240 g, sabbia



XS	1	075120046
S	1	075120048
M	1	075120050
L	1	075120052
XL	1	075120054
XXL	1	075120056
XXXL	1	075120058

7512

pantaloni multitasche
in canvas 100% cotone 240 g, blu



XS	1	075120146
S	1	075120148
M	1	075120150
L	1	075120152
XL	1	075120154
XXL	1	075120156
XXXL	1	075120158

**7512**

pantaloni multitasche
in canvas 100% cotone 240 g, verde



XS	1	075120346
S	1	075120348
M	1	075120350
L	1	075120352
XL	1	075120354
XXL	1	075120356
XXXL	1	075120358

7513

bermuda multitasche
in canvas 100% cotone 240 g, sabbia



XS	1	075130046
S	1	075130048
M	1	075130050
L	1	075130052
XL	1	075130054
XXL	1	075130056
XXXL	1	075130058

7513

bermuda multitasche
in canvas 100% cotone 240 g, blu



XS	1	075130146
S	1	075130148
M	1	075130150
L	1	075130152
XL	1	075130154
XXL	1	075130156
XXXL	1	075130158

7513

bermuda multitasche
in canvas 100% cotone 240 g, verde



XS	1	075130346
S	1	075130348
M	1	075130350
L	1	075130352
XL	1	075130354
XXL	1	075130356
XXXL	1	075130358





7521

pantaloni jeans 5 tasche
in cotone denim 100% 10 once, blu



XS	1	075210046
S	1	075210048
M	1	075210050
L	1	075210052
XL	1	075210054
XXL	1	075210056

7530

camicia jeans
in cotone denim 100% 6 once, blu



S	1	075300001
M	1	075300002
L	1	075300003
XL	1	075300004
XXL	1	075300005

7531

camicia jeans, mezze maniche
in cotone denim 100% 6 once, blu



S	1	075310001
M	1	075310002
L	1	075310003
XL	1	075310004
XXL	1	075310005

7540

camicia leggera
in twill di cotone 100% 145 g, sabbia



S	1	075400001
M	1	075400002
L	1	075400003
XL	1	075400004
XXL	1	075400005

7540

camicia leggera
in twill di cotone 100% 145 g, blu



S	1	075400101
M	1	075400102
L	1	075400103
XL	1	075400104
XXL	1	075400105

7541

camicia leggera, mezze maniche
in twill di cotone 100% 145 g, sabbia



S	1	075410001
M	1	075410002
L	1	075410003
XL	1	075410004
XXL	1	075410005

7541

camicia leggera, mezze maniche
in twill di cotone 100% 145 g, blu



S	1	075410101
M	1	075410102
L	1	075410103
XL	1	075410104
XXL	1	075410105

7545

camicia boscaiolo
in flanella di T/C 200 g, arancio



S	1	075450001
L	1	075450003
XL	1	075450004
XXL	1	075450005

7550

polo 3 bottoni in cotone
piquè cardato 220 g, bianco



S	2	075500001
M	2	075500002
L	2	075500003
XL	2	075500004
XXL	2	075500005

7550

polo 3 bottoni in cotone
piquè cardato 220 g, grigio



S	2	075500101
M	2	075500102
L	2	075500103
XL	2	075500104
XXL	2	075500105

7550

polo 3 bottoni in cotone
piquè cardato 220 g, nero



S	2	075500201
M	2	075500202
L	2	075500203
XL	2	075500204
XXL	2	075500205

7550

polo 3 bottoni in cotone
piquè cardato 220 g, arancio



S	2	075500301
M	2	075500302
L	2	075500303
XL	2	075500304
XXL	2	075500305

7552

polo tecnica
in ho-cooling® 190 g, sabbia



S	2	075520001
M	2	075520002
L	2	075520003
XL	2	075520004
XXL	2	075520005

7552

polo tecnica
in ho-cooling® 190 g, blu



S	2	075520101
M	2	075520102
L	2	075520103
XL	2	075520104
XXL	2	075520105

7554

polo 3 bottoni manica lunga
in cotone piquè cardato 220 g, bianco



S	2	075540001
M	2	075540002
L	2	075540003
XL	2	075540004
XXL	2	075540005

7554

polo 3 bottoni manica lunga
in cotone piquè cardato 220 g, grigio



S	2	075540101
M	2	075540102
L	2	075540103
XL	2	075540104
XXL	2	075540105

7554

polo 3 bottoni manica lunga
in cotone piquè cardato 220 g, nero



S	2	075540201
M	2	075540202
L	2	075540203
XL	2	075540204
XXL	2	075540205

7554

polo 3 bottoni manica lunga
in cotone piquè cardato 220 g, arancio



S	2	075540301
M	2	075540302
L	2	075540303
XL	2	075540304
XXL	2	075540305

7553

t-shirt work in 100% cotone 145 g,
arancio



XS	5	075530000
S	5	075530001
M	5	075530002
L	5	075530003
XL	5	075530004
XXL	5	075530005
XXXL	5	075530006

7553

t-shirt work in 100% cotone 145 g,
grigio



XS	5	075530100
S	5	075530101
M	5	075530102
L	5	075530103
XL	5	075530104
XXL	5	075530105
XXXL	5	075530106

7553

t-shirt work in 100% cotone 145 g,
nero



XS	5	075530200
S	5	075530201
M	5	075530202
L	5	075530203
XL	5	075530204
XXL	5	075530205
XXXL	5	075530206

7553D

t-shirt work in 100% cotone 145 g,
stampa piccola posteriore, arancio



XS	5	075530020
S	5	075530021
M	5	075530022
L	5	075530023
XL	5	075530024
XXL	5	075530025
XXXL	5	075530026

7553D

t-shirt work in 100% cotone 145 g,
stampa piccola posteriore, grigio



XS	5	075530120
S	5	075530121
M	5	075530122
L	5	075530123
XL	5	075530124
XXL	5	075530125
XXXL	5	075530126

7553D

t-shirt work in 100% cotone 145 g,
stampa piccola posteriore, nero



Dimensione	Quantità	Articolo
XS	5	075530220
S	5	075530221
M	5	075530222
L	5	075530223
XL	5	075530224
XXL	5	075530225
XXXL	5	075530226

7555

gilet multitasche leggero
in twill T/C 180 g, grigio



Dimensione	Quantità	Articolo
S	1	075550201
M	1	075550202
L	1	075550203
XL	1	075550204
XXL	1	075550205

7566

gilet multitasche
in canvas 100% cotone 240 g, blu



Dimensione	Quantità	Articolo
S	1	075660101
M	1	075660102
L	1	075660103
XL	1	075660104
XXL	1	075660105
XXXL	1	075660106

7555

gilet multitasche leggero
in twill T/C 180 g, sabbia



Dimensione	Quantità	Articolo
S	1	075550001
M	1	075550002
L	1	075550003
XL	1	075550004
XXL	1	075550005

7565

gilet multitasche pesante
in T/C barrato 260 g, sabbia



Dimensione	Quantità	Articolo
S	1	075650001
M	1	075650002
L	1	075650003
XL	1	075650004
XXL	1	075650005

7566

gilet multitasche
in canvas 100% cotone 240 g, verde



Dimensione	Quantità	Articolo
S	1	075660301
M	1	075660302
L	1	075660303
XL	1	075660304
XXL	1	075660305
XXXL	1	075660306

7555

gilet multitasche leggero
in twill T/C 180 g, blu



Dimensione	Quantità	Articolo
S	1	075550101
M	1	075550102
L	1	075550103
XL	1	075550104
XXL	1	075550105

7566

gilet multitasche
in canvas 100% cotone 240 g, sabbia



Dimensione	Quantità	Articolo
S	1	075660001
M	1	075660002
L	1	075660003
XL	1	075660004
XXL	1	075660005
XXXL	1	075660006

7575

gilet in ripstop impermeabilizzato 200 g
imbottito e foderato, sabbia



Dimensione	Quantità	Articolo
S	1	075750001
M	1	075750002
L	1	075750003
XL	1	075750004
XXL	1	075750005

7575A

gilet in ripstop impermeabilizzato 200 g
imbottito e foderato, nero



XS	1	075750200
S	1	075750201
M	1	075750202
L	1	075750203
XL	1	075750204
XXL	1	075750205
XXXL	1	075750206

7576

gilet in "Taslon", imbottito e foderato, blu



XS	1	075760000
S	1	075760001
M	1	075760002
L	1	075760003
XL	1	075760004
XXL	1	075760005
XXXL	1	075760006

7576

gilet in "Taslon", imbottito e foderato, marrone



XS	1	075760100
S	1	075760101
M	1	075760102
L	1	075760103
XL	1	075760104
XXL	1	075760105
XXXL	1	075760106

7576

gilet in "Taslon", imbottito e foderato, verde



XS	1	075760200
S	1	075760201
M	1	075760202
L	1	075760203
XL	1	075760204
XXL	1	075760205
XXXL	1	075760206

7585

gilet in "Oxford" impermeabilizzato 180 g
imbottito e foderato, sabbia/grigio



S	1	075850001
M	1	075850002
L	1	075850003
XL	1	075850004
XXL	1	075850005

7595

gilet in nylon "Taslon" impermeabilizzato 120 g
interno in pile, sabbia



S	1	075950001
M	1	075950002
L	1	075950003
XL	1	075950004
XXL	1	075950005

7595

gilet in nylon "Taslon" impermeabilizzato 120 g
interno in pile, blu



S	1	075950101
M	1	075950102
L	1	075950103
XL	1	075950104
XXL	1	075950105

7615

gilet in pile bilaminato 370 g,
sabbia



S	1	076150001
M	1	076150002
L	1	076150003
XL	1	076150004
XXL	1	076150005

7615

gilet in pile bilaminato 370 g,
grigio



S	1	076150101
M	1	076150102
L	1	076150103
XL	1	076150104
XXL	1	076150105

7620

giaccone in pile 250 g
imbottito e foderato, sabbia



XS	1 076200004
XXL	1 076200005

7631

pull in pile bilaminato 360 g,
grigio/blu



XS	1 076310000
S	1 076310001
M	1 076310002
L	1 076310003
XL	1 076310004
XXL	1 076310005
XXXL	1 076310006

7635

pull in micropile 180 g,
grigio



XS	1 076350010
S	1 076350011
M	1 076350012
L	1 076350013
XL	1 076350014
XXL	1 076350015
XXXL	1 076350016

7621

giacca in pile bilaminato 360 g,
grigio/blu



XS	1 076210000
S	1 076210001
M	1 076210002
L	1 076210003
XL	1 076210004
XXL	1 076210005
XXXL	1 076210006

7631

pull in pile bilaminato 360 g,
blu/grigio



XS	1 076310100
S	1 076310101
M	1 076310102
L	1 076310103
XL	1 076310104
XXL	1 076310105
XXXL	1 076310106

7640

felpa in 60% cotone, 40% poliestere 320 g
ricamo frontale, grigio



XS	1 076400000
S	1 076400001
M	1 076400002
L	1 076400003
XL	1 076400004
XXL	1 076400005
XXXL	1 076400006

7621

giacca in pile bilaminato 360 g,
blu/grigio



XS	1 076210100
S	1 076210101
M	1 076210102
L	1 076210103
XL	1 076210104
XXL	1 076210105
XXXL	1 076210106

7635

pull in micropile 180 g,
nero



XS	1 076350000
S	1 076350001
M	1 076350002
L	1 076350003
XL	1 076350004
XXL	1 076350005
XXXL	1 076350006

7640D

felpa in 60% cotone, 40% poliestere 320 g
ricamo piccolo posteriore, grigio



XS	1 076400100
S	1 076400101
M	1 076400102
L	1 076400103
XL	1 076400104
XXL	1 076400105
XXXL	1 076400106

7640D

felpa in 60% cotone, 40% poliestere 320 g
ricamo piccolo posteriore, blu



XS	1 076400120
S	1 076400121
M	1 076400122
L	1 076400123
XL	1 076400124
XXL	1 076400125
XXXL	1 076400126

7691

bomber pesante in nylon doobby 180 g
impermeabilizzato, imbottito e foderato,
ghiaccio



S	1 076910001
M	1 076910002
L	1 076910003
XL	1 076910004
XXL	1 076910005

7694

bomber in poliestere Oxford brushed
impermeabilizzato, imbottito e foderato,
nero



XS	1 076940000
S	1 076940001
M	1 076940002
L	1 076940003
XL	1 076940004
XXL	1 076940005
XXXL	1 076940006

7690

bomber leggero in TC/PU 180 g
foderato, sabbia



S	1 076900001
M	1 076900002
L	1 076900003
XL	1 076900004
XXL	1 076900005

7692

bomber in poliestere Ripstop
impermeabilizzato, imbottito e foderato,
blu/grigio



XS	1 076920000
S	1 076920001
M	1 076920002
L	1 076920003
XL	1 076920004
XXL	1 076920005
XXXL	1 076920006

7700

giacca leggera in "Oxford" 165 g
foderata e impermeabilizzata, sabbia



S	1 077000001
M	1 077000002
L	1 077000003
XL	1 077000004
XXL	1 077000005

7690

bomber leggero in TC/PU 180 g
foderato, blu



S	1 076900101
M	1 076900102
L	1 076900103
XL	1 076900104
XXL	1 076900105

7693

giubbino in jeans denim 100% cotone
10 once, foderato in T/C canvas



S	1 076930001
M	1 076930002
L	1 076930003
XL	1 076930004
XXL	1 076930005

7700

giacca leggera in "Oxford" 165 g
foderata e impermeabilizzata, blu



S	1 077000101
M	1 077000102
XL	1 077000104
XXL	1 077000105

7700

giacca leggera in "Oxford" 165 g
foderata e impermeabilizzata, grigio



M	1 077000202
L	1 077000203
XL	1 077000204
XXL	1 077000205

7720

parka in ripstop impermeabilizzato,
antracite/grigio



S	1 077200101
M	1 077200102
XL	1 077200104
XXL	1 077200105

7732

parka sfoderabile in "Taslon"
impermeabilizzato
nero/blu. Interno in pile



XS	1 077320000
S	1 077320001
M	1 077320002
L	1 077320003
XL	1 077320004
XXL	1 077320005
XXXL	1 077320006

7701

spolverino impermeabile in PU/TC,
blu



S	1 077010001
M	1 077010002
L	1 077010003
XL	1 077010004
XXL	1 077010005

7722

parka in twill stampato di poliestere
impermeabilizzato, imbottito e foderato, grigio



XS	1 077220000
S	1 077220001
M	1 077220002
L	1 077220003
XL	1 077220004
XXL	1 077220005
XXXL	1 077220006

7740

parka in T/C canvas 290 g
imbottito, foderato e trapuntato,
sabbia



S	1 077400001
M	1 077400002
L	1 077400003
XL	1 077400004
XXL	1 077400005

7720

parka in ripstop impermeabilizzato,
grigio/antracite



S	1 077200001
M	1 077200002
XL	1 077200004
XXL	1 077200005

7731

parka in "Taslon" impermeabilizzato
imbottito e foderato, nero. Indicato per basse
temperature



S	1 077310001
M	1 077310002
L	1 077310003
XL	1 077310004
XXL	1 077310005

7740

parka in T/C canvas 290 g
imbottito, foderato e trapuntato,
blu



S	1 077400101
M	1 077400102
L	1 077400103
XL	1 077400104
XXL	1 077400105

7740

parka in T/C canvas 290 g
imbottito, foderato e trapuntato,
marrone



Dimensione	Quantità	Articolo
S	1	077400201
M	1	077400202
L	1	077400203
XL	1	077400204
XXL	1	077400205

7760

giacca in "Oxford" 180 g impermeabilizzata,
imbottita e foderata, sabbia/grigio



Dimensione	Quantità	Articolo
S	1	077600001
M	1	077600002
L	1	077600003
XL	1	077600004
XXL	1	077600005

7760

giacca in "Oxford" 180 g impermeabilizzata,
imbottita e foderata, grigio/sabbia



Dimensione	Quantità	Articolo
L	1	077600103
XL	1	077600104
XXL	1	077600105

7770

giaccone sfoderabile in nylon "Taslon" 145 g,
sabbia
Interno Husky trapuntato 120 g



Dimensione	Quantità	Articolo
S	1	077700001
M	1	077700002
L	1	077700003
XXL	1	077700005

7790

piumino in microfibra Teijin®
e piuma d'oca 50/50 300 g,
maniche staccabili, arancio



Dimensione	Quantità	Articolo
S	1	077900001
M	1	077900002
L	1	077900003
XL	1	077900004
XXL	1	077900005

7800

pantaloni da lavoro in T/C twill 210 g,
inserti in Oxford, tabacco



Dimensione	Quantità	Articolo
XS	1	078000000
S	1	078000001
M	1	078000002
L	1	078000003
XL	1	078000004
XXL	1	078000005
XXXL	1	078000006

7800G

coppia ginocchiere da lavoro



Articolo	Quantità
7800G	1 078000500

7801

bermuda da lavoro in T/C twill 210 g,
inserti in Oxford, tabacco



Dimensione	Quantità	Articolo
XS	1	078010000
S	1	078010001
M	1	078010002
L	1	078010003
XL	1	078010004
XXL	1	078010005
XXXL	1	078010006

7803

salopette da lavoro in T/C twill 210 g,
inserti in Oxford, tabacco



XS	1 078030000
S	1 078030001
M	1 078030002
L	1 078030003
XL	1 078030004
XXL	1 078030005
XXXL	1 078030006

7805

tuta da lavoro in T/C twill 210 g,
inserti in Oxford, maniche staccabili
tabacco



XS	1 078050000
S	1 078050001
M	1 078050002
L	1 078050003
XL	1 078050004
XXL	1 078050005
XXXL	1 078050006

7807

gilet da lavoro in T/C twill 210 g,
inserti in Oxford, tabacco



XS	1 078070000
S	1 078070001
M	1 078070002
L	1 078070003
XL	1 078070004
XXL	1 078070005
XXXL	1 078070006

7808

grembiule da lavoro in T/C twill 210 g,
tabacco



M	1 078080002
XL	1 078080004

7809

giacca da lavoro in T/C twill 210 g,
inserti in Oxford, maniche staccabili
tabacco



XS	1 078090000
S	1 078090001
M	1 078090002
L	1 078090003
XL	1 078090004
XXL	1 078090005
XXXL	1 078090006

7840

pantaloni da lavoro in T/C twill 200 g
grigio/arancio



XS	1 078400000
S	1 078400001
M	1 078400002
L	1 078400003
XL	1 078400004
XXL	1 078400005
XXXL	1 078400006

7841

bermuda da lavoro in T/C twill 200 g
grigio/arancio



XS	1 078410000
S	1 078410001
M	1 078410002
L	1 078410003
XL	1 078410004
XXL	1 078410005
XXXL	1 078410006



7843

salopette da lavoro in T/C twill 200 g
grigio/arancio



Dimensione	Quantità	Articolo
XS	1	078430000
S	1	078430001
M	1	078430002
L	1	078430003
XL	1	078430004
XXL	1	078430005
XXXL	1	078430006

7849

giacca da lavoro in T/C twill 200 g
grigio/arancio



Dimensione	Quantità	Articolo
XS	1	078490000
S	1	078490001
M	1	078490002
L	1	078490003
XL	1	078490004
XXL	1	078490005
XXXL	1	078490006

7853

salopette da lavoro in T/C twill 180 g,
inserti in T/C Ripstop, sabbia



Dimensione	Quantità	Articolo
XS	1	078530000
S	1	078530001
M	1	078530002
L	1	078530003
XL	1	078530004
XXL	1	078530005
XXXL	1	078530006

7845

tuta leggera da lavoro in T/C twill 200 g
grigio/arancio



Dimensione	Quantità	Articolo
XS	1	078450000
S	1	078450001
M	1	078450002
L	1	078450003
XL	1	078450004
XXL	1	078450005
XXXL	1	078450006

7850

pantaloni da lavoro in T/C twill 180 g
con inserti in T/C Ripstop, sabbia



Dimensione	Quantità	Articolo
XS	1	078500000
S	1	078500001
M	1	078500002
L	1	078500003
XL	1	078500004
XXL	1	078500005
XXXL	1	078500006

7855

tuta leggera da lavoro in T/C twill 180 g
con inserti in T/C Ripstop, sabbia



Dimensione	Quantità	Articolo
XS	1	078550000
S	1	078550001
M	1	078550002
L	1	078550003
XL	1	078550004
XXL	1	078550005
XXXL	1	078550006

7857

gilet da lavoro in T/C twill 180 g
con inserti in T/C Ripstop, sabbia



Dimensione	Articolo
XS	1 078570000
S	1 078570001
M	1 078570002
L	1 078570003
XL	1 078570004
XXL	1 078570005
XXXL	1 078570006

7859

giacca da lavoro in T/C twill 180 g
con inserti in T/C Ripstop, sabbia



Dimensione	Articolo
XS	1 078590000
S	1 078590001
M	1 078590002
L	1 078590003
XL	1 078590004
XXL	1 078590005
XXXL	1 078590006

**7860**

pantaloni da lavoro in T/C twill 180 g
con inserti in T/C Ripstop, grigio



Dimensione	Articolo
XS	1 078600000
S	1 078600001
M	1 078600002
L	1 078600003
XL	1 078600004
XXL	1 078600005
XXXL	1 078600006

7861

bermuda da lavoro in T/C twill 180 g
con inserti in T/C Ripstop, grigio



Dimensione	Articolo
XS	1 078610000
S	1 078610001
M	1 078610002
L	1 078610003
XL	1 078610004
XXL	1 078610005
XXXL	1 078610006

7863

salopette da lavoro in T/C twill 180 g,
inserti in T/C Ripstop, grigio



Dimensione	Articolo
XS	1 078630000
S	1 078630001
M	1 078630002
L	1 078630003
XL	1 078630004
XXL	1 078630005
XXXL	1 078630006

7865

tuta leggera da lavoro in T/C twill 180 g
con inserti in T/C Ripstop, grigio



Dimensione	Articolo
XS	1 078650000
S	1 078650001
M	1 078650002
L	1 078650003
XL	1 078650004
XXL	1 078650005
XXXL	1 078650006



7867

gilet da lavoro in T/C twill 180 g
con inserti in T/C Ripstop, grigio



Dimensione	Quantità	Articolo
XS	1	078670000
S	1	078670001
M	1	078670002
L	1	078670003
XL	1	078670004
XXL	1	078670005
XXXL	1	078670006

7869

giacca da lavoro in T/C twill 180 g
con inserti in T/C Ripstop, grigio



Dimensione	Quantità	Articolo
XS	1	078690000
S	1	078690001
M	1	078690002
L	1	078690003
XL	1	078690004
XXL	1	078690005
XXXL	1	078690006

Beta
Collection

7870

pantaloni da lavoro in T/C twill 180 g
con inserti in T/C Ripstop, blu



Dimensione	Quantità	Articolo
XS	1	078700000
S	1	078700001
M	1	078700002
L	1	078700003
XL	1	078700004
XXL	1	078700005
XXXL	1	078700006

7871

bermuda da lavoro in T/C twill 180 g
con inserti in T/C Ripstop, blu



Dimensione	Quantità	Articolo
XS	1	078710000
S	1	078710001
M	1	078710002
L	1	078710003
XL	1	078710004
XXL	1	078710005
XXXL	1	078710006

7873

salopette da lavoro in T/C twill 180 g,
inserti in T/C Ripstop, blu



Dimensione	Quantità	Articolo
XS	1	078730000
S	1	078730001
M	1	078730002
L	1	078730003
XL	1	078730004
XXL	1	078730005
XXXL	1	078730006

7875

tuta leggera da lavoro in T/C twill 180 g
con inserti in T/C Ripstop, blu



Dimensione	Quantità	Articolo
XS	1	078750000
S	1	078750001
M	1	078750002
L	1	078750003
XL	1	078750004
XXL	1	078750005
XXXL	1	078750006

Beta



7877

gilet da lavoro in T/C twill 180 g
con inserti in T/C Ripstop, blu



Dimensione	Quantità	Articolo
XS	1	078770000
S	1	078770001
M	1	078770002
L	1	078770003
XL	1	078770004
XXL	1	078770005
XXXL	1	078770006

7879

giacca da lavoro in T/C twill 180 g
con inserti in T/C Ripstop, blu



Dimensione	Quantità	Articolo
XS	1	078790000
S	1	078790001
M	1	078790002
L	1	078790003
XL	1	078790004
XXL	1	078790005
XXXL	1	078790006

7899

gilet tecnico da lavoro
in T/C Canvas 270 g, grigio



Dimensione	Quantità	Articolo
M	1	078990002
XL	1	078990004

7900

pantaloni da lavoro in T/C canvas 270 g,
inserti in Oxford, grigio



Dimensione	Quantità	Articolo
XS	1	079000100
S	1	079000101
M	1	079000102
L	1	079000103
XL	1	079000104
XXL	1	079000105
XXXL	1	079000106

7901

bermuda da lavoro in T/C canvas 270 g,
inserti in Oxford, grigio



Dimensione	Quantità	Articolo
XS	1	079010100
S	1	079010101
M	1	079010102
L	1	079010103
XL	1	079010104
XXL	1	079010105
XXXL	1	079010106

7903

salopette da lavoro in T/C canvas 270 g,
inserti in Oxford, grigio



Dimensione	Quantità	Articolo
XS	1	079030100
S	1	079030101
M	1	079030102
L	1	079030103
XL	1	079030104
XXL	1	079030105
XXXL	1	079030106

7902

bomber da lavoro sfoderato
in T/C canvas 270 g,
inserti in Oxford, grigio



Dimensione	Quantità	Articolo
XS	1	079020100
S	1	079020101
M	1	079020102
L	1	079020103
XL	1	079020104
XXL	1	079020105
XXXL	1	079020106

7904

giacca da lavoro imbottita e foderata in T/C canvas 270 g, inserti in Oxford, grigio



Dimensione	Quantità	Articolo
XS	1	079040100
S	1	079040101
M	1	079040102
L	1	079040103
XL	1	079040104
XXL	1	079040105
XXXL	1	079040106

7905

tuta da lavoro in T/C canvas 270 g, inserti in Oxford, maniche staccabili grigio



Dimensione	Quantità	Articolo
XS	1	079050100
S	1	079050101
M	1	079050102
L	1	079050103
XL	1	079050104
XXL	1	079050105
XXXL	1	079050106

7907

giilet da lavoro in T/C canvas 270 g, inserti in Oxford, grigio



Dimensione	Quantità	Articolo
XS	1	079070100
S	1	079070101
M	1	079070102
L	1	079070103
XL	1	079070104
XXL	1	079070105
XXXL	1	079070106

7908

grebiule da lavoro in T/C canvas 270 g, grigio



Dimensione	Quantità	Articolo
M	1	079080102
XL	1	079080104

7909

giacca da lavoro in T/C canvas 270 g, inserti in Oxford, maniche staccabili grigio



Dimensione	Quantità	Articolo
XS	1	079090100
S	1	079090101
M	1	079090102
L	1	079090103
XL	1	079090104
XXL	1	079090105
XXXL	1	079090106

7950

pantaloni da lavoro in T/C canvas 270 g, inserti in T/C Ripstop, blu



Dimensione	Quantità	Articolo
XS	1	079500000
S	1	079500001
M	1	079500002
L	1	079500003
XL	1	079500004
XXL	1	079500005
XXXL	1	079500006

7951

bermuda da lavoro in T/C canvas 270 g, inserti in T/C Ripstop, blu



Dimensione	Quantità	Articolo
XS	1	079510000
S	1	079510001
M	1	079510002
L	1	079510003
XL	1	079510004
XXL	1	079510005
XXXL	1	079510006



7953

salopette da lavoro in T/C canvas 270 g,
inserti in T/C Ripstop, blu



Dimensione	Articolo
XS	1 079530000
S	1 079530001
M	1 079530002
L	1 079530003
XL	1 079530004
XXL	1 079530005
XXXL	1 079530006

7955

tuta da lavoro in T/C canvas 270 g,
inserti in T/C Ripstop, blu



Dimensione	Articolo
XS	1 079550000
S	1 079550001
M	1 079550002
L	1 079550003
XL	1 079550004
XXL	1 079550005
XXXL	1 079550006

7959

giacca da lavoro in T/C canvas 270 g,
inserti in T/C Ripstop, blu



Dimensione	Articolo
XS	1 079590000
S	1 079590001
M	1 079590002
L	1 079590003
XL	1 079590004
XXL	1 079590005
XXXL	1 079590006

7930

pantaloni da lavoro in 100% cotone 260 g,
grigio davy



Dimensione	Articolo
XS	1 079300000
S	1 079300001
M	1 079300002
L	1 079300003
XL	1 079300004
XXL	1 079300005
XXXL	1 079300006

7930

pantaloni da lavoro in 100% cotone 260 g,
grigio payne



Dimensione	Articolo
XS	1 079300100
S	1 079300101
M	1 079300102
L	1 079300103
XL	1 079300104
XXL	1 079300105
XXXL	1 079300106

7931

bermuda da lavoro in 100% cotone 260 g,
grigio davy



Dimensione	Articolo
XS	1 079310000
S	1 079310001
M	1 079310002
L	1 079310003
XL	1 079310004
XXL	1 079310005
XXXL	1 079310006

7931

bermuda da lavoro in 100% cotone 260 g,
grigio payne



Dimensione	Quantità	Articolo
XS	1	079310100
S	1	079310101
M	1	079310102
L	1	079310103
XL	1	079310104
XXL	1	079310105
XXXL	1	079310106

7933

salopette da lavoro in 100% cotone 260 g,
grigio davy



Dimensione	Quantità	Articolo
XS	1	079330000
S	1	079330001
M	1	079330002
L	1	079330003
XL	1	079330004
XXL	1	079330005
XXXL	1	079330006

7933

salopette da lavoro in 100% cotone 260 g,
grigio payne



Dimensione	Quantità	Articolo
XS	1	079330100
S	1	079330101
M	1	079330102
L	1	079330103
XL	1	079330104
XXL	1	079330105
XXXL	1	079330106

7935

tuta da lavoro in 100% cotone 260 g,
grigio davy



Dimensione	Quantità	Articolo
XS	1	079350000
S	1	079350001
M	1	079350002
L	1	079350003
XL	1	079350004
XXL	1	079350005
XXXL	1	079350006

7935

tuta da lavoro in 100% cotone 260 g,
grigio payne



Dimensione	Quantità	Articolo
XS	1	079350100
S	1	079350101
M	1	079350102
L	1	079350103
XL	1	079350104
XXL	1	079350105
XXXL	1	079350106

7937

giilet da lavoro in 100% cotone 260 g,
grigio davy



Dimensione	Quantità	Articolo
XS	1	079370000
S	1	079370001
M	1	079370002
L	1	079370003
XL	1	079370004
XXL	1	079370005
XXXL	1	079370006



7937

gilet da lavoro in 100% cotone 260 g,
grigio payne



XS	1 079370100
S	1 079370101
M	1 079370102
L	1 079370103
XL	1 079370104
XXL	1 079370105
XXXL	1 079370106

7939

giacca da lavoro in 100% cotone 260 g,
grigio davy



XS	1 079390000
S	1 079390001
M	1 079390002
L	1 079390003
XL	1 079390004
XXL	1 079390005
XXXL	1 079390006

7939

giacca da lavoro in 100% cotone 260 g,
grigio payne



XS	1 079390100
S	1 079390101
M	1 079390102
L	1 079390103
XL	1 079390104
XXL	1 079390105
XXXL	1 079390106

7970

pantaloni impermeabili in PVC Tricot,
blu



XS	1 079700000
S	1 079700001
M	1 079700002
L	1 079700003
XL	1 079700004
XXL	1 079700005

7970

pantaloni impermeabili in PVC Tricot,
giallo



XS	1 079700100
S	1 079700101
M	1 079700102
L	1 079700103
XL	1 079700104
XXL	1 079700105

7970

pantaloni impermeabili in PVC Tricot,
verde



XS	1 079700200
S	1 079700201
M	1 079700202
L	1 079700203
XL	1 079700204
XXL	1 079700205

7973

salopette impermeabile in PVC Tricot,
blu



XS	1 079730000
S	1 079730001
M	1 079730002
L	1 079730003
XL	1 079730004
XXL	1 079730005

7973

salopette impermeabile in PVC Tricot, giallo



XS	1	079730100
S	1	079730101
M	1	079730102
L	1	079730103
XL	1	079730104
XXL	1	079730105

7973

salopette impermeabile in PVC Tricot, verde



XS	1	079730200
S	1	079730201
M	1	079730202
L	1	079730203
XL	1	079730204
XXL	1	079730205

7979

giacca impermeabile in PVC Tricot, blu



S	1	079790001
M	1	079790002
L	1	079790003
XL	1	079790004
XXL	1	079790005

7979

giacca impermeabile in PVC Tricot, giallo



S	1	079790101
M	1	079790102
L	1	079790103
XL	1	079790104
XXL	1	079790105

7979

giacca impermeabile in PVC Tricot, verde



S	1	079790201
M	1	079790202
L	1	079790203
XL	1	079790204
XXL	1	079790205

7980

cappello anti-pioggia tascabile in PU nylon, nero



M	5	079800002
L	5	079800003
XL	5	079800004

7981

berretto in lana e Thinsulate™ 150 g, nero



M	5	079810002
XL	5	079810004

7982

cappellino in T/C canvas 270 g, grigio



7982	5	079820009
------	---	-----------

7983

cappellino in T/C twill 210 g, tabacco



7983	5	079830009
------	---	-----------

C62EV/WO

espositore a manichino

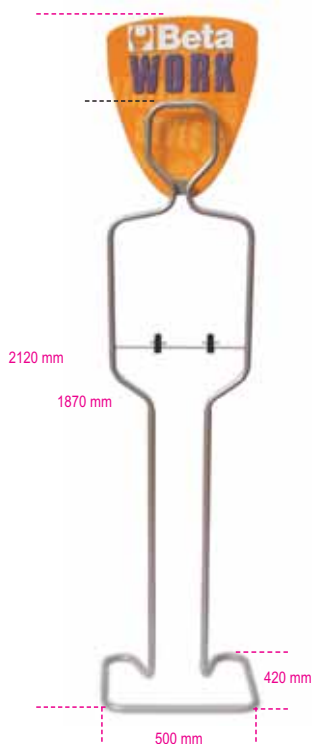

C62EV/WO 1 062000320

C62EV/WW

espositore per abbigliamento con predisposizione per calzature

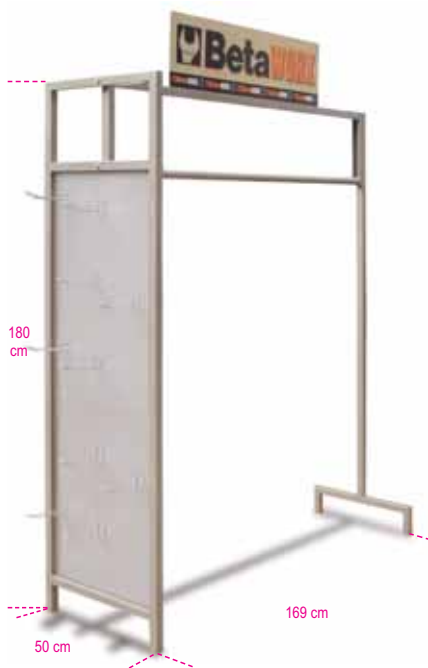

C62EV/WW 1 062000500

ACCESSORI C62

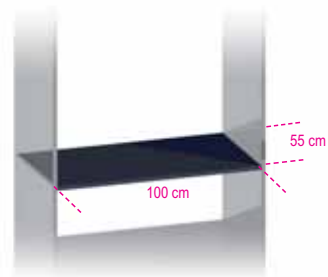

C62/R 1 062000050

C62EV/C

espositore per calzature, 10 posizioni



C62EV/C 1 062000100

C62

espositore per abbigliamento con predisposizione per calzature

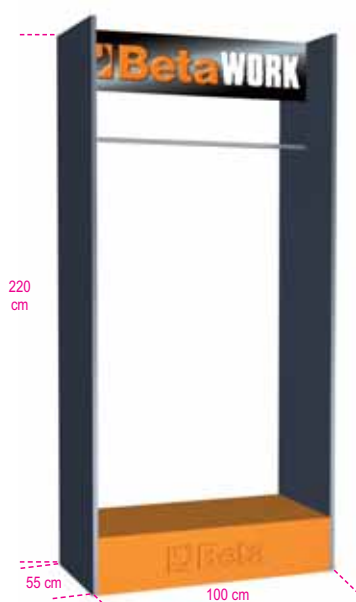

C62/1	1 m	1 062000001
C62/2	2 m	1 062000002
C62/3	3 m	1 062000003
C62/4	4 m	1 062000004

Beta





Gamma blister *per la tua vendita a libero servizio!*



Efficienza espositiva

Migliore visibilità

Codice a barre

SUPPORTO BLISTER:

- PVC Antistrappo
- 3 formati
- Sistema di fissaggio di nuova generazione con fascetta elastica

42K

mm		
6x6	10	000429006
7x7	10	000429007
8x8	10	000429008
9x9	10	000429009
10x10	10	000429010
11x11	10	000429011
12x12	10	000429012
13x13	10	000429013
14x14	10	000429014
15x15	10	000429015
16x16	10	000429016
17x17	10	000429017
18x18	10	000429018
19x19	10	000429019
20x20	5	000429020
21x21	5	000429021
22x22	5	000429022
23x23	5	000429023
24x24	5	000429024
27x27	5	000429027
30x30	5	000429030
32x32	5	000429032

55K

mm		
6x7	10	000559012
8x9	10	000559021
10x11	10	000559030
12x13	10	000559042
14x15	10	000559054
16x17	10	000559060
18x19	5	000559066
20x22	5	000559075

93K

mm		
21x22	3	000939021

96/PL7K

96PL7K 2,5-3-4-5-6-8-10	1	000969371

96/SP9K

96/SP9K 1,5-2-2,5-3 4-5-6-8-10	5	000969384

96TK

mm		
2	5	000969934
2,5	5	000969935
3	5	000969936
4	5	000969938
5	5	000969940
6	5	000969941

110K

L mm		
150	5	001109150
200	5	001109200
250	5	001109250

142K

L mm		
8	3	001429008
10	3	001429010
13	3	001429013
17	2	001429017
19	2	001429019

195K

mm		
8x10	2	001959010
12x13	2	001959013
14x15	2	001959015
16x18	2	001959018
17x19	2	001959019

900K

mm		
14		
4	10	009009040
4,5	10	009009045
5	10	009009050
5,5	10	009009055
6	10	009009060
7	10	009009070
8	10	009009080
9	10	009009090
10	10	009009100
11	10	009009110
12	10	009009120
13	10	009009130
14	10	009009140

Beta

900/20LK

14"



L mm		
100	5	009009819

900/25K

14"



L mm		
41	5	009009830

900/30K

14"



L mm		
176	5	009009835

900/55K

14"



L mm		
125	5	009009870

920AK

12"



mm		
10	10	009209010
11	10	009209011
12	10	009209012
13	10	009209013
14	10	009209014
15	10	009209015
16	10	009209016
17	10	009209017
18	10	009209018
19	10	009209019
20	5	009209020
21	5	009209021
22	5	009209022
23	5	009209023
24	5	009209024
25	5	009209025
26	5	009209026
27	5	009209027
28	5	009209028
29	5	009209029
30	5	009209030
32	5	009209032

920/21K

12"



L mm		
125	5	009209822

920/25K

12"



L mm		
75	5	009209830

920/55K

12"



L mm		
275	3	009209882

935K

mm		
6x7	5	009359105
8x9	5	009359111
10x11	5	009359115
12x13	5	009359117
14x15	5	009359126
16x17	5	009359128
18x19	5	009359131
20x22	3	009359138

937K

mm		
6x6	5	009379006
7x7	5	009379007
8x8	5	009379008
9x9	5	009379009
10x10	5	009379010
11x11	5	009379011
12x12	5	009379012
13x13	5	009379013
14x14	5	009379014
15x15	5	009379015
16x16	5	009379016
17x17	5	009379017
18x18	5	009379018
19x19	5	009379019
20x20	5	009379020
21x21	3	009379021
22x22	3	009379022

951K

mm		
2,5	5	009519525
3	5	009519530
4	5	009519540
5	5	009519550
6	5	009519560
8	5	009519580

1032K

L mm		
180	5	010329017

1034K

L -		
170	5	010349017

1036K

L -		
175	5	010369017

1038K

L -		
175	5	010389017

1044K

L -		
240	5	010449240

1048VK

L ~
240 5 010489024

1048K

L ~
240 5 010489240

1052K

L ~
190 3 010529019
240 3 010529024

1082BMK

L ~
160 3 010829036

1084BMK

L ~
160 3 010849036

1098K

L ~
190 5 010989190
220 5 010989220

1122K

L ~
250 2 011229020

1123K

L ~
250 2 011239020

1124K

L ~
250 2 011249020

1129BMK

L mm
145 5 011299000

1142BMK

L mm
160 3 011429036

1150BMK

L ~
160 3 011509036
180 3 011509038
200 3 011509040

1162BMK

L ~
160 3 011629036

1166BMK

L ~
160 3 011669036

1168BMK

L ~
160 3 011689036



1201K



SxAxL mm		
0,4x2,5x50	5	012019003
0,5x3x75	5	012019009
0,6x3,5x100	5	012019021
0,8x4x100	5	012019030
0,8x4x125	5	012019033
1,0x5,5x100	5	012019039
1,0x5,5x150	5	012019042
1,2x6,5x150	5	012019051
1,2x8x150	3	012019057
1,6x10x200	3	012019066

1201NK

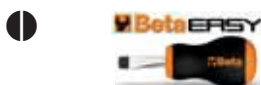

SxAxL mm		
0,8x4x30	3	012019103
1,2x6,5x30	3	012019106

1202K



PHxDxL mm		
0x3x60	5	012029003
1x4,5x80	5	012029009
2x6x100	5	012029018
3x8x150	3	012029024

1202NK



PHxDxL mm		
1x4,5x30	3	012029103
2x6x30	3	012029106

1207TXK



T6	5	012079006
T7	5	012079007
T8	5	012079008
T9	5	012079009
T10	5	012079010
T15	5	012079015
T20	5	012079020
T25	5	012079025
T27	5	012079027
T30	5	012079030

1209PZK



PZ		
0	5	012099000
1	5	012099003
2	5	012099006
3	3	012099009

1603B/K



0÷8	2	016039010

1741K



Ø mm	2,4	3	3,2	4	4,8
Alluminio	•	•	•	•	•
Acciaio	•	•	•	•	•

1741K		
	1	017419001

1762K



Ø mm		
2-2,5-3	2	017629001
3,5-4-4,5		

1770A/K



1770A/K		
	10	017709025



Beta
SHOP
in shop

Beta SHOP in Shop

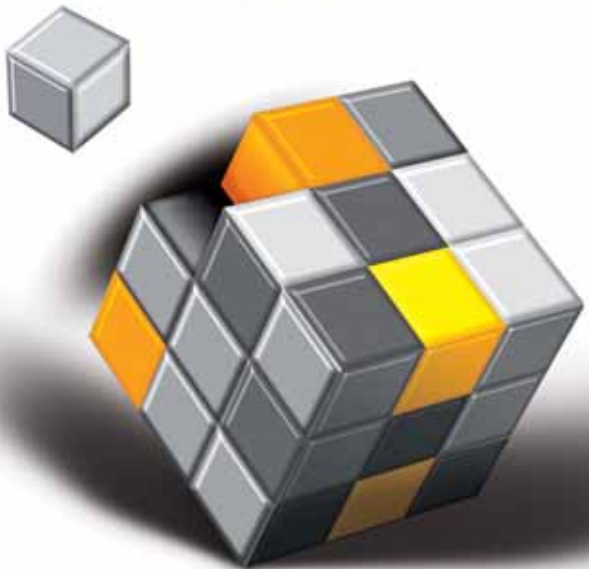
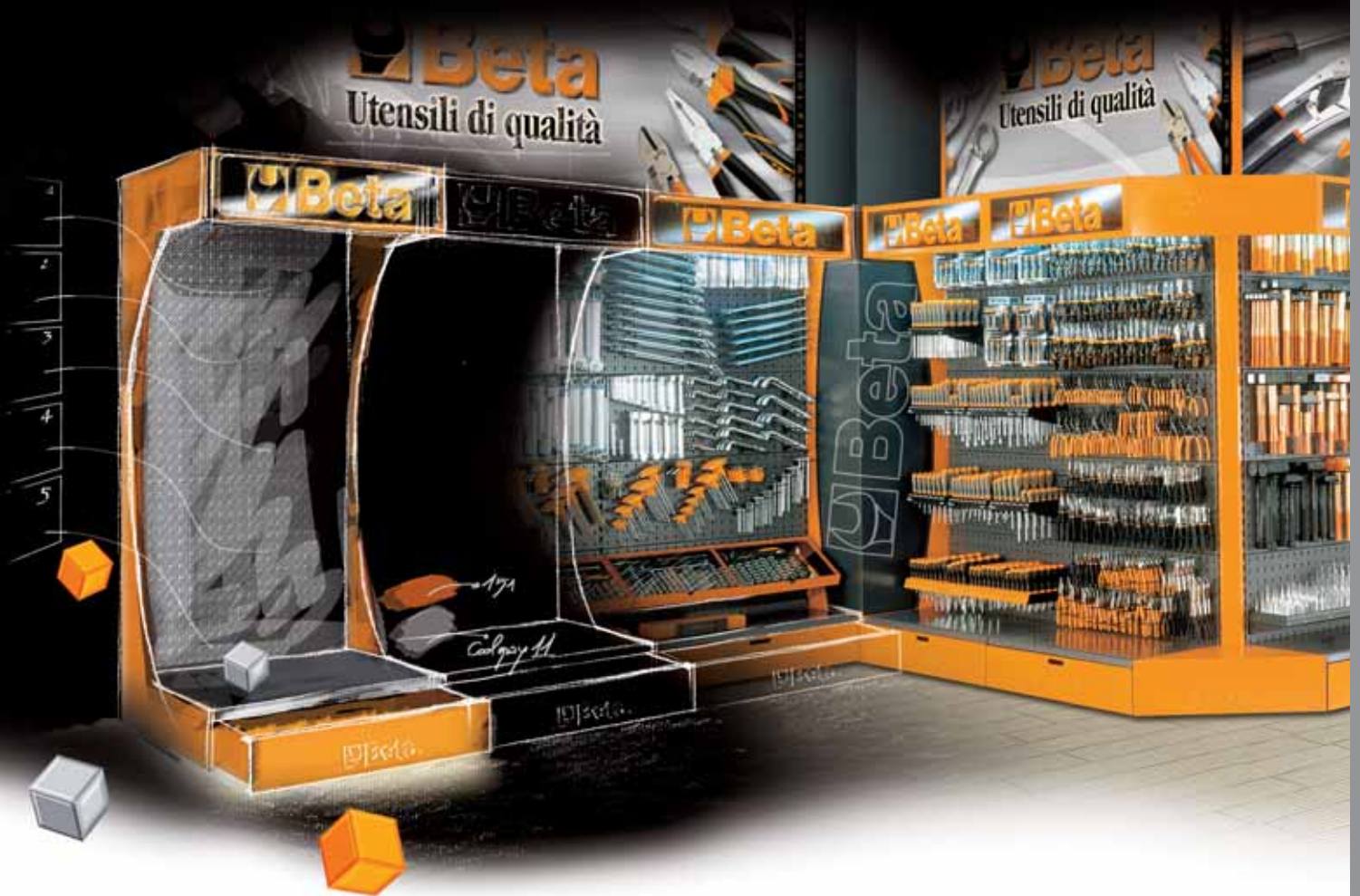

**SOLUZIONI
ESPOSITIVE
PER IL PUNTO
VENDITA**

38/DS1

espositore da parete
con 75 utensili a percussione



495x260x332 mm

Espositore
con assortimento



38/DS1 1 000380701

n.

30	Ø 2 - 3 - 4 - 5 - 6 mm	5
31	Ø 2 - 3 - 4 - 5 - 6 - 8 - 10 mm	5
32	Ø 3 - 4 - 5 mm	5

Espositore
vuoto



38/DVS1 1 000380751

38/DS2

espositore da parete
con 65 utensili a percussione

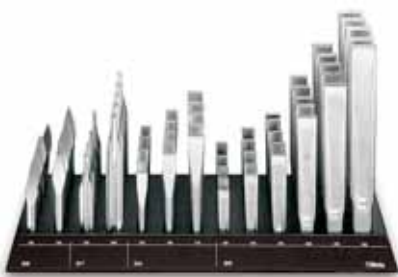

495x260x332 mm

Espositore
con assortimento



38/DS2 1 000380702

n.

34	125 - 150 - 175 mm	5
35	100 - 125 - 150 - 200 - 250 - 300 mm	5
36	125 - 150 mm	5
37	150 - 200 mm	5

Espositore
vuoto



38/DVS2 1 000380752

942BX/DG

espositore da parete
con 43 chiavi a bussola esagonale
con impugnatura tipo corto



330x260x332 mm

Espositore
con assortimento



942BX/DG 1 009420701

n.

942BX	5 - 5,5 mm	3
	6 - 7 mm	6
	8 - 9 - 10 mm	5
	11 mm	2
	12 mm	3
	13 mm	5

Espositore
vuoto



942BX/DVG 1 009420751

942BM/DG

espositore da parete
con 43 chiavi a bussola esagonale
con impugnatura tipo corto



330x260x332 mm

Espositore
con assortimento



942BM/DG 1 009420702

n.

942BM	5 - 5,5 mm	3
	6 - 7 mm	6
	8 - 9 - 10 mm	5
	11 mm	2
	12 mm	3
	13 mm	5

Espositore
vuoto



942BM/DVG 1 009420751

943BX/DG

espositore da parete
con 43 chiavi a bussola esagonale
con impugnatura tipo lungo



330x260x332 mm

Espositore
con assortimento



943BX/DG 1 009430701

n.

943BX	5 - 5,5 mm	3
	6 - 7 mm	6
	8 - 9 - 10 mm	5
	11 mm	2
	12 mm	3
	13 mm	5

Espositore
vuoto



943BX/DVG 1 009430751

943BM/DG

espositore da parete
con 43 chiavi a bussola esagonale
con impugnatura tipo lungo



330x260x332 mm

Espositore
con assortimento



943BM/DG 1 009430702

n.

943BM	5 - 5,5 mm	3
	6 - 7 mm	6
	8 - 9 - 10 mm	5
	11 mm	2
	12 mm	3
	13 mm	5

Espositore
vuoto



943BM/DVG 1 009430751

943/E1

espositore da banco
con 70 chiavi a bussola esagonale
con impugnatura



530x260x435 mm

Espositore
con assortimento



943/E1 1 009430650

		n.
⊖ 942BM	5,5 - 6 - 7 - 8 - 10 mm	6
	13 mm	5
⊖ 943BM	5,5 - 6 - 7 - 8 - 10 mm	6
	13 mm	5

Espositore
vuoto



943/EV1 1 009430651

943MQ/DG

espositore da parete
con 30 chiavi a bussola esagonale
con impugnatura



⚡ 1000 V

330x260x332 mm

Espositore
con assortimento



943MQ/DG 1 009430981

		n.
⊖ 943MQ	5,5 - 6 - 7 - 8 - 10 - 13 mm	5

Espositore
vuoto



943MQ/DVG 1 009430985

1203/E1P

espositore da parete
con 82 giravite



495x260x310 mm

Espositore
con assortimento



1203/E1P 1 012030301

		n.
⊖ 1201	0,4x2,5x50 - 0,5x3x75 - 0,6x3,5x100 0,8x4x100 - 0,8x4x125 mm	7
	1,0x5,5x100 - 1,0x5,5x150 - 1,2x6,5x150 mm	6
	1,2x8x150 mm	5
⊕ 1202	PH0x3x60 mm	7
	PH1x4,5x80 - PH2x6x100 mm	6
	PH3x8x150 mm	5

Espositore
vuoto



1203/EV1P 1 012030351

1203/E4P

espositore da parete
con 85 giravite



495x260x310 mm

Espositore
con assortimento



1203/E4P 1 012030304

		n.
⊖ 1201	0,4x2,5x50 - 0,5x3x75 - 0,8x4x125 mm	7
	1,0x5,5x100 - 1,0x5,5x150 - 1,2x6,5x150 mm	6
⊖ 1204	0,4x2,5x60 - 0,5x3x100 - 0,8x4x100 mm	7
	1,0x5x125 mm	6
⊕ 1209PZ	PZ0x3x60 mm	7
	PZ1x4,5x80 - PZ2x6x100 mm	6

Espositore
vuoto



1203/EV4P 1 012030354

1203/E5P

espositore da parete
con 82 giravite



495x260x310 mm

Espositore
con assortimento



1203/E5P 1 012030305

		n.
⊕ 1202	PH0x3x60 mm	7
	PH1x4,5x80 - PH1x4,5x120 PH2x6x100 - PH2x6x150 mm	6
	PH3x8x150 mm	5
⊖ 1204	0,4x2,5x60 - 0,5x3x100 - 0,8x4x100 mm	7
	1,0x5x125 mm	6
⊕ 1209PZ	PZ0x3x60 mm	7
	PZ1x4,5x80 - PZ2x6x100 mm	6

Espositore
vuoto



1203/EV5P 1 012030355

1203/E10P

espositore da parete
con 80 giravite



495x260x310 mm

Espositore
con assortimento



1203/E10P 1 012030310

		n.
⊖ 1207TX	T6	4
	T7	3
	T8	7
	T9 - T10 - T15 - T20 - T25	6
	T27 - T30	3
⊕ 1208RTX	T9 - T10	3
	T15 - T20 - T25	6
	T27 - T30	3

Espositore
vuoto



1203/EV10P 1 012030360

1273/E160

espositore da banco
con 160 giravite



780x280x460 mm

Espositore
con assortimento
1273/E160

1 012730120

	n.
● 1270 2,5x50 - 2,5x75 mm	4
3x100 - 3,5x75 - 3,5x100 - 4x100 - 4x125 mm	8
5,5x100 - 5,5x150 - 6,5x150 mm	7
8x200 - 10x200 mm	3
● 1270N 4x30 - 6,5x30 mm	3
⊕ 1272 3x60 - 3x100 mm	8
4,5x80 - 4,5x120 - 6x100 - 6x150 mm	7
8x150 mm	6
⊕ 1272N 4,5x30 - 6x30 mm	3
● 1274 2,5x60 - 3x100 mm	8
4x100 mm	4
5x125 mm	3

Espositore
vuoto
1273/EV160

1 012730121

1273/E160P

espositore da parete
con 160 giravite

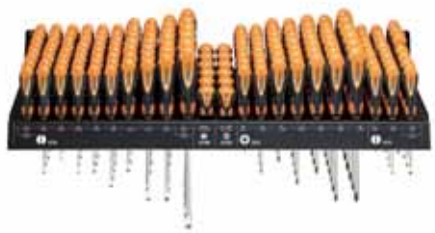

745x280x335 mm

Espositore
con assortimento
1273/E160P

1 012730123

	n.
● 1270 2,5x50 - 2,5x75 mm	4
3x100 - 3,5x75 - 3,5x100 - 4x100 - 4x125 mm	8
5,5x100 - 5,5x150 - 6,5x150 mm	7
8x200 - 10x200 mm	3
● 1270N 4x30 - 6,5x30 mm	3
⊕ 1272 3x60 - 3x100 mm	8
4,5x80 - 4,5x120 - 6x100 - 6x150 mm	7
8x150 mm	6
⊕ 1272N 4,5x30 - 6x30 mm	3
● 1274 2,5x60 - 3x100 mm	8
4x100 mm	4
5x125 mm	3

Espositore
vuoto
1273/EV160P

1 012730124

1273/E1

espositore da banco
con 92 giravite



530x260x435 mm

Espositore
con assortimento
1273/E1

1 012730201

	n.
● 1270 2,5x50 - 3x75 - 3,5x100 - 4x125 - 5,5x150 mm	7
6,5x150 mm	6
8x200 - 10x200 mm	3
● 1270N 4x30 - 6,5x30 mm	3
⊕ 1272 3x60 - 4,5x80 - 4,5x120 mm	7
6x100 mm	6
6x150 - 8x150 mm	3
⊕ 1272N 4,5x30 - 6x30 mm	3

Espositore
vuoto
1273/EV1

1 012730251

1273/E1P

espositore da parete
con 92 giravite



495x260x310 mm

Espositore
con assortimento
1273/E1P

1 012730301

	n.
● 1270 2,5x50 - 3x75 - 3,5x100 - 4x125 - 5,5x150 mm	7
6,5x150 mm	6
8x200 - 10x200 mm	3
● 1270N 4x30 - 6,5x30 mm	3
⊕ 1272 3x60 - 4,5x80 - 4,5x120 mm	7
6x100 mm	6
6x150 - 8x150 mm	3
⊕ 1272N 4,5x30 - 6x30 mm	3

Espositore
vuoto
1273/EV1P

1 012730351

1273/E4P

espositore da parete
con 100 giravite



495x260x310 mm

Espositore
con assortimento
1273/E4P

1 012730304

	n.
● 1270 2,5x50 - 3x75 - 3x100 - 3,5x100 4x75 - 4x125 - 5,5x150 mm	7
6,5x150 mm	6
8x200 - 10x200 mm	3
● 1270E 10x175 mm	3
12x200 mm	2
● 1270N 4x30 - 6,5x30 mm	3
● 1274 2,5x60 - 3x100 - 4x100 - 5x125 mm	7

Espositore
vuoto
1273/EV4P

1 012730354

1273/E5P

espositore da parete
con 91 giravite

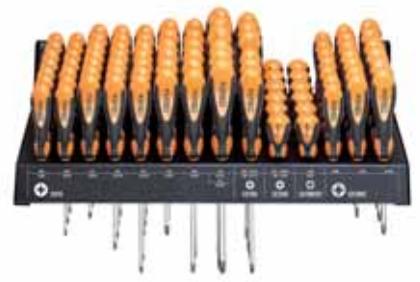

495x260x310 mm

Espositore
con assortimento
1273/E5P

1 012730305

	n.
⊕ 1272 3x60 - 3x100 - 4,5x80 - 4,5x120 - 4,5x150 mm	7
6x100 - 6x150 mm	6
8x150 - 10x200 mm	3
⊕ 1272E 6x150 - 8x175 mm	3
⊕ 1272N 4,5x30 - 6x30 mm	3
⊕ 1279PZ 0x60 - 1x80 mm	7
2x100 mm	6
⊕ 1279N/PZ 1x30 - 2x30 mm	3

Espositore
vuoto
1273/EV5P

1 012730355

1273/E10P

espositore da parete
con 96 giravite

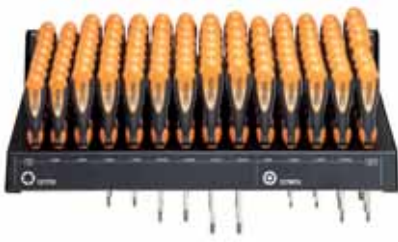

495x260x310 mm

Espositore
con assortimento
1273/E10P 1 012730310

	n.
1277TX T6x50 mm	3
T7x50 mm	4
T8x60 - T9x60 - T10x80	7
T15x80 - T20x100 - T25x100 mm	7
T27x115 - T30x115 mm	6
1278RTX T9x60 - T10x80 - T15x80 - T20x100 mm	7
T25x100 mm	4
T30x115 mm	3

Espositore
vuoto
1273/EV10P 1 012730360

1293BX/DA

espositore da parete
con 90 giravite



495x260x332 mm

Espositore
con assortimento
1293BX/DA 1 012930701

	n.
1290 3x75 - 3,5x100 - 4x100 - 4x125 - 5,5x100 - 5,5x150 mm	7
6,5x150 mm	6
8x150 mm	3
10x200 mm	2
1290N 4x30 - 6,5x30 mm	3
1292 PH0x60 - PH1x80 mm	7
PH2x100 mm	6
PH3x150 mm	5
1292N PH1x30 - PH2x30 mm	3

Espositore
vuoto
1293BX/DVA 1 012930751

1293BX/DC

espositore da parete
con 80 giravite



495x260x332 mm

Espositore
con assortimento
1293BX/DC 1 012930703

	n.
1292 PH0x60 - PH0x100 - PH1x80 - PH1x120 - PH1x150 mm	7
PH2x100 - PH2x150 mm	6
PH3x150 - PH4x200 mm	5
1292N PH1x30 - PH2x30 mm	6
1292E PH2x150 mm	6
PH3x175 mm	5

Espositore
vuoto
1293BX/DVC 1 012930753

1273MQ/E1

espositore da parete
con 40 giravite



1000 V

330x260x332 mm

Espositore
con assortimento
1273MQ/E1 1 012730311

	n.
1272MQ PH0x60 - PH1x80 mm	5
PH2x100 mm	3
PH3x150 mm	2
1274MQ 3x100 - 4x100 - 5,5x125 - 6,5x150 mm	5
8x175 mm	3
10x200 mm	2

Espositore
vuoto
1273MQ/DVG 1 012730751

1293BX/DB

espositore da parete
con 89 giravite



495x260x332 mm

Espositore
con assortimento
1293BX/DB 1 012930702

	n.
1290 2,5x50 - 3x75 - 3x100 - 3,5x100 - 4x100 - 4x125 - 5,5x100 - 5,5x150 mm	7
6,5x150 mm	6
8x150 mm	5
1290N 4x30 - 6,5x30 mm	6
1290E 10x175 - 12x200 mm	5

Espositore
vuoto
1293BX/DVB 1 012930752

1293BX/DD

espositore da parete
con 48 giravite



330x260x332 mm

Espositore
con assortimento
1293BX/DD 1 012930704

	n.
1294 2,5x60 - 3x75 - 3x100 - 4x100 - 4x150 - 5x125 mm	7
6,5x150 mm	6

Espositore
vuoto
1293BX/DVD 1 012930754

1293BX/DE

espositore da parete
con 42 giravite



330x260x332 mm

Espositore
con assortimento



1293BX/DE 1 012930705

n.

➕ 1299PZ	PZ0x60 - PZ1x80 mm	7
	PZ2x100 mm	6
	PZ3x150 - PZ4x200 mm	5
➕ 1299N/PZ	PZ1x30 - PZ2x30 mm	6

Espositore
vuoto



1293BX/DVE 1 012930755

1293BX/DF

espositore da parete
con 59 giravite



330x260x332 mm

Espositore
con assortimento



1293BX/DF 1 012930706

n.

⊖ 1297TX	T6 - T8 - T10 - T15 - T20 - T25	7
	T27 - T30	6
	T40	5

Espositore
vuoto



1293BX/DVF 1 012930756

1293BX/E159

espositore da banco
con 159 giravite



620x320x450 mm

Espositore
con assortimento



1293BX/E159 1 012930120

n.

⊖ 1290	2,5x50 - 2,5x75 mm	4
	3x75 - 3,5x100 - 3,5x125 - 4x75	8
	4x100 - 4x125 mm	
	5,5x100 - 5,5x150 - 6,5x100 - 6,5x150 mm	7
	8x200 - 10x200 mm	3
⊖ 1290N	4x30 - 6,5x30 mm	3
➕ 1292	PH0x60 - PH0x100 mm	8
	PH1x80 - PH1x120 - PH1x150	7
	PH2x100 - PH2x150 mm	
	PH3x150 mm	6
➕ 1292N	PH1x30 - PH2x30 mm	3

Espositore
vuoto



1293BX/EV159 1 012930121

C60

espositore da parete
vuoto



500x520x2000 mm

C60



1 060000020

C61

espositore da parete
vuoto



1000x520x2000 mm

C61



1 060010020

ACCESSORI

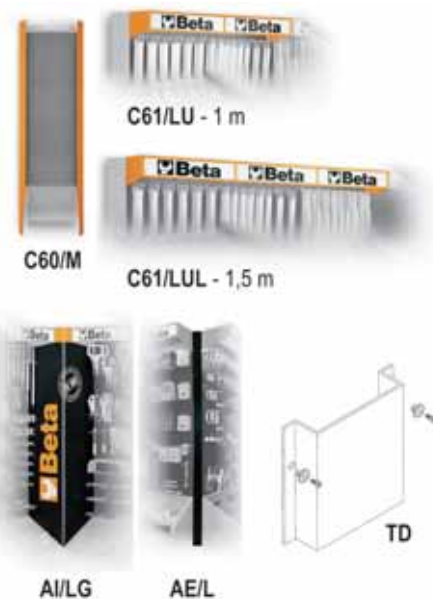

C60/M	1 060000030
C61/LU	1 060010102
C61/LUL	1 060010103
AE/L	1 060040501
A1/LG	1 060040502
TD	1 088880080

C68

parete espositiva vuota Beta



1000x560x2200 mm

C68/1	1 m	1	068000001
C68/2	2 m	1	068000002
C68/3	3 m	1	068000003
C68/4	4 m	1	068000004
C68/5	5 m	1	068000005
C68/6	6 m	1	068000006
C68/7	7 m	1	068000007
C68/8	8 m	1	068000008
C68/9	9 m	1	068000009
C68/10	10 m	1	068000010

C88 R/1

parete espositiva vuota Robur



1000x560x2200 mm

C88 R/1	1	088000001
---------	---	-----------

ACCESSORI C68



VE/180



VE/90

6800 VE/180	1	068000120
6800 VE/90	1	068000125



AE



AI



AD/P

6800 AE	1	068000145
6800 AI	1	068000140
6800 AD/P	1	068000143



CB/100



FB/100



FO/100



PL



RP/100



GR/37

6800 CB/100	1	068000104
6800 FB/100	1	068000109
6800 FO/100	1	068000108
6800 PL	1	068000137
6800 RP/100	1	068000150
6800 GR/37	1	068000159

C68 G

gondola espositiva vuota



1000x1120x1600 mm

C68 G/1	1 m	1	068000051
C68 G/2	2 m	1	068000052
C68 G/3	3 m	1	068000053
C68 G/4	4 m	1	068000054

Beta

6888

ganci per espositori C60 - C61 - C68 - C88



6888 S1	10	068880011
6888 S2	10	068880012
6888 D1	5	068880021
6888 D2	5	068880022
6888 D4	5	068880024
6888 D5	5	068880025
6888 T1	5	068880031
6888 T2	5	068880032
6888 CT	1	068880044



RS



BA



PM/40



PM/80

6800 BA	1	068000130
6800 RS	1	068000135
6800 PM/40	1	068000171
6800 PM/80	1	068000172



6600 M/10

assortimento 178 utensili,
con ganci senza pannello



6600 M/10



1 066000010

6600 M/27

assortimento 25 utensili,
con ganci senza pannello



6600 M/27



1 066000027

6600 M/40

assortimento 100 utensili,
con ganci senza pannello

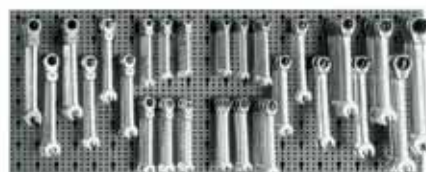

6600 M/40



1 066000040

6600 M/15

assortimento 118 utensili,
con ganci senza pannello

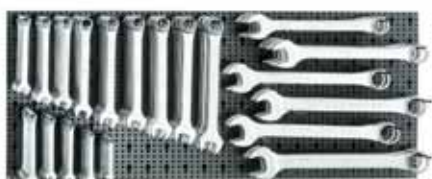

6600 M/15



1 066000015

6600 M/30

assortimento 18 utensili,
con ganci senza pannello



6600 M/30



1 066000030

6600 M/47

assortimento 65 utensili,
con ganci senza pannello



6600 M/47



1 066000047

6600 M/20

assortimento 150 utensili,
con ganci senza pannello

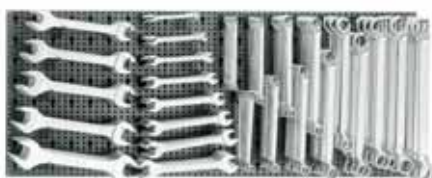

6600 M/20



1 066000020

6600 M/36

assortimento 107 utensili,
con ganci senza pannello



6600 M/36



1 066000036

6600 M/50

assortimento 257 utensili,
con ganci senza pannello



6600 M/50



1 066000050

6600 M/25

assortimento 130 utensili,
con ganci senza pannello



6600 M/25



1 066000025

6600 M/39

assortimento 77 utensili,
con ganci senza pannello



6600 M/39



1 066000039

6600 M/53

assortimento 191 utensili,
con ganci senza pannello



6600 M/53



1 066000053

6600 M/55

assortimento 150 utensili,
con ganci senza pannello



6600 M/55



6600 M/66

assortimento 80 utensili,
con ganci senza pannello



6600 M/66



6600 M/110

assortimento 329 utensili,
con ganci senza pannello



6600 M/110



6600 M/60

assortimento 118 utensili,
con ganci senza pannello

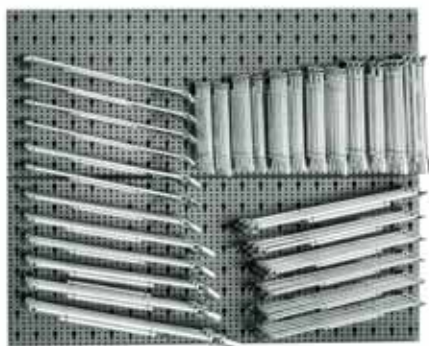

6600 M/60



6600 M/70

assortimento 107 utensili,
con ganci senza pannello



6600 M/70



6600 M/115

assortimento 306 utensili,
con ganci senza pannello



6600 M/115



6600 M/64

assortimento 104 utensili,
con ganci senza pannello



6600 M/64



6600 M/71

assortimento 107 utensili,
con ganci senza pannello



6600 M/71



6600 M/120

assortimento 163 utensili,
con ganci senza pannello



6600 M/120



6600 M/72

assortimento 107 utensili,
con ganci senza pannello



6600 M/72



6600 M/125

assortimento 133 utensili,
con ganci senza pannello



6600 M/125



 **Beta**



6600 M/131

assortimento 92 utensili,
con ganci senza pannello



6600 M/131



1 066000131

6600 M/215

assortimento 83 utensili,
con ganci senza pannello

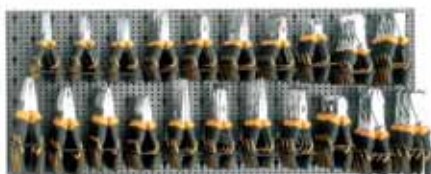

6600 M/215



1 066000215

6600 M/240

assortimento 47 utensili,
con ganci senza pannello



6600 M/240



1 066000240

6600 M/150

assortimento 14 utensili,
con ganci senza pannello

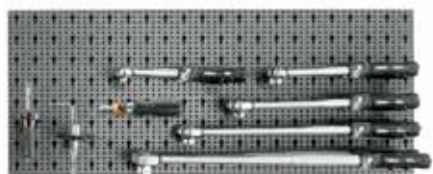

6600 M/150



1 066000150

6600 M/220

assortimento 83 utensili,
con ganci senza pannello



6600 M/220



1 066000220

6600 M/245

assortimento 91 utensili,
con ganci senza pannello



6600 M/245



1 066000245

6600 M/162

assortimento 31 utensili,
con ganci senza pannello

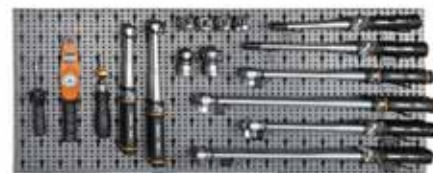

6600 M/162



1 066000162

6600 M/230

assortimento 78 utensili,
con ganci senza pannello



6600 M/230



1 066000230

6600 M/246

assortimento 86 utensili,
con ganci senza pannello



6600 M/246



1 066000246

6600 M/170

assortimento 14 utensili,
con ganci senza pannello



6600 M/170



1 066000170

6600 M/235

assortimento 31 utensili,
con ganci senza pannello



6600 M/235



1 066000235

6600 M/250

assortimento 32 utensili,
con ganci senza pannello

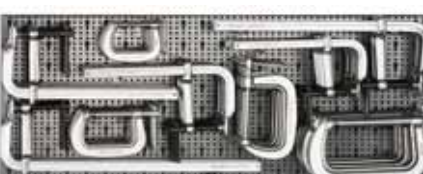

6600 M/250



1 066000250

6600 M/251

assortimento 26 utensili,
con ganci senza pannello



6600 M/251 1 066000251

6600 M/325

assortimento 52 utensili,
con ganci senza pannello



6600 M/325 1 066000325

6600 M/360

assortimento 56 utensili,
con ganci senza pannello



6600 M/360 1 066000360

6600 M/310

assortimento 169 utensili,
con ganci senza pannello



6600 M/310 1 066000310

6600 M/340

assortimento 191 utensili,
con ganci senza pannello

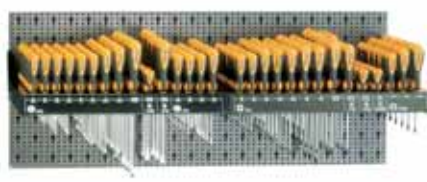

6600 M/340 1 066000340

6600 M/370

assortimento 162 utensili,
con ganci senza pannello

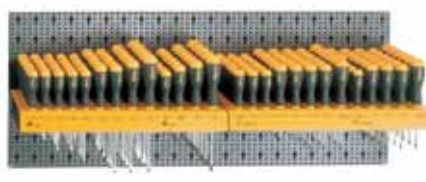

6600 M/370 1 066000370

6600 M/315

assortimento 149 utensili,
con ganci senza pannello

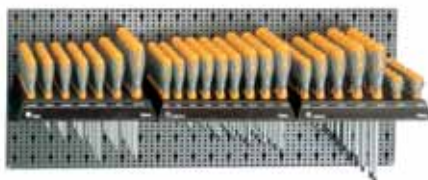

6600 M/315 1 066000315

6600 M/345

assortimento 188 utensili,
con ganci senza pannello



6600 M/345 1 066000345

6600 M/375

assortimento 60 utensili,
con ganci senza pannello



6600 M/375 1 066000375

6600 M/320

assortimento 98 utensili,
con ganci senza pannello

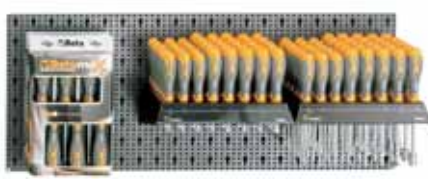

6600 M/320 1 066000320

6600 M/355

assortimento 102 utensili,
con ganci senza pannello

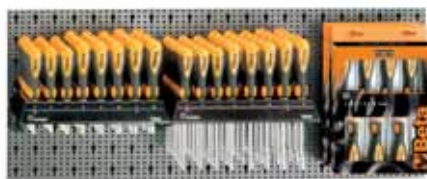

6600 M/355 1 066000355

6600 M/410

assortimento 34 utensili,
con ganci senza pannello



6600 M/410 1 066000410

6600 M/413

assortimento 32 utensili,
con ganci senza pannello



6600 M/413



1 066000413

6600 M/430

assortimento 29 utensili,
con ganci senza pannello



6600 M/430



1 066000430

6600 M/463

assortimento 36 utensili,
con ganci senza pannello



6600 M/463



1 066000463

6600 M/417

assortimento 43 utensili,
con ganci senza pannello



6600 M/417



1 066000417

6600 M/435

assortimento 22 utensili,
con ganci senza pannello



6600 M/435



1 066000435

6600 M/471

assortimento 25 utensili,
con ganci senza pannello



6600 M/471



1 066000471

6600 M/420

assortimento 18 utensili,
con ganci senza pannello



6600 M/420



1 066000420

6600 M/440

assortimento 140 utensili,
con ganci senza pannello

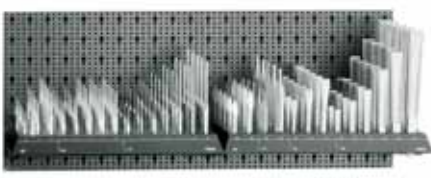

6600 M/440



1 066000440

6600 M/477

assortimento 34 utensili,
con ganci senza pannello



6600 M/477



1 066000477

6600 M/425

assortimento 24 utensili,
con ganci senza pannello



6600 M/425



1 066000425

6600 M/452

assortimento 37 utensili,
con ganci senza pannello

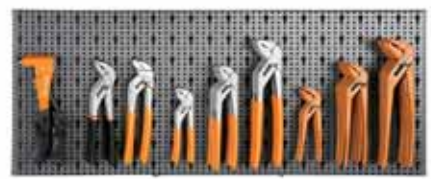

6600 M/452



1 066000452

6600 M/480

assortimento 18 utensili,
con ganci senza pannello



6600 M/480



1 066000480

6600 M/485

assortimento 12 utensili,
con ganci senza pannello



6600 M/485



6600 M/523

assortimento 74 utensili,
con ganci senza pannello



6600 M/523



6600 M/561

assortimento 60 utensili,
con ganci senza pannello



6600 M/561



6600 M/510

assortimento 16 utensili,
con ganci senza pannello



6600 M/510



6600 M/531

assortimento 24 utensili,
con ganci senza pannello



6600 M/531



6600 M/580

assortimento 21 utensili,
con ganci senza pannello



6600 M/580



6600 M/515

assortimento 3 utensili,
con ganci senza pannello



6600 M/515



6600 M/541

assortimento 53 utensili,
con ganci senza pannello



6600 M/541



6600 M/614

assortimento 67 utensili,
con ganci senza pannello



6600 M/614



6600 M/517

assortimento 20 utensili,
con ganci senza pannello



6600 M/517



6600 M/550

assortimento 442 utensili,
con ganci senza pannello



6600 M/550



6600 M/620

assortimento 95 utensili,
con ganci senza pannello



6600 M/620



6600 M/630

assortimento 82 utensili,
con ganci senza pannello



6600 M/630



1 066000630

6600 M/650

assortimento 28 utensili,
con ganci senza pannello



6600 M/650



1 066000650

6600 M/657

assortimento 17 utensili,
con ganci senza pannello



6600 M/657



1 066000657

6600 M/711

assortimento 63 utensili,
con ganci senza pannello



6600 M/711



1 066000711

Beta

6600 M/722

assortimento 7 utensili,
con ganci senza pannello



6600 M/722



1 066000722

6600 M/817

assortimento 99 utensili,
con ganci senza pannello



6600 M/817



1 066000817

6600 M/822

assortimento 39 utensili,
con ganci senza pannello



6600 M/822



1 066000822

6600 M/828

assortimento 49 utensili,
con ganci senza pannello



6600 M/828



1 066000828

Robur

8600 R/10

assortimento 672 accessori per funi,
con ganci senza pannello



8600 R/10



1 086000010

8600 R/111

assortimento 1887 accessori per funi,
con ganci senza pannello



8600 R/111



1 086000111

Beta WORK

8600 R/220

assortimento 53 accessori per funi,
con ganci senza pannello



8600 R/220



1 086000220

8600 R/410

assortimento 585 accessori per funi,
con ganci senza pannello

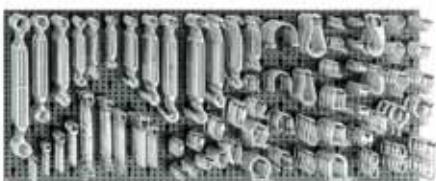

8600 R/410



1 086000410

8600 E/R

assortimento 3197 accessori per funi,
con ganci senza espositore



8600 E/R



1 086000911

6600 E/A10

assortimento 825 utensili,
con ganci senza espositore



6600 E/A10



1 066000903

6600 E/A20

assortimento 701 utensili,
con ganci senza espositore



6600 E/A20



1 066000906

6600 E/A30

assortimento 753 utensili,
con ganci senza espositore



6600 E/A30



1 066000909



6600 E/B10

assortimento 630 utensili,
con ganci senza espositore



6600 E/B10



1 066000910

6600 E/C10

assortimento 312 utensili,
con ganci senza espositore



6600 E/C10



1 066000931

6600 E/D10

assortimento 270 utensili,
con ganci senza espositore



6600 E/D10



1 066000938

6600 E/B30

assortimento 597 utensili,
con ganci senza espositore



6600 E/B30



1 066000920

6600 E/E10

assortimento 128 utensili,
con ganci senza espositore



6600 E/E10



1 066000944



6600 E/G10

assortimento 122 utensili,
con ganci senza espositore



6600 E/G10



1 066000953

6600 E/K20

assortimento 504 utensili,
con ganci senza espositore



6600 E/K20



1 066000957

6600 E/K10

assortimento 610 utensili,
con ganci senza espositore



6600 E/K10



1 066000958

6600 E/P10

assortimento 126 utensili,
con ganci senza espositore



6600 E/P10



1 066000963



Robur

Dal 1930, Robur produce linee di accessori per funi allineandosi alla riconosciuta qualità di Beta Utensili, di cui è complemento produttivo.

Esperienza, organizzazione e tecnologia sono i requisiti di un continuo sviluppo determinato dall'attenzione alle esigenze del mercato.

Dal 1984, Robur ha sede in un moderno stabilimento a Sulmona.

Guida alla lettura

numero articolo

8041EALZ

golfari maschi
zincati

CE



DIN 580:2003

novità 2010

prezzo unitario

misura

numero utensili
nella confezione

Ø mm	mm	WLL kg	
M8	1,25	140	60 080410108
M10	1,5	230	50 080410110
M12	1,75	340	25 080410112
M14	2	480	25 080410114
M16	2	700	1 080410116
M18	2,5	930	1 080410118
M20	2,5	1200	1 080410120
M22	2,5	1450	1 080410122
M24	3	1800	1 080410124

numero codice

CARICHI

WLL: carico massimo di esercizio
(per accessori di sollevamento)

WFL: forza limite di lavoro
(per accessori non destinati al sollevamento)

BF: forza massima raggiunta dall'articolo
durante la prova di trazione statica

LC: tensione di ancoraggio

8001Z

canaule per tenditori
zincate



Ø mm	"	WFL kg		
M5	3/16	115	1	080010105
M6	1/4	160	1	080010106
M8	5/16	300	1	080010108
M10	3/8	470	1	080010110
M11	7/16	580	1	080010111
M12	1/2	690	1	080010112
M14	9/16	940	1	080010114
M16	5/8	1290	1	080010116
M18	11/16	1660	1	080010118
M20	3/4	2130	1	080010120
M22	7/8	2630	1	080010122
M24	1"	3060	1	080010124
M27	1 1/8	4000	1	080010127
M30	1 3/16	4860	1	080010130
M33	1 1/4	6040	1	080010133

8002ZD

anelli per tenditori
Destri - zincati

A richiesta con filetto sinistrorso



Ø mm	"	WFL kg		
M5	3/16	115	200	080020105
M6	1/4	160	150	080020106
M8	5/16	300	100	080020108
M10	3/8	470	100	080020110
M11	7/16	580	1	080020111
M12	1/2	690	50	080020112
M14	9/16	940	1	080020114
M16	5/8	1290	1	080020116
M18	11/16	1660	1	080020118
M20	3/4	2130	1	080020120
M22	7/8	2630	1	080020122
M24	1"	3060	1	080020124
M27	1 1/8	4000	1	080020127
M30	1 3/16	4860	1	080020130
M33	1 1/4	6040	1	080020133

8003ZD

ganci per tenditori
Destri - zincati

A richiesta con filetto sinistrorso



Ø mm	"	WFL kg		
M5	3/16	25	150	080030105
M6	1/4	45	120	080030106
M8	5/16	95	100	080030108
M10	3/8	140	70	080030110
M11	7/16	165	1	080030111
M12	1/2	300	30	080030112
M14	9/16	420	1	080030114
M16	5/8	570	1	080030116

Ø mm	"	WFL kg		
M18	11/16	700	1	080030118
M20	3/4	900	1	080030120
M22	7/8	1100	1	080030122
M24	1"	1300	1	080030124

8005Z

tenditori a due occhi
zincati



Ø mm	"	WFL kg		
M5	3/16	115	400	080050105
M6	1/4	160	300	080050106
M8	5/16	300	200	080050108
M10	3/8	470	100	080050110
M11	7/16	580	80	080050111
M12	1/2	690	60	080050112
M14	9/16	940	35	080050114
M16	5/8	1290	1	080050116
M18	11/16	1660	1	080050118
M20	3/4	2130	1	080050120
M22	7/8	2630	1	080050122
M24	1"	3060	1	080050124
M27	1 1/8	4000	1	080050125
M30	1 3/16	4860	1	080050130
M33	1 1/4	6040	1	080050126

confezioni speciali

Ø mm	"			
M5	3/16	30	300	080050705
M6	1/4	30	300	080050706
M8	5/16	20	300	080050708
M10	3/8	15	90	080050710
M11	7/16	15	60	080050711
M12	1/2	15	60	080050712

8005WZ

tenditori a due occhi
zincati
filettatura Whitworth



Ø w	WFL kg		
1 3/8	6500	1	080050136
1 1/2	7900	1	080050139

8006Z

tenditori ad occhio e gancio
zincati



Ø mm	"	WFL kg		
M5	3/16	25	400	080060105
M6	1/4	45	250	080060106
M8	5/16	95	180	080060108
M10	3/8	140	100	080060110
M11	7/16	165	70	080060111
M12	1/2	300	50	080060112
M14	9/16	420	1	080060114
M16	5/8	570	1	080060116
M18	11/16	700	1	080060118
M20	3/4	900	1	080060120
M22	7/8	1100	1	080060122
M24	1"	1300	1	080060124

confezioni speciali

Ø mm	"			
M5	3/16	30	300	080060705
M6	1/4	30	300	080060706
M8	5/16	20	180	080060708
M10	3/8	15	90	080060710
M11	7/16	15	60	080060711

8007Z

tenditori a due ganci
zincati



Ø mm	"	WFL kg		
M5	3/16	25	300	080070105
M6	1/4	45	220	080070106
M8	5/16	95	160	080070108
M10	3/8	140	80	080070110
M11	7/16	165	60	080070111
M12	1/2	300	40	080070112
M14	9/16	420	1	080070114
M16	5/8	570	1	080070116
M18	11/16	700	1	080070118
M20	3/4	900	1	080070120
M22	7/8	1100	1	080070122
M24	1"	1300	1	080070124

8008N

tenditori a due tronchi
neri



Ø mm	"	WFL kg		
M5	3/16	115	1	080080205
M6	1/4	160	1	080080206
M8	5/16	300	1	080080208
M10	3/8	470	1	080080210
M11	7/16	580	1	080080211
M12	1/2	690	1	080080212
M14	9/16	940	1	080080214
M16	5/8	1290	1	080080216
M18	11/16	1660	1	080080218
M20	3/4	2130	1	080080220
M22	7/8	2630	1	080080222
M24	1"	3060	1	080080224
M27	1 1/8	4000	1	080080227
M30	1 3/16	4860	1	080080230
M33	1 1/4	6040	1	080080233

8008WN

tenditori a due tronchi
neri
filettatura Whitworth



Ø w	WFL kg		
1 3/8	6500	1	080080236
1 1/2	7900	1	080080239

8009Z

tenditori a due forcelle
zincati



Ø mm	"	WFL kg		
M8	5/16	300	1	080090008
M10	3/8	470	1	080090010
M12	1/2	690	1	080090012
M14	9/16	940	1	080090014
M16	5/8	1290	1	080090016
M18	11/16	1660	1	080090018
M20	3/4	2130	1	080090020
M22	7/8	2630	1	080090022
M24	1"	3060	1	080090024
M27	1"1/8	4000	1	080090027
M30	1"3/16	4860	1	080090030

8010Z

tenditori ad occhio e forcella
zincati

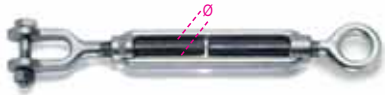

Ø mm	"	WFL kg		
M8	5/16	300	1	080100008
M10	3/8	470	1	080100010
M12	1/2	690	1	080100012
M14	9/16	940	1	080100014
M16	5/8	1290	1	080100016
M18	11/16	1660	1	080100018
M20	3/4	2130	1	080100020
M22	7/8	2630	1	080100022
M24	1"	3060	1	080100024
M27	1"1/8	4000	1	080100027
M30	1"3/16	4860	1	080100030

8105

tenditori a due occhi ad alta resistenza
zincati a caldo

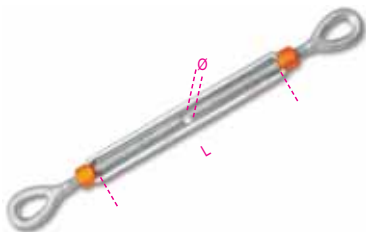

ØxL "	WFL kg		
3/8x6	540	1	081050010
1/2x9	1000	1	081050012
5/8x9	1590	1	081050016
3/4x9	2360	1	081050020
1"x6	4540	1	081050024
1"x12	4540	1	081050025
1"1/4x12	6890	1	081050031

8109

tenditori a due forcelle ad alta resistenza
zincati a caldo

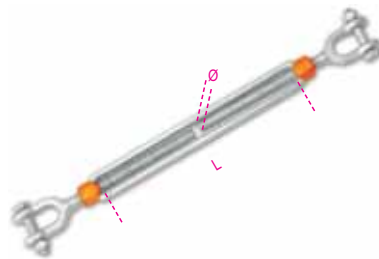

ØxL "	WFL kg		
3/8x6	540	1	081090010
5/8x9	1590	1	081090016
3/4x9	2360	1	081090020
7/8x12	3270	1	081090022
1"x6	4540	1	081090024
1"x12	4540	1	081090025

8016U

morsetti zincati EN 13411-5

CE

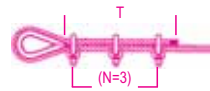

EN 13411-5

Ø mm	"	T	N		
5	3/16	156	3	300	080160605
6,5	1/4	192	3	150	080160606
8	5/16	320	4	70	080160608
10	3/8	320	4	60	080160610
12	1/2	384	4	25	080160612
14	9/16	448	4	15	080160614
16	5/8	512	4	10	080160616
19	3/4	512	4	15	080160619
22	7/8	680	5	10	080160622
26	1"	760	5	15	080160626
30	1"1/8	984	6	5	080160630
34	1"1/4	1080	6	5	080160634
40	1"1/2	1176	6	3	080160640

8016

morsetti in acciaio
zincati

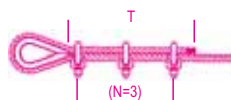

Ø mm	"	T	N		
3	1/8	80	3	500	080160003
5	3/16	110	3	300	080160005
6	1/4	120	3	200	080160006
8	5/16	210	5	150	080160008
10	3/8	240	5	70	080160010
11	7/16	260	5	70	080160011
13	1/2	300	5	40	080160013
14	9/16	295	5	35	080160014
16	5/8	335	5	30	080160016
18	11/16	380	5	30	080160018
20	3/4	540	5	30	080160020

Ø mm	"	T	N		
22	7/8	595	7	25	080160022
26	1"	700	7	40	080160026
30	1"1/8	990	8	1	080160030
34	1"1/4	1155	8	1	080160034
40	1"1/2	1320	8	1	080160040

confezioni speciali

Ø mm	"			
3	1/8	100	1200	080160703
5	3/16	50	600	080160705
6	1/4	50	600	080160706
8	5/16	30	360	080160708
10	3/8	30	240	080160710
11	7/16	25	200	080160711
13	1/2	15	120	080160713

8016FR

morsetti in acciaio
con corpo stampato a freddo
zincati

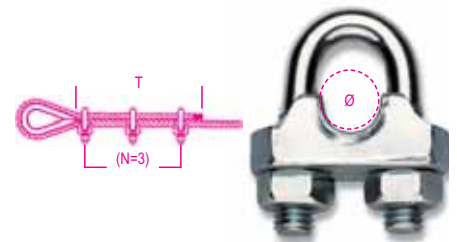

Ø mm	"	T	N		
3	1/8	80	3	500	080160253
5	3/16	110	3	300	080160255
6	1/4	120	3	200	080160256
8	5/16	210	5	150	080160258
10	3/8	240	5	70	080160260
13	1/2	300	5	40	080160263

8317DZ

morsetti duplex
zincati



Ø mm	L mm	L1 mm		
2	30	14	50	083170002
3	35	15	50	083170003
4	40	18	50	083170004
5	50	21	25	083170005
6	60	25	20	083170006
8	76	33	10	083170008
10	95	37	10	083170010

Robur



8317SZ

morsetti simplex
zincati



Ø mm	L mm	L1 mm		
2	15	14	100	083170102
3	18	16	100	083170103
4	20	19	100	083170104
5	24	23	50	083170105
6	30	27	30	083170106
8	36	34	20	083170108
10	42	37	10	083170110

8020

radance tipo leggero
zincate

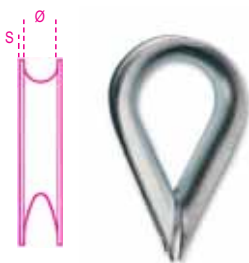

I prezzi indicati sono relativi a 10 pezzi

Ø mm	S mm		
2-3	0,6	350	080200103
4	0,7	300	080200104
5	0,8	300	080200105
6	1,0	200	080200106
8	1,2	180	080200108
10	1,5	120	080200110
12	1,8	160	080200112
14	2,0	100	080200114
16	2,0	150	080200116
18	2,5	100	080200118
20	3,0	70	080200120
22	3,0	60	080200122
25	3,5	40	080200125
28	4,0	10	080200128

confezioni speciali

Ø mm	S mm			
2-3	0,6	150	3150	080200703
4	0,7	150	3150	080200704
5	0,8	100	1500	080200705
6	1,0	100	1500	080200706
8	1,2	50	750	080200708
10	1,5	30	450	080200710

8021

radance tipo pesante
zincate

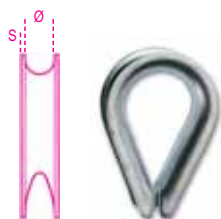

Ø mm	S mm		
5	1,7	120	080210005
6	1,8	100	080210006
8	2,5	100	080210008

Ø mm	S mm		
10	2,5	80	080210010
12	2,5	100	080210012
14	2,7	70	080210014
16	3,0	50	080210016
18	3,5	70	080210018
20	4,0	60	080210020
22	4,0	50	080210022
24	4,0	40	080210024
26	4,0	35	080210026
28	5,0	1	080210028
30	5,0	1	080210030
32	5,5	1	080210032
35	6,0	1	080210035
40	6,0	1	080210040

8025

grilli diritti tipo largo
forgiati
zincati



Ø mm	"	WLL kg		
5	3/16	70	250	080250005
6	1/4	100	250	080250006
8	5/16	250	150	080250008
10	3/8	400	180	080250010
11	7/16	500	130	080250011
12	1/2	600	100	080250012
14	9/16	800	70	080250014
16	5/8	1000	50	080250016
18	11/16	1300	35	080250018
20	3/4	1600	30	080250020
22	7/8	2000	20	080250022
25	1"	2800	15	080250025

confezioni speciali

Ø mm	"			
5	3/16	25	525	080250705
6	1/4	25	525	080250706
8	5/16	25	250	080250708
10	3/8	15	150	080250710
11	7/16	12	120	080250711
12	1/2	12	72	080250712

8026A

grilli diritti, tipo A
forgiati
zincati



UNI 1947

Ø mm	"	WLL kg		
12	1/2	630	100	080260012
14	9/16	800	90	080260014
16	5/8	1000	60	080260016
18	11/16	1300	40	080260018
20	3/4	1600	35	080260020
22	7/8	2000	20	080260022
25	1"	2500	15	080260025
28	1.1/8	3150	1	080260028

Ø mm	"	WLL kg		
32	1.1/4	4000	1	080260032
36	1.3/8	5000	1	080260036
40	1.9/16	6300	1	080260040
42	1.5/8	8000	1	080260042
45	1.3/4	10000	1	080260045
50	2"	12500	1	080260050

8028

grilli a lira forgiati zincati



Ø mm	"	WLL kg		
5	3/16	80	1	080280105
6	1/4	100	1	080280106
8	5/16	200	1	080280108
10	3/8	300	1	080280110
11	7/16	400	1	080280111
12	1/2	500	1	080280112
14	9/16	600	1	080280114
16	5/8	800	1	080280116
20	3/4	1100	1	080280120
22	7/8	1500	1	080280122
25	1"	2000	1	080280125
28	1.1/8	2600	1	080280128
32	1.1/4	3200	1	080280132
38	1.1/2	4500	1	080280138

8029

grilli a lira ad alta resistenza
in acciaio legato
zincati

CE

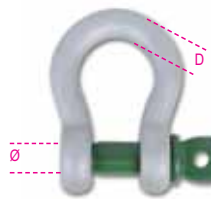

*EN 13889

Ø mm	D "	WLL kg		
* 11	3/8	1000	1	080290011
* 13	7/16	1500	1	080290013
* 16	1/2	2000	1	080290016
* 19	5/8	3250	1	080290019
* 22	3/4	4750	1	080290022
* 25	7/8	6500	1	080290025
* 28	1"	8500	1	080290028
* 32	1.1/8	9500	1	080290032
* 35	1.1/4	12000	1	080290035
* 38	1.3/8	13500	1	080290038
* 42	1.1/2	17000	1	080290042
* 50	1.3/4	25000	1	080290050
57	2"	35000	1	080290057
60	2.1/4	42500	1	080290065
65	2.1/2	55000	1	080290070

Robur



8030

grilli a lira ad alta resistenza
con perno quadro in acciaio legato
zincati

CE

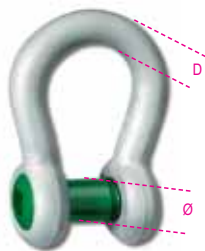

Ø mm	D "	WLL kg		
16	1/2	2000	1	080300016
19	5/8	3250	1	080300019
22	3/4	4750	1	080300022
25	7/8	6500	1	080300025

8031

grilli a lira ad alta resistenza
con dado a coppiglia

CE

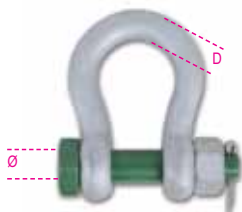

*EN 13889

Ø mm	D "	WLL kg		
* 11	3/8	1000	1	080310011
* 16	1/2	2000	1	080310016
* 19	5/8	3250	1	080310019
* 22	3/4	4750	1	080310022
* 25	7/8	6500	1	080310025
* 28	1"	8500	1	080310028
* 32	1.1/8	9500	1	080310032
* 35	1.1/4	12000	1	080310035
* 38	1.3/8	13500	1	080310038
* 42	1.1/2	17000	1	080310042
* 50	1.3/4	25000	1	080310050
70	2.1/2	55000	1	080310070

8040EZ

golfari maschi
zincati

CE



DIN 580:1972

Ø mm	WLL kg		
M6	75	60	080400406
M8	140	60	080400408
M10	230	50	080400410
M12	340	25	080400412
M14	480	25	080400414
M16	700	1	080400416
M18	930	1	080400418

Ø mm	WLL kg		
M20	1200	1	080400420
M22	1450	1	080400422
M24	1800	1	080400424
M27	2400	1	080400427
M30	3200	1	080400430
M36	4600	1	080400436
M36F	4600	1	080400437
M42	6300	1	080400442
M42F	6300	1	080400443
M48	8600	1	080400448
M48F	8600	1	080400449
M56	11500	1	080400456
M56F	11500	1	080400457
M64	16000	1	080400464
M64F	16000	1	080400465

8041EALZ

golfari maschi
zincati

CE



DIN 580:2003

Ø mm	WLL kg		
M8	140	60	080410108
M10	230	50	080410110
M12	340	25	080410112
M14	480	25	080410114
M16	700	1	080410116
M18	930	1	080410118
M20	1200	1	080410120
M22	1450	1	080410122
M24	1800	1	080410124

8040EN

golfari maschi
neri

CE



DIN 580:1972

Ø mm	WLL kg		
M6	75	60	080400306
M8	140	60	080400308
M10	230	50	080400310
M12	340	25	080400312
M14	480	25	080400314
M16	700	1	080400316
M18	930	1	080400318
M20	1200	1	080400320
M22	1450	1	080400322
M24	1800	1	080400324
M27	2400	1	080400327
M30	3200	1	080400330
M36	4600	1	080400336
M36F	4600	1	080400337

8041EALN

golfari maschi
neri

CE



DIN 580:2003

Ø mm	WLL kg		
M8	140	60	080410008
M10	230	50	080410010
M12	340	25	080410012
M14	480	25	080410014
M16	700	1	080410016
M18	930	1	080410018
M20	1200	1	080410020
M22	1450	1	080410022
M24	1800	1	080410024

8042EZ

golfari femmina
zincati

CE



DIN 582:1971

Ø mm	WLL kg		
M6	75	60	080420406
M8	140	60	080420408
M10	230	50	080420410
M12	340	30	080420412
M14	480	30	080420414
M16	700	1	080420416
M18	930	1	080420418
M20	1200	1	080420420
M22	1450	1	080420422
M24	1800	1	080420424
M27	2400	1	080420427
M30	3200	1	080420430
M36	4600	1	080420436
M36F	4600	1	080420437
M42	6300	1	080420442
M42F	6300	1	080420443
M48	8600	1	080420448
M48F	8600	1	080420449

8043EALZ

golfari femmina
zincati

CE



DIN 582:2003

Ø mm	W mm	WLL kg		
M8	1,25	140	60	080430108
M10	1,5	230	50	080430110
M12	1,75	340	30	080430112
M14	2	480	30	080430114
M16	2	700	1	080430116
M18	2,5	930	1	080430118
M20	2,5	1200	1	080430120
M22	2,5	1450	1	080430122
M24	3	1800	1	080430124

8043EALN

golfari femmina
neri

CE



DIN 582:2003

Ø mm	W mm	WLL kg		
M8	1,25	140	60	080430008
M10	1,5	230	50	080430010
M12	1,75	340	30	080430012
M14	2	480	30	080430014
M16	2	700	1	080430016
M18	2,5	930	1	080430018
M20	2,5	1200	1	080430020
M22	2,5	1450	1	080430022
M24	3	1800	1	080430024

8042EN

golfari femmina
neri



DIN 582:1971

Ø mm	W mm	WLL kg		
M6	1	75	60	080420306
M8	1,25	140	60	080420308
M10	1,5	230	50	080420310
M12	1,75	340	30	080420312
M14	2	480	30	080420314
M16	2	700	1	080420316
M18	2,5	930	1	080420318
M20	2,5	1200	1	080420320
M22	2,5	1450	1	080420322
M24	3	1800	1	080420324
M27	3	2400	1	080420327
M30	3,5	3200	1	080420330
M36	4	4600	1	080420336
M36F	3	4600	1	080420337
M42	4,5	6300	1	080420342
M42F	3	6300	1	080420343
M48	5	8600	1	080420348
M48F	3	8600	1	080420349

8044

golfari femmina
neri



UNI 2948

Ø mm	W mm	WLL kg		
M8	1,25	80	1	080440008
M10	1,5	160	1	080440010
M12	1,75	250	1	080440012
M14	2	330	1	080440014
M16	2	400	1	080440016
M18	2,5	500	1	080440018
M20	2,5	630	1	080440020
M22	2,5	780	1	080440022
M24	3	1000	1	080440024
M27	3	1000	1	080440027
M30	3,5	1600	1	080440030
M36	3	2500	1	080440036
M42	3	3750	1	080440042

8048

tiranti ad occhio
destr
neri



UNI 6058

ØxL mm	F mm		
M8x50	6	1	080480108
M8x65	6	1	080480109
M10x80	8	1	080480110
M10x130	8	1	080480111
M12x95	10	1	080480112
M12x125	10	1	080480113
M14x110	12	1	080480114
M16x130	14	1	080480116
M18x150	16	1	080480118

ØxL mm	F mm		
M20x160	18	1	080480120
M22x180	18	1	080480122
M24x200	20	1	080480124
M27x220	22	1	080480127

8053S

ganci di sollevamento tipo americano
in acciaio al carbonio
bonificati

CE



EN 1677-5
GRADO 4

WLL kg	C mm	F mm		
800	20	19	1	080530107
1000	22	25	1	080530110
1600	23	28	1	080530115
2000	27	32	1	080530120
3200	32	40	1	080530130
5000	41	51	1	080530150
7500	53	64	1	080530175
10000	58	70	1	080530200

8055S

ganci di sollevamento tipo americano
ad alta resistenza
in acciaio legato, bonificati

CE



EN 1677-2
GRADO 8

WLL kg	C mm	F mm		
1250	20	19	1	080550110
1600	22	25	1	080550115
2500	23	28	1	080550120
3200	27	32	1	080550130
5400	32	40	1	080550145
8000	41	51	1	080550170
11500	53	64	1	080550215
16000	58	70	1	080550260
22000	78	90	1	080550320

Robur

8057

ganci self-locking ad occhio
in acciaio legato
bonificati

CE



EN 1677-3
GRADO 8

WLL kg	C mm	F mm	
2000	33	25	1 080570020
3150	44	32	1 080570032
5300	54	40	1 080570053

8058

ganci self-locking Clevis
in acciaio legato
bonificati

CE



EN 1677-3
GRADO 8

WLL kg	C mm	F mm	
2000	33	10	1 080580020
3150	44	13	1 080580032
5300	54	16	1 080580053

8060

ganci Clevis per catena
in acciaio legato
bonificati

CE



EN 1677-2
GRADO 8

WLL kg	C mm	F mm	
2000	25	9,5	1 080600020
3150	33	12,0	1 080600032
5300	43	15,5	1 080600053

8061

ganci accorciatori ad occhio
in acciaio legato
bonificati

CE



EN 1677-1
GRADO 8

WLL kg	C mm	F mm	
2000	10	15	1 080610020
3150	13	20	1 080610032
5300	16	25	1 080610053

8062

ganci scorsoi
in acciaio legato



WLL kg	C mm	F mm	
1500	19	10-13	1 080620013
2000	21	16	1 080620016
3000	26	18	1 080620018
5000	34	22-25	1 080620025

8064S

ganci girevoli
in acciaio al carbonio
bonificati

CE

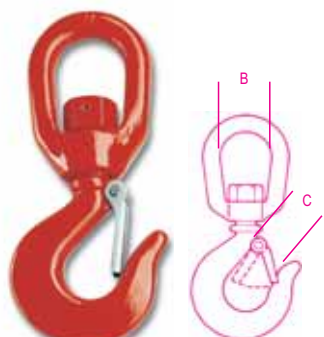

EN 1677-5
GRADO 4

WLL kg	B mm	C mm	
800	31	20	1 080640107
1000	40	22	1 080640110
1600	47	23	1 080640115
2000	47	27	1 080640120
3200	64	35	1 080640130
5000	77	43	1 080640150
7500	90	53	1 080640175
10000	96	58	1 080640199

8065SC

ganci girevoli sotto carico, con cuscinetto
in acciaio al carbonio

CE

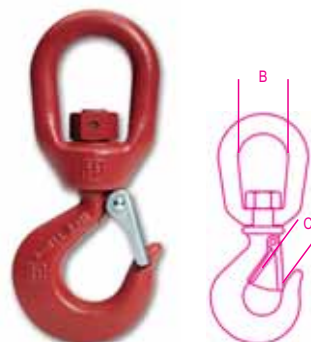

EN 1677-5
GRADO 4

WLL kg	B mm	C mm	
800	31	20	1 080650107
1000	40	22	1 080650110
1600	47	23	1 080650115
2000	47	27	1 080650120
3200	64	35	1 080650130
5000	77	43	1 080650150

8050D

kit sicure di ricambio per ganci

8050D1 8053S-8064S-8065SC/800 8055/1250	1 080500945
8050D2 8053S-8064S-8065SC/1000 8055S/1600	1 080500946
8050D3 8053S-8064S-8065SC/1600-2000 8055/2500-3200	1 080500947
8050D4 8053S-8064S-8065SC/3200 8055S/5400	1 080500948
8050D5 8053S-8064S-8065SC/5000 8055S/8000	1 080500949
8050D6 8064S/7500 8055S/11500	1 080500950
8050D7 8060/2000	1 080500951
8050D8 8060/3150	1 080500952
8050D9 8060/5300	1 080500953
8050D10 8062/1500	1 080500954
8050D11 8062/2000	1 080500955
8050D12 8062/3000	1 080500956
8050D13 8062/5000	1 080500957
8050D14 8068/500-1000	1 080500958
8050D15 8068/2000	1 080500959
8050D16 8068/3000-4000	1 080500960
8050D17 8068/6000-8000	1 080500961
8050D18 8069/1000	1 080500962
8050D19 8069/2000-3000	1 080500963
8050D20 8069/4000-5000-6000	1 080500964
8050D21 8069/8000-10000-18000	1 080500965

8050D22	1	080500966
8053S-8064S/10000		
8055S/16000		
8050D23	1	080500967
8055S/22000		

8068

ganci a saldare ad "U"
in acciaio legato



WLL kg	C mm	L mm		
500	20	95	1	080680005
1000	23	105	1	080680010
2000	28	123	1	080680020
3000	31	145	1	080680030
4000	31	152	1	080680040
6000	43	205	1	080680060
8000	42	216	1	080680080

8069

ganci a saldare a "C"
in acciaio legato



WLL kg	C mm	L mm		
1000	21	105	1	080690010
2000	25	130	1	080690020
3000	25	133	1	080690030
4000	38	177	1	080690040
5000	40	185	1	080690050
6000	40	198	1	080690060
8000	45	250	1	080690080
10000	50	262	1	080690100
18000	50	290	1	080690180

8074

moschettoni
zincati



DxL mm	A mm	WLL kg		
4x40	6	20	100	080740040
5x50	7	30	100	080740050
6x60	8	40	100	080740060
7x70	9	60	50	080740070
8x80	11	75	50	080740080
9x90	12	100	25	080740090
10x100	13	120	25	080740100
11x120	16	140	20	080740101
12x140	22	140	15	080740102
13x160	24	200	10	080740103

8080

maglie rapide di giunzione
zincate

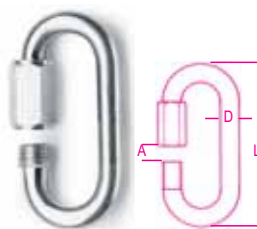

DxL mm	A mm	WLL kg		
3,5x36	5	20	100	080800003
4x40	6	30	100	080800004
5x49	6	50	100	080800005
6x57	8	60	100	080800006
7x66	8	100	50	080800007
8x74	11	140	50	080800008
9x80	11	160	25	080800009
10x89	11	220	25	080800010
12x105	15	300	20	080800012

8085

campanelle
in acciaio legato
bonificate

Il carico di lavoro WLL è relativo all'utilizzo con imbragature ad 1 braccio.

CE



EN 1677-4
GRADO 8

WLL kg	Ø mm		
1500	7	1	080850016
2000	8	1	080850020
3150	10	1	080850032
5300	13	1	080850054
8000	16	1	080850080

8086

campanelle triple
in acciaio legato
bonificate

Il carico di lavoro WLL è relativo all'utilizzo con imbragature a 3 o 4 bracci e angolo β inferiore a 45°

CE



EN 1677-4
GRADO 8

WLL kg	Ø mm		
2360*	6	1	080860021
4250	8	1	080860042
6700	10	1	080860067
11200	13	1	080860100

* Abbinata a catena Ø 7 mm, WLL= 3150 kg.

8090

maglie di giunzione
in acciaio legato
bonificate

CE



EN 1677-1
GRADO 8

WLL kg	Ø mm		
2000	7-8	1	080900020
3150	10	1	080900032
5300	13	1	080900053

8100

catene - grado 8
in acciaio legato
bonificate, nere

CE

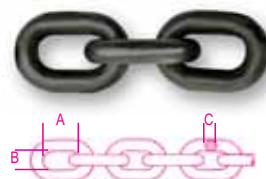

EN 818-2
GRADO 8

WLL kg	A mm	B mm	C mm		
1500	21	11,0	7	1	081000016
2000	24	12,0	8	1	081000020
3150	30	14,5	10	1	081000032
5300	39	20,0	13	1	081000053

8114

tornichetti tipo Marche
zincati

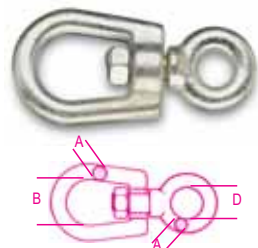

A mm	WLL kg	B mm	D mm		
8	250	30	16	1	081140008
10	300	38	18	1	081140010
12	650	42	20	1	081140012
14	820	48	22	1	081140014
16	1000	57	24	1	081140016
18	1600	64	26	1	081140018
20	2000	72	30	1	081140020
22	2500	80	34	1	081140022

8116

tornichetti tipo Sicilia
zincati

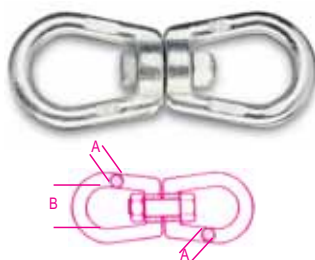

A mm	WFL kg	B mm		
8	250	30	1	081160008
10	300	38	1	081160010
12	650	42	1	081160012
14	820	48	1	081160014
16	1000	57	1	081160016
18	1600	64	1	081160018
20	2000	72	1	081160020
22	2500	80	1	081160022

8302

viti ad occhio per tasselli
filettatura destra
zincate



Ø mm	E mm	F mm		
M5	48	8	200	083020005
M6	55	10	150	083020006
M8	60	12	100	083020008
M10	73	14	100	083020010
M12	90	17	50	083020012

8303

ganci per tasselli
filettatura destra
zincati

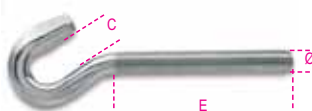

Ø mm	C mm	E mm		
M5	6,0	48	150	083030005
M6	8,0	55	120	083030006
M8	10,0	60	100	083030008
M10	12,5	73	70	083030010
M12	16,0	90	30	083030012

8345Z

golfari per ponteggi
zincati



Ø mm	E mm	WFL kg		
M10	50	1300	1	083450110
M12	50	1400	1	083450112

8346Z

golfare per ponteggi
zincato

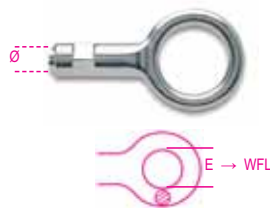

Ø mm	E mm	WFL kg		
M12	50	1600	1	083460112

8381SL

collari per sostegno tubazioni
serie leggera
zincati

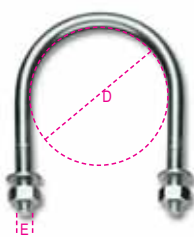

D mm	D gas	E mm		
11	1/8"	M6	250	083810201
14	1/4"	M6	250	083810202
18	3/8"	M6	250	083810203
22	1/2"	M6	250	083810204
27	3/4"	M6	250	083810205
34	1"	M6	250	083810206
43	1"1/4	M6	250	083810207
49	1"1/2	M8	200	083810208
61	2"	M8	200	083810209
77	2"1/2	M8	100	083810210
89	3"	M8	100	083810211
102	3"1/2	M8	100	083810212
115	4"	M8	100	083810213

8381SP

collari per sostegno tubazioni
serie pesante
zincati

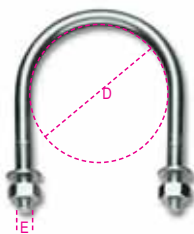

D mm	D gas	E mm		
22	1/2"	M8	200	083810301
27	3/4"	M8	200	083810302
34	1"	M8	200	083810303
43	1"1/4	M8	200	083810304
49	1"1/2	M10	100	083810305
61	2"	M10	100	083810306
77	2"1/2	M10	100	083810307
89	3"	M10	50	083810308
102	3"1/2	M12	50	083810309
115	4"	M12	50	083810310

8099/1

pendenti di catena ad 1 braccio
in valigetta

CE



UNI EN 818-4

D mm	L m	WLL ton		
7	1	1,5	1	080990001
7	2	1,5	1	080990002
7	4	1,5	1	080990004
8	1	2	1	080990101
8	2	2	1	080990102
8	4	2	1	080990104
10	1	3,15	1	080990201
10	2	3,15	1	080990202
10	4	3,15	1	080990204
13	1	5,3	1	080990301
13	2	5,3	1	080990302
13	4	5,3	1	080990304

8099/2

pendenti di catena a 2 bracci
in valigetta

CE



UNI EN 818-4

D mm	L m	WLL ton		
7	1	2,12	1	080990021
7	2	2,12	1	080990022
7	4	2,12	1	080990024
8	1	2,8	1	080990121
8	2	2,8	1	080990122
8	4	2,8	1	080990124
10	1	4,25	1	080990221
10	2	4,25	1	080990222
10	4	4,25	1	080990224
13	1	7,5	1	080990321
13	2	7,5	1	080990322

WLL Ton

UNI EN 818

D mm			
	$0^\circ < \beta \leq 45^\circ$	$45^\circ < \beta \leq 60^\circ$	
7	1,5	2,12	1,5
8	2	2,8	2
10	3,15	4,25	3,15
13	5,3	7,5	5,3

D mm		
	$0^\circ < \beta \leq 45^\circ$	$45^\circ < \beta \leq 60^\circ$
7	3,15	2,24
8	4,25	3
10	6,7	4,75
13	11,2	8

8098/K1

kit pendenti di catena ad 1 braccio
in valigetta

CE



WLL = 1,5 ton

8098/K1-7 1 080980007

	n.	
8058	2000 kg	1
8061	2000 kg	1
8085	1500 kg	1
8090	2000 kg	1

WLL = 2,0 ton

8098/K1-8 1 080980008

	n.	
8058	2000 kg	1
8061	2000 kg	1
8085	2000 kg	1
8090	2000 kg	1

WLL = 3,15 ton

8098/K1-10 1 080980010

	n.	
8058	3150 kg	1
8061	3150 kg	1
8085	3150 kg	1
8090	3150 kg	1

WLL = 5,3 ton

8098/K1-13 1 080980013

	n.	
8058	5300 kg	1
8061	5300 kg	1
8085	5300 kg	1
8090	5300 kg	1

8098/K2

kit pendenti di catena a 2 bracci
in valigetta



WLL = 2,12 ton

8098/K2-7 1 080980027

	n.	
8058	2000 kg	2
8061	2000 kg	2
8085	3150 kg	1
8090	2000 kg	2

WLL = 2,8 ton

8098/K2-8 1 080980028

	n.	
8058	2000 kg	2
8061	2000 kg	2
8085	3150 kg	1
8090	2000 kg	2

WLL = 4,25 ton

8098/K2-10 1 080980030

	n.	
8058	3150 kg	2
8061	3150 kg	2
8085	5300 kg	1
8090	3150 kg	2

WLL = 7,5 ton

8098/K2-13 1 080980033

	n.	
8058	5300 kg	2
8061	5300 kg	2
8085	8000 kg	1
8090	5300 kg	2

8150

fasce di sollevamento

CE

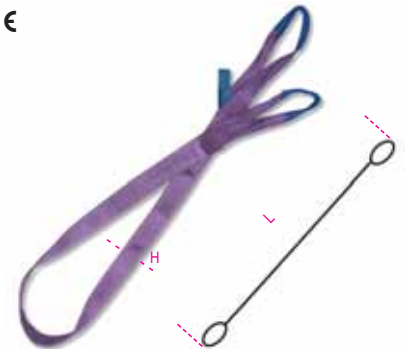

UNI EN 1492-1

L m	H mm	WLL ton		
2	30	1	1	081500020
3	30	1	1	081500030
4	30	1	1	081500040
5	30	1	1	081500050
6	30	1	1	081500060

8153

fasce di sollevamento

CE

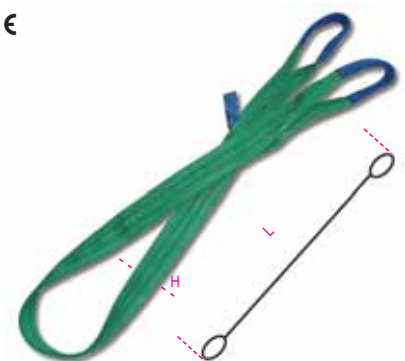

UNI EN 1492-1

L m	H mm	WLL ton		
2	60	2	1	081530020
3	60	2	1	081530030
4	60	2	1	081530040
5	60	2	1	081530050
6	60	2	1	081530060

Robur



8156

fasce di sollevamento

CE

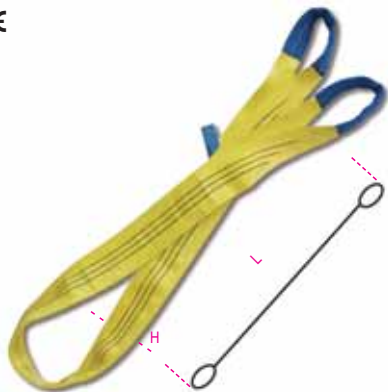

UNI EN 1492-1

L m	H mm	WLL ton		
2	90	3	1	081560020
3	90	3	1	081560030
4	90	3	1	081560040
5	90	3	1	081560050
6	90	3	1	081560060

8157

fasce di sollevamento

CE



UNI EN 1492-1

L m	H mm	WLL ton		
2	120	4	1	081570020
3	120	4	1	081570030
4	120	4	1	081570040
5	120	4	1	081570050
6	120	4	1	081570060

8158

fasce di sollevamento

CE



UNI EN 1492-1

L m	H mm	WLL ton		
2	150	5	1	081580020
3	150	5	1	081580030
4	150	5	1	081580040
5	150	5	1	081580050
6	150	5	1	081580060

8170

funi tonde ad anello

CE



UNI EN 1492-2

L m	WLL ton		
1	1	1	081700020
1,5	1	1	081700030
2	1	1	081700040

8173

funi tonde ad anello

CE



UNI EN 1492-2

L m	WLL ton		
1	2	1	081730020
1,5	2	1	081730030
2	2	1	081730040

8176

funi tonde ad anello

CE



UNI EN 1492-2

L m	WLL ton		
1	3	1	081760020
1,5	3	1	081760030
2	3	1	081760040
3	3	1	081760060

8177

funi tonde ad anello

CE



UNI EN 1492-2

L m	WLL ton		
1	4	1	081770020
1,5	4	1	081770030
2	4	1	081770040
3	4	1	081770060

8178

funi tonde ad anello

CE

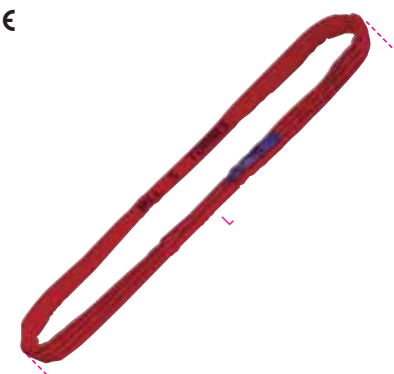

UNI EN 1492-2

L m	WLL ton		
1	5	1	081780020
1,5	5	1	081780030
2	5	1	081780040
3	5	1	081780060

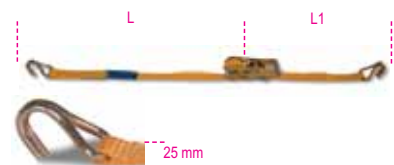
8180sistemi di ancoraggio:
cricchetto tenditore, nastro PES,
ganci a uncino

EN 12195

L mm	L1 mm		
3700	300	1	081800004
5700	300	1	081800006
7700	300	1	081800008

LC = 750 kg

8181

sistemi di ancoraggio:
cricchetto tenditore, nastro PES,
ganci a uncino

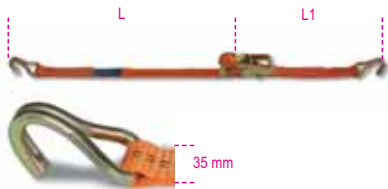

EN 12195

L mm	L1 mm		
3700	300	1	081810004
5700	300	1	081810006
7700	300	1	081810008

LC = 1000 kg

8182

sistemi di ancoraggio:
cricchetto tenditore, nastro PES,
ganci a uncino

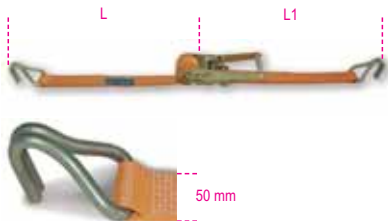

EN 12195

L mm	L1 mm		
8000	500	1	081820085
10000	500	1	081820105

LC = 2000 kg

8182S

sistemi di ancoraggio:
cricchetto tenditore, nastro PES,
ganci sponda

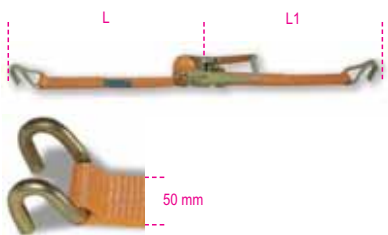

EN 12195

L mm	L1 mm		
8000	500	1	081820285
10000	500	1	081820305

LC = 2000 kg

8185

sistemi di legatura ad anello:
cricchetto tenditore, nastro PES



L mm			
5000	1	081850005	
8000	1	081850008	

LC = 750 kg

8186

sistemi di legatura ad anello:
cricchetto tenditore, nastro PES



L mm			
5000	1	081860005	
8000	1	081860008	

LC = 1000 kg

8187

sistemi di legatura ad anello:
cricchetto tenditore, nastro PES



L mm			
5000	1	081870005	
8000	1	081870008	

LC = 2000 kg

Robur

8188MC

sistemi di legatura ad anello:
fibbia di serraggio, nastro PPH



1500
2500
5000

L mm			
* 1500	2	081880015	
* 2500	2	081880025	
5000	1	081880050	

* I prezzi indicati sono relativi a 2 pezzi

8188MN

sistemi di legatura ad anello:
cricchetto tenditore, nastro PPH



L mm			
5000	1	081880125	

LC = 500 kg

Robur

8018E

morsetto
zincato
disponibile a richiesta



ENEL 2632A

Ø mm	A mm	L mm		
4÷6	M6	34	100	080180001

8018T

morsetto
zincato
disponibile a richiesta



TELECOM 02076-8

Ø mm	A mm	L mm		
8÷10	M8	42	200	080180003

8027

grillo
zincato a fuoco
disponibile a richiesta



TELECOM
04327-3

Ø mm				
M20			1	080270020

Robur INOX

8205

tenditori
a due occhi

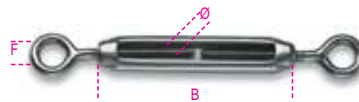

AISI 316

Ø mm	B mm	F mm		
M5	70	9	1	082050005
M6	90	11	1	082050006
M8	120	13	1	082050008
M10	150	16	1	082050010
M12	200	20	1	082050012
M16	247	24	1	082050016
M20	305	28	1	082050020

8206

tenditori
ad occhio e gancio

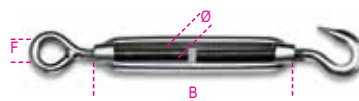

AISI 316

Ø mm	B mm	F mm		
M5	70	9	1	082060005
M6	90	11	1	082060006
M8	120	13	1	082060008
M10	150	16	1	082060010
M12	200	20	1	082060012
M16	247	24	1	082060016
M20	305	28	1	082060020

8207

tenditori
a due ganci

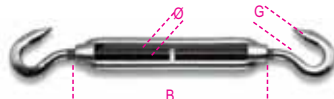

AISI 316

Ø mm	B mm	G mm		
M5	70	7	1	082070005
M6	90	9	1	082070006
M8	120	11	1	082070008
M10	150	12	1	082070010
M12	200	14	1	082070012
M16	247	18	1	082070016
M20	305	20	1	082070020

8209

tenditori a tubo
a due forcelle

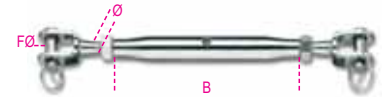

AISI 316

Ø mm	B mm	FØ mm		
M5	80	5	1	082090005
M6	90	5	1	082090006
M8	110	7	1	082090008
M10	121	9	1	082090010
M12	154	12	1	082090012

8216

morsetti
tipo leggero



AISI 316

F mm	A mm	L mm		
2	M3	21	1	082160002
3	M3	21	1	082160003
4	M4	23	1	082160004
5	M5	25	1	082160005
6	M6	32	1	082160006
8	M6	35	1	082160008
10	M8	44	1	082160010
13	M10	55	1	082160013
16	M10	68	1	082160016

8220

radance



AISI 316

F mm	C mm		
2	7	1	082200020
3	10	1	082200030
4	11	1	082200040
5	13	1	082200050
6	14	1	082200060
8	18	1	082200080
10	23	1	082200100
12	27	1	082200120

8225

grilli dritti



AISI 316

Ø mm	C mm	
4	8	1 082250004
5	10	1 082250005
6	12	1 082250006
8	16	1 082250008
10	20	1 082250010
12	24	1 082250012
16	32	1 082250016
19	37	1 082250019

8227

grilli dritti lunghi



AISI 316

Ø mm	C mm	
4	9	1 082270004
5	11	1 082270005
6	13	1 082270006
8	17	1 082270008
10	19	1 082270010
12	26	1 082270012

8228

grilli a lira



AISI 316

Ø mm	C mm	
4	8	1 082280004
5	10	1 082280005
6	12	1 082280006
8	16	1 082280008
10	20	1 082280010
12	26	1 082280013
16	32	1 082280016
19	38	1 082280019

8230

grilli ritorti



AISI 316

Ø mm	C mm	
4	9	1 082300004
5	11	1 082300005
6	12	1 082300006
8	16	1 082300008
10	21	1 082300010
12	24	1 082300012

8240

golfari maschi



AISI 316

Ø mm	F mm	
M6	16	1 082400006
M8	20	1 082400008
M10	25	1 082400010
M12	30	1 082400012

8242

golfari femmina



AISI 316

Ø mm	F mm	
M6	16	1 082420006
M8	19	1 082420008
M10	25	1 082420010
M12	30	1 082420012

8249vite ad occhio per tasselli
filettatura destra

AISI 316

Ø mm	E mm	F mm	
M5	39	9	1 082490005
M6	51	11	1 082490006
M8	63	13	1 082490008
M10	74	16	1 082490010
M12	117	20	1 082490012

8250

ganci con sicura



AISI 316

L mm	A mm	
50	6	1 082500050
70	10	1 082500070
100	13	1 082500100

8270

girelli a due forcelle



AISI 316

Ø mm	C mm	L mm	
6	12	49	1 082700006
8	16	71	1 082700008
10	20	89	1 082700010
13	26	115	1 082700013
16	32	140	1 082700016
19	36	172	1 082700019



8272

girelli a due occhi

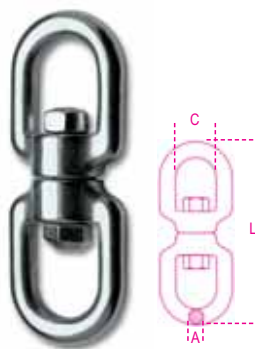

AISI 316

A mm	C mm	L mm		
5	13	59	1	082720005
6	15	65	1	082720006
8	20	90	1	082720008
10	24	115	1	082720010
13	32	152	1	082720013
16	39	188	1	082720016
19	41	230	1	082720019

8274

moschettoni

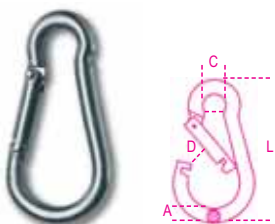

AISI 316

AxL mm	C mm	D mm		
5x50	8	8	1	082740005
6x60	9	9	1	082740006
7x70	11	9	1	082740007
8x80	12	10	1	082740008
10x100	15	12	1	082740010
11x120	18	16	1	082740011
12x140	23	25	1	082740012
13x160	23	30	1	082740013

8280

maglie rapide di giunzione

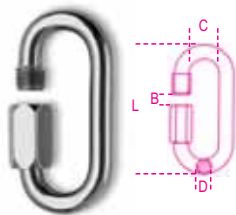

AISI 316

DxL mm	B mm	C mm		
3,5x36	4,0	8,5	1	082800003
4x40	5,5	11,5	1	082800004
5x49	6,5	13,0	1	082800005
6x57	7,5	14,5	1	082800006
7x66	8,5	16,0	1	082800007
8x74	10,0	17,5	1	082800008
10x89	12,0	20,5	1	082800010
12x105	15,0	23,5	1	082800012

8282

ganci a "S"

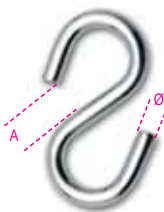

AISI 316

Ø mm	A mm		
3	5	1	082820103
4	6	1	082820104
5	7	1	082820105
6	9	1	082820106
8	10	1	082820108

8285

terminali a forcella

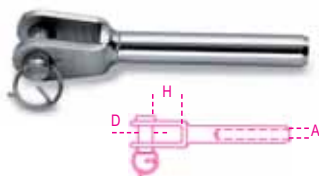

AISI 316

A mm	D mm	H mm		
3	5	9	1	082850003
4	6	9	1	082850004
5	8	11	1	082850005
6	9	13	1	082850006
8	12	22	1	082850008

8286

terminali ad occhio



AISI 316

A mm	D mm		
3	6,5	1	082860003
4	8,5	1	082860004
5	10,0	1	082860005
6	12,5	1	082860006
8	14,5	1	082860008

8287

terminali a tubo

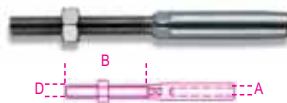

AISI 316

A mm	B mm	D mm		
3	50	M6	1	082870003
4	58	M8	1	082870004
5	66	M10	1	082870005
6	83	M12	1	082870006
8	100	M16	1	082870008

8290

ponticelli

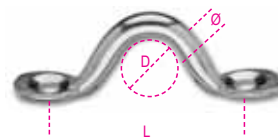

AISI 316

Ø mm	D mm	L mm		
5	12	40	1	082900005
6	16	45	1	082900006
8	13	47	1	082900008

8381SX

collari per sostegno tubazioni

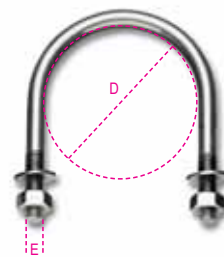

AISI 304

D mm	D gas	E mm		
11	1/8"	M6	200	083810401
14	1/4"	M6	200	083810402
18	3/8"	M6	200	083810403
22	1/2"	M6	200	083810404
27	3/4"	M6	200	083810405
34	1"	M6	200	083810406
43	1"1/4	M6	200	083810407
49	1"1/2	M8	100	083810408
61	2"	M8	100	083810409

Beta Collection

È una linea di prodotti esclusivi pensati e realizzati come espressione del carattere Beta che comprende oltre 200 creazioni originali di altissima qualità: attrezzature sportive, abbigliamento tecnico e una molteplicità di oggettistica personalizzata.

Ideali per dar vita ad iniziative promozionali, e per trascorrere momenti di svago.

Il giusto stile per vivere al meglio il vero spirito

 **Beta**



Freestyle



Freestyle sport



Classic



Racing



Work



Sales support



Junior



Golf collection



9593 SEIKO®

cronografo analogico SEIKO® al quarzo, cassa in acciaio, water resistant 10ATM, movimento giapponese



9593 SEIKO®

1 095930010



9534W

polo 3 bottoni in cotone piquè cardato 200 g bianco



S	1	095340011
M	1	095340012
L	1	095340013
XL	1	095340014
XXL	1	095340015



9553Y

camicia "racing" Yamaha® in popeline 100% cotone, 125 g



S	1	095530101
M	1	095530102
L	1	095530103
XL	1	095530104
XXL	1	095530105



9593 Breil®

orologio multifunzione digitale Breil® al quarzo, water resistant 5 ATM, quadrante LCD a 12 cifre



9593 Breil®

1 095930001



9534B

polo 3 bottoni in cotone piquè cardato 200 g blu



S	1	095340051
M	1	095340052
L	1	095340053
XL	1	095340054
XXL	1	095340055



9553K

camicia "racing" Kawasaki® in popeline 100% cotone, 125 g



S	1	095530201
M	1	095530202
L	1	095530203
XL	1	095530204
XXL	1	095530205



9593

orologio analogico da polso, cassa in acciaio e cinturino in PVC, water resistant



9593

1 095930020



9535B

t-shirt in cotone 100% 160 g



S	1	095352051
M	1	095352052
L	1	095352053
XL	1	095352054
XXL	1	095352055



9509

camicia "Indianapolis", manica corta in polycotton 65/35 con ricami diretti e applicati



L	1	095090003
XL	1	095090004



9554R

camicia F1 retrò in puro cotone



Dimensione	Quantità	Articolo
XS	1	095542000
S	1	095542001
M	1	095542002
L	1	095542003
XL	1	095542004
XXL	1	095542005

9507

felpa pesante in poliestere/cotone, 350 g



Dimensione	Quantità	Articolo
XS	1	095070000
S	1	095070001
M	1	095070002
L	1	095070003
XL	1	095070004
XXL	1	095070005

9537

pile, 100% poliestere, nero, con finitura antipilling



Dimensione	Quantità	Articolo
M	1	095370002
L	1	095370003
XL	1	095370004
XXL	1	095370005

9551G

gilet in microfibra, imbottito e foderato, blu



Dimensione	Quantità	Articolo
XS	1	095510010
S	1	095510011
M	1	095510012
L	1	095510013
XL	1	095510014
XXL	1	095510015
XXXL	1	095510016

9503

giubbino "racing" in nylon/PU



Dimensione	Quantità	Articolo
S	1	095030001
M	1	095030002
L	1	095030003
XL	1	095030004
XXL	1	095030005

9500

giaccone "Racing" originale Sparco, nero, esterno in poliammide 100%, gilet staccabile interno grigio chiaro



Dimensione	Quantità	Articolo
M	1	095001002
L	1	095001003
XL	1	095001004

9508

impermeabile tascabile in poliestere/PU



Dimensione	Quantità	Articolo
M	1	095080002
L	1	095080003
XL	1	095080004

9552

casco integrale by SUOMY®



Dimensione	Quantità	Articolo
S	1	095520101
M	1	095520102
L	1	095520103
XL	1	095520104
XXL	1	095520105

9552 JET

casco jet by SUOMY®





Dimensione	Quantità	Articolo
S	1	095520201
M	1	095520202
L	1	095520203
XL	1	095520204
XXL	1	095520205

9525/ITA

cappellino regolabile 100% cotone, logo transfer in PVC 3D sul frontale e ricami diretti. Taglia unica





9525/ITA   5 095250050

9525

cappellino, 100% cotone, taglia unica regolabile, ricamo diretto su visiera e laterale





9525   5 095251011

9525/N

cappellino, 100% cotone, taglia unica regolabile, ricamo diretto sul frontale, sui lati e sul retro, nero





9525/N   5 095251021

9525/B

cappellino, 100% cotone, taglia unica regolabile, ricamo diretto sul frontale, sui lati e sul retro, bianco



9525/B   5 095251031

9574B

guanti da lavoro



		
M	1	095740102
L	1	095740103
XL	1	095740104
XXL	1	095740105

95740

guanti da lavoro





		
M	1	095740202
L	1	095740203
XL	1	095740204
XXL	1	095740205

9564C/G

cravatta in pura seta 100%, grigia





9564C/G   1 095641001

9564C/A

cravatta in pura seta 100%, arancio



9564C/A   1 095641101

9518

cintura in "corda" 100% poliestere



cm		
90	1	095180090
100	1	095180100
110	1	095180110
120	1	095180120
130	1	095180130

9544T

trolley multifunzione con scomparto imbottito porta PC e scomparto separato portadocumenti. Misura 55x22x44



55x22x44   1 095440000

9557J

borsone sportivo in poliestere/PVC, 600D



cm
58x27x30

1 095570011

9557N

borsa "Racing" realizzata in tessuto laminato PVC, totalmente impermeabile



cm
80x35x35

1 095570001

9541

zaino sport porta PC in poliestere 600D/PVC. Inserti in 1680D e 420D/PU



cm
43x39x16

1 095410000

9543

business bag porta PC in poliestere 1680D



cm
40x28x10

1 095430000

9542

borsa a tracolla in nylon 420D



cm
35x27x10

1 095420000

9540M

marsupio multitasche in nylon 420D/PVC



9540M

1 095400011

9524PD

porta documenti da viaggio in pelle



9524PD

1 095240010

95210/OB

ombrello "racing" in nylon 190T, diametro 150 cm



95210/OB

1 095210011

9599CB

city bike Atala®, telaio in alluminio 49 cm, cambio Shimano® 6 velocità, freni V-brake®, cerchi in alluminio 28"



9599CB

1 095990011

9598MB

mountain bike Atala®, telaio in alluminio 48 cm con ammortizzatore frontale, cambio Shimano® 21 velocità, freni in alluminio V-brake®, cerchi in alluminio 26"



9598MB

1 095980011

9539C

casco bike per ciclismo, calotta esterna in policarbonato, interno in EPS nero alta densità, taglia regolabile 59-62



CE EN 1078

9539C

1 095391000



9539

completo bike, maglia in poliestere a nido d'ape, tre tasche posteriori, salopette in tessuto elasticizzato, fondello antishock antibatterico



M	1	095390013
L	1	095390014
XL	1	095390015

9528/P

pallone calcio, misura 5", in PVC



9528/P	1	095280001
--------	---	-----------

9523

set snorkeling, composto da pinne, maschera e boccaglio



Beta
by **OMERSUB**

38/39	1	095231038
40/41	1	095231040
42/43	1	095231042
44/45	1	095231044

9547WSK

"Kinder Work Station", banco da lavoro con utensili per bambini a partire da 3 anni



9547WSK	1	095473801
---------	---	-----------

9594

orologio da parete dotato di termometro ed igrometro, diametro 26 cm



Ø cm 26	1	095940051
---------------	---	-----------

9547C

calcolatrice da tavolo a 10 cifre, misura 21x29,5x1



cm 21x29,5x1	1	095470101
-----------------	---	-----------

9586

coltellino multiuso in acciaio inox, 10 funzioni



9586	1	095861001
------	---	-----------

9581

accendino, carica a benzina



9581	1	095811001
------	---	-----------

9577F1

tuta in twill di poliestere/cotone 65/35



S	1	095771001
M	1	095771002
L	1	095771003
XL	1	095771004
XXL	1	095771005
XXXL	1	095771006

9577F1/P

tuta personalizzata sul dorso



S	1	095771100
M	1	095771102
L	1	095771103
XL	1	095771104
XXL	1	095771105
XXXL	1	095771106

* Minimo 30 pz assortiti.

9579C

camice in poliestere/cotone



M	1	095791002
L	1	095791003
XL	1	095791004

9579C/P

camice personalizzato sul dorso



M	1	095791102
L	1	095791103
XL	1	095791104

* Minimo 30 pz assortiti.

9575

copertina a ventosa, in tessuto plastificato con quattro ventose sul lato superiore



9575 1 095750001

9575P

copertina a ventosa personalizzata



9575P 50 095750101

9559

striscione monofacciale in TNT, modulo da 3x0,8 m o multipli



9559 1 095591001

9590

bandiera in nylon serigrafato

cm
140x215 1 095900001**9582E**

insegna luminosa monofacciale da esterni, 30W - 220V



30x105 1 095821001

9582I/L

insegna luminosa bifacciale da interni, 30W - 220V



30x64 1 095821051

9592S/50P

50 penne a sfera in plastica



9592S/50P 1 095921001

9592P/P

penne a sfera personalizzate



9592P/P 500 095921501

9596C

portabadge in morbido cordino, con moschettone in metallo e filo portatelefono. Dotato di sgancio di sicurezza



9596C 10 095960111

9596

portabadge in poliestere con moschettone in metallo e filo portatelefono



9596 10 095961001

9595S/10P

10 portachiavi in materiale plastico tipo EVA



9595S/10P 1 095951001

9569

shopper in resistente polietilene, con soffiati laterali



cm 44x34 50 095691001

9588S/10...

set di 10 block notes



9588S/10A 21x29 cm 1 095881001

9588S/10B 15x21 cm 1 095881002

9588S/10C 10x15 cm 1 095881003

9588S/10D 7,5x10,5 cm 1 095880054

9588/10PI

set di 10 blocchetti per appunti con fogli adesivi



9588/10PI 7,5x7,5 cm 1 095880055

9591S/...

adesivi trasparenti



* 9591 S/10A 60x14,6 cm 1 095911001

* 9591 S/10B 38x10,7 cm 1 095911002

* 9591 S/50C 26x7,8 cm 1 095911003

* 9591 S/50D 13x3,9 cm 1 095911004

* I prezzi indicati sono relativi a 10 pezzi
° I prezzi indicati sono relativi a 50 pezzi

9589A/36

confezione da 36 rotoli di nastro adesivo per imballo, logo Beta, avana



9589A/36 1 095890035

9589B/36

confezione da 36 rotoli di nastro adesivo per imballo, logo Beta, bianco



9589B/36 1 095890036



9511

giacca antipioggia,
100% poliammide Singtex® 5000



L	1	095110003
XL	1	095110004
XXL	1	095110005

9516

pull antivento, in tessuto a tre strati
con membrana traspirante, impermeabile



L	1	095160003
XL	1	095160004
XXL	1	095160005

9512

pull in pile, 100% poliestere,
trattato Quick Dry e Teflon®



L	1	095120003
XL	1	095120004
XXL	1	095120005

9514

pullover in 100% cachemire, finezza 12,
peso 280/300 g



L	1	095140003
XL	1	095140004

9517

gilet in lana, foderato con membrana
Singtex® 5000 antivento ed antiacqua



S	1	095170001
M	1	095170002
L	1	095170003
XL	1	095170004
XXL	1	095170005

9515

gilet in 100% cachemire, finezza 12,
peso 220/240g



M	1	095150002
L	1	095150003
XL	1	095150004

9513

gilet in pile, trattato Quick Dry e Teflon®



L	1	095130003
XL	1	095130004
XXL	1	095130005

9549CART

sacca da golf 9,5" con 14 divisori,
tasche con zip dry e tasca frigo



9549CART	1	095490101
----------	---	-----------

9549CS

coprisacca da pioggia in nylon 420D/PVC



9549CS	1	095491020
--------	---	-----------

Articoli ad esaurimento

98ES

D mm	
7 (6R)	000980307
9 (8R)	000980309

388B

388B	003880101
------	-----------

388B/1

388B/1	003880110
--------	-----------

388B/M

388B/M10	003880120
388B/M12	003880122
388B/M14	003880124
388B/M16	003880126
388B/M18	003880128
388B/M20	003880130
388B/M22	003880132

388B/C9

388B/C9	003880150
---------	-----------

720IA

mm	
17	007200487
19	007200489
21	007200491

720IA/S3

mm	
17-19-21	007200493

900MB/SB

900MB/SB11	009000180
------------	-----------

928AS/C8

928AS/C8	009280950
----------	-----------

928.../C9

928A/C9	009280952
928B/C9	009280956

1083S

L ~	
180	010830018
200	010830020

1166TM

L ~	
160	011660046
200	011660050

1167S

L ~	
160	011670016
200	011670020

1168TM

L ~	
160	011680046
200	011680050

1169S

L ~	
160	011690016
200	011690020

1301

g	
835	013010001

1369/C11

1369/C11	013690022
----------	-----------

1441

1441	014410010
------	-----------

1459

1459	014590001
------	-----------

1466

1466	014660001
------	-----------

1468/1 - 2 - 3

1468/1	014680001
1468/2	014680002
1468/3	014680003

1479/S5

1479/S5	014790200
---------	-----------

1485B

1485B	014850020
-------	-----------

1500N/SP

1500N/SP5	015000026
-----------	-----------

1568/K13

mm	
3-4-5	015680051

1602/C9

1602/C9	016020012
---------	-----------

1604/C9

1604/C9	016040012
---------	-----------

1608/C9

1608/C9	016080012
---------	-----------

1713

L mm	
500	017130001
1000	017130005

1737MP

1737MP	017370030
--------	-----------

1759HD

1759HD	017590051
--------	-----------

1830A

1830A	018300010
-------	-----------

1835A

1835A	018350010
-------	-----------

1927

1927	019270001
------	-----------

1927R

1927R	019270011
-------	-----------

1930PG

1930PG	019300002
--------	-----------

1930PGR

1930PGR	019300012
---------	-----------

1949D

1949D	019490015
-------	-----------

1949E

1949E	019490017
-------	-----------

2010E

2010E/1A	020100170
2010E/2A	020100180

2010N/BV

2010N/BV	020100200
----------	-----------

2014/U

2014/U	020140100
--------	-----------

2014/VV

2014/VV	020140101
---------	-----------

2015I/1

2015I/1	020150030
---------	-----------

2015N/BV

2015N/BV	020150200
----------	-----------

2050L

2050L	020500012
-------	-----------

2060/A

2060/A	020600010
--------	-----------

CD23

CD23 O	023000110
CD23 G	023000111
CD23 R	023000112

C26 - 2600

C26 O	026000011
-------	-----------

C50

C50	050000011
-----	-----------

ASSORTIMENTI DI UTENSILI

2600/VCR1	026000047
2600/VG0	026000061
2600/VG4	026000068
2600/VI1	026000341
5908/VI/2	059080041
5910/VI/1	059100031



T...

T130	024240130
T133	024240133
T262	024240262
T272	024240272





Articoli ad esaurimento



7254N

		
EU	UK	
38	5	072540038
39	6	072540039
40	6,5	072540040
41	7	072540041
42	8	072540042
43	9	072540043
44	10	072540044
45	10,5	072540045
46	11	072540046
47	12	072540047



7255N

		
EU	UK	
38	5	072550038
39	6	072550039
40	6,5	072550040
41	7	072550041
42	8	072550042
43	9	072550043
44	10	072550044
45	10,5	072550045
46	11	072550046
47	12	072550047



7256N

		
EU	UK	
38	5	072560038
39	6	072560039
40	6,5	072560040
41	7	072560041
42	8	072560042
43	9	072560043
44	10	072560044
45	10,5	072560045
46	11	072560046
47	12	072560047



7257N

		
EU	UK	
38	5	072570038
39	6	072570039
40	6,5	072570040
41	7	072570041
42	8	072570042
43	9	072570043
44	10	072570044
45	10,5	072570045
46	11	072570046
47	12	072570047



7290NKK

		
EU	UK	
38	5	072900138
39	6	072900139
40	6,5	072900140
41	7	072900141
42	8	072900142
43	9	072900143
44	10	072900144
45	10,5	072900145
46	11	072900146
47	12	072900147



7291NKK

		
EU	UK	
38	5	072910138
39	6	072910139
40	6,5	072910140
41	7	072910141
42	8	072910142
43	9	072910143
44	10	072910144
45	10,5	072910145
46	11	072910146
47	12	072910147



7306

		
EU	UK	
36	3,5	073060036
37	4,5	073060037
38	5	073060038
39	6	073060039
40	6,5	073060040
41	7	073060041
42	8	073060042
43	9	073060043
44	10	073060044
45	10,5	073060045
46	11	073060046
47	12	073060047
48	13	073060048



7331NKK

		
EU	UK	
35	2,5	073310035
36	3,5	073310036
37	4,5	073310037
38	5	073310038
39	6	073310039
40	6,5	073310040
41	7	073310041
42	8	073310042
43	9	073310043
44	10	073310044
45	10,5	073310045
46	11	073310046
47	12	073310047



7337NKK

		
EU	UK	
38	5	073370038
39	6	073370039
40	6,5	073370040
41	7	073370041
42	8	073370042
43	9	073370043
44	10	073370044
45	10,5	073370045
46	11	073370046
47	12	073370047

7338NKK

		
EU	UK	
38	5	073380038
39	6	073380039
40	6,5	073380040
41	7	073380041
42	8	073380042
43	9	073380043
44	10	073380044
45	10,5	073380045
46	11	073380046
47	12	073380047

7386A

		
EU	UK	
36	3,5	073860136
37	4,5	073860137
38	5	073860138
39	6	073860139
40	6,5	073860140
41	7	073860141
42	8	073860142
43	9	073860143
44	10	073860144
45	10,5	073860145



7501

		
S		075010048
M		075010050
L		075010052
XL		075010054
XXL		075010056



7535

		
S		075350001
M		075350002
L		075350003
XL		075350004
XXL		075350005

7721

		
XS		077210000
S		077210001
M		077210002
L		077210003
XL		077210004
XXL		077210005
XX		077210006

7790

		
S		077900101
M		077900102
L		077900103
XL		077900104
XXL		077900105

Robur

8005F

AxL	
mm	
* M16x300	080050901
° M16x500	080050903
* M20x380	080050906
° M20x580	080050908

8018F

Ø	
mm	
6-8	080180058
8-10	080180060
10-14	080180064
14-18	080180068

8105

ØxL	
"	
7/8x12	081050022

8109

ØxL	
"	
1/2x9	081090012
1"1/4x12	081090031

Beta

Condizioni generali di vendita

Gli ordini trasmessi per l'acquisto di prodotti dalla Beta Utensili SpA (d'ora in poi "Beta" o "Società") comportano l'accettazione automatica e senza riserve delle presenti Condizioni Generali di Vendita che costituiscono parte integrante del contratto di vendita. Eventuali deroghe alle stesse saranno efficaci solo se concordate per iscritto dalle parti e limitatamente alle vendite cui si riferiscono.

PRODOTTI

I pesi, le dimensioni, i prezzi, i colori e gli altri dati figuranti nei cataloghi, prospetti, circolari, od altri documenti illustrativi della Società, hanno carattere di indicazioni approssimative.

Beta si riserva di variare in qualsiasi momento, senza preavviso, i dati tecnici o costruttivi dei suoi prodotti.

ORDINI

Le presenti Condizioni Generali di Vendita si intendono approvate dall'acquirente con la trasmissione dell'ordine, ordine che viene ricevuto dalla Società sempre con la clausola "salvo approvazione della casa". Beta può accettare l'ordine mediante spedizione della merce, conformemente all'art. 1327 c.c..

Nell'ordine deve essere specificato il codice dell'articolo e la relativa quantità.

Le quantità minime sono indicate nel listino per ciascun articolo. Ordini non corrispondenti ad esse, od ai loro multipli, verranno automaticamente adeguati senza previa autorizzazione al Cliente.

RIMANENZE

La Società si riserva la facoltà di evadere l'ordine tutto o in parte ovvero in diverse riprese. Nell'eventualità di ordini non completamente evasi Beta invierà tramite e-mail una distinta riepilogativa delle rimanenze di detti ordini che, salvo espressa richiesta contraria, saranno incluse nella o nelle spedizioni successive. Previa specifica richiesta del Cliente tali informazioni verranno trasmesse via fax.

TERMINI DI CONSEGNA

Eventuali termini di consegna, comunque e dovunque previsti, avranno valore puramente indicativo. La Società declina ogni responsabilità per il caso di ritardo nella consegna che non derivi da suo dolo o colpa grave. Il mancato rispetto dei termini di consegna, purché contenuto in un ragionevole lasso di tempo, non dà diritto al Cliente di richiedere un risarcimento, né di annullare gli Ordini, a meno che, avuto riguardo alla normale tollerabilità ed alla natura del contratto ed alla fornitura, la stessa non abbia più importanza per il Cliente. In questo caso l'onere probatorio sarà a carico del Cliente stesso.

Salvo il caso di dolo o colpa grave della Società, è espressamente escluso qualsiasi risarcimento del danno per mancata o ritardata consegna dei prodotti.

GESTIONE ORDINI, SPEDIZIONI E IMBALLI

Le spedizioni sono effettuate franco destino, con mezzi di trasporto a scelta della Società per gli ordini netti superiori ad € 800,00.

Per gli ordini inferiori ad € 800,00 verrà addebitato a titolo di contributo spese di trasporto il seguente importo:

contributo fisso di € 10,00 fino ad € 199,99

contributo pari al 3,50% da € 200,00 ad € 799,99.

L'imballo è gratuito quando non richiesto di tipo particolare.

Il trasferimento dei rischi relativi ai prodotti ha luogo al momento della loro consegna al Vettore: conseguentemente, i prodotti viaggiano a rischio e pericolo del destinatario anche in caso di spedizione porto franco.

L'Acquirente che sia già cliente abituale potrà rivolgersi direttamente al **Deposito Beta di Milano** anche per quantità diverse dall'unità di confezionamento previste. Il costo del servizio verrà addebitato nella misura forfetaria del 6% in sede di fatturazione e le spese di spedizione saranno a carico del Cliente.

PREZZI

L'indicazione di prezzo contenuta in cataloghi, listini, ecc. è meramente indicativa e potrà quindi subire variazioni senza necessità di preventiva informazione. Salvo diverso accordo tra le parti, la merce sarà fatturata ai prezzi in vigore al momento della spedizione.

I prezzi si intendono al netto di iva, di eventuali imposte o tasse, nonché di tributi, diritti ed oneri fiscali o di qualsiasi specie eventualmente gravanti sul contratto che restano a carico esclusivo del Cliente.

PAGAMENTI

Il pagamento deve essere corrisposto direttamente presso la sede della Società in Via Volta n. 18 - 20050 SOVICO (MB) ovvero alla persona munita di autorizzazione scritta con le modalità e nei termini indicati nella fattura.

Sconti per pagamenti a breve termine vanno calcolati sull'importo netto della merce, escluso imballo, spese postali o di trasporto e iva. Trascorsi 15 giorni dalla data della fattura o dal periodo concordato, si intende revocato il beneficio dello sconto condizionato e pertanto la rimessa andrà effettuata per il totale della fattura.

Il ritardato pagamento rispetto alla data pattuita darà luogo all'addebito degli interessi di mora di cui all'art. 5 del D.Lgs. 231/02 e produrrà la perdita per il Cliente del beneficio del termine ai sensi dell'art. 1186 cod. civ., rendendo immediatamente esigibili eventuali somme non ancora scadute.

Il Cliente non è autorizzato ad effettuare alcuna deduzione dal prezzo pattuito (ad es. in caso di pretesi difetti dei prodotti), se non previo accordo scritto con la Società.

GARANZIA

I prodotti venduti da Beta sono garantiti in relazione a vizi o difetti di fabbricazione; la garanzia è limitata alla sostituzione o riparazione dei prodotti riconosciuti difettosi presso la sede della Società, con esclusione di qualsiasi diritto al risarcimento dei danni. La suddetta garanzia non si applica a prodotti che presentano normale usura, segni di manomissione o di uso improprio. Le spese di trasporto dei prodotti da sostituire o riparare e dei prodotti sostituiti o riparati sono a carico dell'Acquirente.

In presenza dei presupposti di cui al comma precedente Beta sostituirà o riparerà gratuitamente il Prodotto riscontrato difettoso all'origine se reso franco sede della Società con relativo documento di trasporto sul quale dovranno essere indicati, oltre alla dicitura merce difettosa, gli estremi della fattura emessa all'atto della vendita.

Salvo il caso di dolo o colpa grave, la Società sarà tenuta, in caso di vizi o mancanza di qualità dei prodotti, unicamente alla riparazione o sostituzione dei prodotti difettosi. È inteso che la suddetta garanzia (consistente nell'obbligo di riparare o sostituire i prodotti) comprende e sostituisce ogni garanzia o responsabilità della Società (sia contrattuale che extracontrattuale) comunque originata dai prodotti forniti (ad es. risarcimento del danno, mancato guadagno ecc.).

RECLAMI

Il Cliente deve denunciare gli eventuali vizi e difetti dei prodotti forniti o l'eventuale mancata o difforme fornitura di tutto o parte dell'Ordine d'Acquisto, a pena di decadenza, entro il termine di 8 (otto) giorni da calcolarsi rispettivamente dalla data di consegna dei prodotti (vizi apparenti) e/o da quella della scoperta dei vizi o difetti (vizi occulti). Nel caso di vizi palesi la denuncia dovrà essere fatta per iscritto a mezzo di lettera raccomandata a.r..

Eventuali contestazioni non danno diritto al Cliente di sospendere o comunque ritardare i pagamenti dei prodotti oggetto di contestazione né, tanto meno, di altre forniture.

La garanzia non opera nel caso in cui l'Acquirente abbia eseguito o fatto eseguire interventi da parte di terzi sui prodotti, senza il preventivo consenso scritto di Beta. La merce difettosa, qualora non presenti inconvenienti dovuti a normale logorio, errato uso o evidente manomissione, verrà riparata o sostituita gratuitamente solo se restituita in porto franco presso la sede della Società, indicando nel documento di accompagnamento la causale e gli estremi della fattura relativa.

RESI

Eventuali resi di merce vengono accettati solo se preventivamente concordati e autorizzati per iscritto; contrariamente saranno rispediti al mittente con trasporto a proprio carico.

In ogni caso nel documento di accompagnamento devono essere indicati la causale del reso ed il numero di autorizzazione ricevuto.

Tali resi dovranno essere inviati presso la sede della Società in **Via Volta n. 18 - 20050 SOVICO (MB)**.

FORO COMPETENTE

Le presenti Condizioni Generali di Vendita sono regolate dalle leggi della Repubblica Italiana. Per tutto quanto non espressamente regolato dalle presenti condizioni, sarà applicata la normativa del codice civile.

Per qualsiasi controversia derivante dal contratto di vendita disciplinati dalle presenti Condizioni Generali di Vendita o ad esso collegata sarà esclusivamente competente il Foro di Monza, fatte comunque salve diverse inderogabili norme di legge.

Condizioni generali di vendita

Gli ordini trasmessi per l'acquisto di prodotti Robur dalla Beta Utensili SpA (d'ora in poi "Beta" o "Società") devono essere inviati alla nostra sede produttiva di Sulmona e comportano l'accettazione automatica e senza riserve delle presenti Condizioni Generali di Vendita che costituiscono parte integrante del contratto di vendita. Eventuali deroghe alle stesse saranno efficaci solo se concordate per iscritto dalle parti e limitatamente alle vendite cui si riferiscono.

PRODOTTI

I pesi, le dimensioni, i prezzi, i colori e gli altri dati figuranti nei cataloghi, prospetti, circolari, od altri documenti illustrativi della Società, hanno carattere di indicazioni approssimative.

Beta si riserva di variare in qualsiasi momento, senza preavviso, i dati tecnici o costruttivi dei suoi prodotti.

ORDINI

Le presenti Condizioni Generali di Vendita si intendono approvate dall'acquirente con la trasmissione dell'ordine, ordine che viene ricevuto dalla Società sempre con la clausola "salvo approvazione della casa". Beta può accettare l'ordine mediante spedizione della merce, conformemente all'art. 1327 c.c..

Nell'ordine deve essere specificato il codice dell'articolo e la relative quantità.

Le quantità minime sono indicate nel listino per ciascun articolo. Ordini non corrispondenti ad esse, od ai loro multipli, verranno automaticamente adeguati senza previa autorizzazione al Cliente.

RIMANENZE

La Società si riserva la facoltà di evadere l'ordine tutto o in parte ovvero in diverse riprese. Nell'eventualità di ordini non completamente evasi Beta invierà tramite e-mail una distinta riepilogativa delle rimanenze di detti ordini che, salvo espressa richiesta contraria, saranno incluse nella o nelle spedizioni successive. Previa specifica richiesta del Cliente tali informazioni verranno trasmesse via fax.

TERMINI DI CONSEGNA

Eventuali termini di consegna, comunque e dovunque previsti, avranno valore puramente indicativo. La Società declina ogni responsabilità per il caso di ritardo nella consegna che non derivi da suo dolo o colpa grave. Il mancato rispetto dei termini di consegna, purché contenuto in un ragionevole lasso di tempo, non dà diritto al Cliente di richiedere un risarcimento, né di annullare gli Ordini, a meno che, avuto riguardo alla normale tollerabilità ed alla natura del contratto ed alla fornitura, la stessa non abbia più importanza per il Cliente. In questo caso l'onere probatorio sarà a carico del Cliente stesso.

Salvo il caso di dolo o colpa grave della Società, è espressamente escluso qualsiasi risarcimento del danno per mancata o ritardata consegna dei prodotti.

GESTIONE ORDINI, SPEDIZIONI E IMBALLI

Le spedizioni sono effettuate franco destino con addebito delle spese in fattura con mezzi di trasporto a scelta della Società.

L'imballo è gratuito quando non richiesto di tipo particolare.

Il trasferimento dei rischi relativi ai prodotti ha luogo al momento della loro consegna al Vettore: conseguentemente, i prodotti viaggiano a rischio e pericolo del destinatario anche in caso di spedizione porto franco.

L'Acquirente che sia già cliente abituale potrà rivolgersi direttamente al **Deposito Beta di Milano** anche per quantità diverse dall'unità di confezionamento previste. Il costo del servizio verrà addebitato nella misura forfetaria del 6% in sede di fatturazione e le spese di spedizione saranno a carico del Cliente.

PREZZI

L'indicazione di prezzo contenuta in cataloghi, listini, ecc. è meramente indicativa e potrà quindi subire variazioni senza necessità di preventiva informazione. Salvo diverso accordo tra le parti, la merce sarà fatturata ai prezzi in vigore al momento della spedizione.

I prezzi si intendono al netto di iva, di eventuali imposte o tasse, nonché di tributi, diritti ed oneri fiscali o di qualsiasi specie eventualmente gravanti sul contratto che restano a carico esclusivo del Cliente.

PAGAMENTI

Il pagamento deve essere corrisposto direttamente presso la sede della Società in Via Volta n. 18, 20050 Sovico (MB) ovvero alla persona munita di autorizzazione

scritta con le modalità e nei termini indicati nella fattura.

Sconti per pagamenti a breve termine vanno calcolati sull'importo netto della merce, escluso imballo, spese postali o di trasporto e iva. Trascorsi 15 giorni dalla data della fattura o dal periodo concordato, si intende revocato il beneficio dello sconto condizionato e pertanto la rimessa andrà effettuata per il totale della fattura. Il ritardato pagamento rispetto alla data pattuita darà luogo all'addebito degli interessi di mora di cui all'art. 5 del D.Lgs. 231/02 e produrrà la perdita per il Cliente del beneficio del termine ai sensi dell'art. 1186 cod. civ., rendendo immediatamente esigibili eventuali somme non ancora scadute.

Il Cliente non è autorizzato ad effettuare alcuna deduzione dal prezzo pattuito (ad es. in caso di pretesi difetti dei prodotti), se non previo accordo scritto con la Società.

GARANZIA

I prodotti venduti da Beta sono garantiti in relazione a vizi o difetti di fabbricazione; la garanzia è limitata alla sostituzione o riparazione dei prodotti riconosciuti difettosi presso la sede della Società, con esclusione di qualsiasi diritto al risarcimento dei danni. La suddetta garanzia non si applica a prodotti che presentano normale usura, segni di manomissione o di uso improprio. Le spese di trasporto dei prodotti da sostituire o riparare e dei prodotti sostituiti o riparati sono a carico dell'Acquirente.

In presenza dei presupposti di cui al comma precedente Beta sostituirà o riparerà gratuitamente il Prodotto riscontrato difettoso all'origine se reso franco sede della Società con relativo documento di trasporto sul quale dovranno essere indicati, oltre alla dicitura merce difettosa, gli estremi della fattura emessa all'atto della vendita.

Salvo il caso di dolo o colpa grave, la Società sarà tenuta, in caso di vizi o mancanza di qualità dei prodotti, unicamente alla riparazione o sostituzione dei prodotti difettosi. È inteso che la suddetta garanzia (consistente nell'obbligo di riparare o sostituire i prodotti) comprende e sostituisce ogni garanzia o responsabilità della Società (sia contrattuale che extracontrattuale) comunque originata dai prodotti forniti (ad es. risarcimento del danno, mancato guadagno ecc.).

RECLAMI

Il Cliente deve denunciare gli eventuali vizi e difetti dei prodotti forniti o l'eventuale mancata o difforme fornitura di tutto o parte dell'Ordine d'Acquisto, a pena di decadenza, entro il termine di 8 (otto) giorni da calcolarsi rispettivamente dalla data di consegna dei prodotti (vizi apparenti) e/o da quella della scoperta dei vizi o difetti (vizi occulti). Nel caso di vizi palesi la denuncia dovrà essere fatta per iscritto a mezzo di lettera raccomandata a.r..

Eventuali contestazioni non danno diritto al Cliente di sospendere o comunque ritardare i pagamenti dei prodotti oggetto di contestazione né, tanto meno, di altre forniture.

La garanzia non opera nel caso in cui l'Acquirente abbia eseguito o fatto eseguire interventi da parte di terzi sui prodotti, senza il preventivo consenso scritto di Beta. La merce difettosa, qualora non presenti inconvenienti dovuti a normale logorio, errato uso o evidente manomissione, verrà riparata o sostituita gratuitamente solo se restituita in porto franco presso la sede della Società, indicando nel documento di accompagnamento la causale e gli estremi della fattura relativa.

RESI

Eventuali resi di merce vengono accettati solo se preventivamente concordati e autorizzati per iscritto; contrariamente saranno rispediti al mittente con trasporto a proprio carico.

In ogni caso nel documento di accompagnamento devono essere indicati la causale del reso ed il numero di autorizzazione ricevuto.

Tali resi dovranno essere inviati presso la sede produttiva della Società in **Zona Industriale - Contrada S. Nicola - 67039 SULMONA (AQ)**.

FORO COMPETENTE

Le presenti Condizioni Generali di Vendita sono regolate dalle leggi della Repubblica Italiana. Per tutto quanto non espressamente regolato dalle presenti condizioni, sarà applicata la normativa del codice civile.

Per qualsiasi controversia derivante dal contratto di vendita disciplinati dalle presenti Condizioni Generali di Vendita o ad esso collegata sarà esclusivamente competente il Foro di Monza, fatte comunque salve diverse inderogabili norme di legge.



LUCIANO FORMIA
VALLE D'AOSTA
PIEMONTE: Torino, Asti, Cuneo, Alessandria
 Cell. 335.1261210
 Fax 011.9606568
 lucianofornia@tiscali.it

ALESSANDRO DE SANCTIS
LIGURIA
 Cell. 348.3008699
 Fax 019.90085
 alessanc@libero.it

ROBERTO RADAELLI
LOMBARDIA NORD OVEST: Como, Sondrio, Varese, provincia Nord Milano, Monza
PIEMONTE: Novara, Vercelli, Biella, Verbania
 Tel. 039.2010558
 Cell. 337.756200
 Fax 039.2015252
 roal2003@tiscali.it

LUIGI FUMAGALLI SAS
LOMBARDIA SUD OVEST: Lodi, Pavia, Milano città, provincia Sud Milano
 Tel. 02.4078792
 Cell. 335.214487
 Fax 039.570186
 lfrappresentanze@tiscalinet.it

AVIDANO SIMEONI
LOMBARDIA NORD EST: Provincia Est Milano (esclusi i comuni della provincia di Monza), Bergamo, Lecco
 Cell. 335.5296941
 Fax 02.3506882
 avidanosimeoni@alice.it

MARCO VESENTINI
LOMBARDIA SUD EST: Brescia, Mantova, Cremona
VENETO: Verona
 Cell. 346.0831683
 Fax 0376.809741
 marcovesentini@tiscali.it

TARGA SERGIO & C. SAS
TRENTINO ALTO ADIGE
VENETO: Vicenza
 Cell. 348.4112065
 Fax 0461.530550
 targa_s70@yahoo.it

DAVIDE CARRARO
VENETO: Padova, Rovigo, Venezia Ovest
 Cell. 335.5338608
 Fax 049.8657039
 davide.carraro@tin.it

NICOLA MION
VENETO: Belluno, Treviso, Venezia Est
 Cell. 335.8427204
 Fax 0422.452468
 n.mion@virgilio.it

MAURO BARBOTTI & C. SAS
FRIULI VENEZIA GIULIA
 Cell. 338.4070716
 Fax 040.830630
 maurobarbotticisas@gmail.com

RAMS DI MIRKO SPOTO
EMILIA ROMAGNA: Modena, Parma, Reggio Emilia, Piacenza
 Cell. 335.6767165
 Fax 051.6646204
 info@ramsmirkospoto.it
 mirkospoto@libero.it

RIEM - MARCO MALAGUTI
EMILIA ROMAGNA: Bologna, Ferrara, Ravenna, Forlì-Cesena, Rimini
 Tel. 059.468050
 Cell. 335.5488324
 Fax 059.468028
 info@ariem-riem.com

STEFANO CAMERINI
TOSCANA: Firenze, Pistoia, Prato, Livorno, Pisa, Lucca, Massa Carrara
 Cell. 347.5084765
 Fax 055.289350
 camerini.stefano@tiscali.it

GABBI PAOLO E GABBI SIMONE SNC
TOSCANA: Grosseto, Siena, Arezzo
UMBRIA
 Cell. 348.7105920 (Paolo)
 Cell. 335.6549612 (Simone)
 Fax 0575.351998
 gabbis@libero.it
 gabbip@tiscalinet.it

ALEX CAPPANERA
MARCHE
 Tel. 071.914734
 Cell. 339.4718269
 Fax 0731.209169
 alex@cappanera.it

MAURO BISOGNINI
ABRUZZO - MOLISE
 Tel. 071.2862055
 Fax 071.2863155
 info@maurobisognini.it

DANIELE MARINELLI
LAZIO
 Tel. 06.8177774 - 06.8183359
 Cell. 335.5394617
 Fax 06.8181378
 marinellidan@tiscali.it

ANTONINO SCOGNAMIGLIO
CAMPANIA: Benevento, Caserta, Napoli Nord
 Cell. 335.5281534
 Fax 081.2140299
 antonino.scognamiglio@fastwebnet.it

ESPOSITO RAPPRESENTANZE
CAMPANIA: Avellino, Salerno, Napoli Sud
BASILICATA: Potenza
 Cell. 335.6212740
 Fax 081.2140299
 alfredo-esposito@fastwebnet.it

GIOVANNI PEPE
PUGLIA
BASILICATA: Matera
 Cell. 393.3334452
 Fax 080.5492313
 giovanni pepe_001@fastwebnet.it

DOMENICO ARAGONA
CALABRIA
 Cell. 337.872220
 Fax 0984.849638
 domenicoaragona@virgilio.it

SALVATORE TUDISCO
SICILIA EST: Messina, Catania
 Cell. 335.8064374
 Fax 095.7270564
 info@agenziatudisco.it

RITA ITALIA
SICILIA EST: Siracusa, Ragusa, Enna
 Cell. 338.6365091
 Fax 0931.870400
 ritaitalia@gmail.com

GIUSEPPE CASSARÀ
SICILIA OVEST: Palermo, Trapani, Caltanissetta, Agrigento
 Cell. 329.4207410
 Fax 091.9770384
 cassara.giuseppe54@tiscali.it

PI.CO - LUCIANO COMPARETTI
SARDEGNA: Oristano, Cagliari
 Cell. 349.4977448
 Fax 070.41674
 pico.comparetti@tiscali.it

PI.CO - SALVATORE PILLA
SARDEGNA: Sassari, Nuoro
 Cell. 349.4977449
 Fax 079.501493
 pico.pilla@tiscali.it



LUCIANO FORMIA
VALLE D'AOSTA
PIEMONTE: Torino, Asti, Cuneo, Alessandria
 Cell. 335.1261210
 Fax 011.9606568
 lucianoformia@tiscali.it

ALESSANDRO DE SANCTIS
LIGURIA
 Cell. 348.3008699
 Fax 019.90085
 alessanc@libero.it

ROBERTO RADAELLI
LOMBARDIA NORD OVEST: Como, Sondrio, Varese, provincia Nord Milano, Monza
PIEMONTE: Novara, Vercelli, Biella, Verbania
 Tel. 039.2010558
 Cell. 337.756200
 Fax 039.2015252
 roal2003@tiscali.it

LUIGI FUMAGALLI SAS
LOMBARDIA SUD OVEST: Lodi, Pavia, Milano città, provincia Sud Milano
 Tel. 02.4078792
 Cell. 335.214487
 Fax 039.570186
 lfrappresentanze@tiscalinet.it

AVIDANO SIMEONI
LOMBARDIA NORD EST: Provincia Est Milano (esclusi i comuni della provincia di Monza), Bergamo, Lecco
 Cell. 335.5296941
 Fax 02.3506882
 avidanosimeoni@alice.it

MARCO VESENTINI
LOMBARDIA SUD EST: Brescia, Mantova, Cremona
VENETO: Verona
 Cell. 346.0831683
 Fax 0376.809741
 marcovesentini@tiscali.it

TARGA SERGIO & C. SAS
TRENTINO ALTO ADIGE
VENETO: Vicenza
 Cell. 348.4112065
 Fax 0461.530550
 targa_s70@yahoo.it

DAVIDE CARRARO
VENETO: Padova, Rovigo, Venezia Ovest
 Cell. 335.5338608
 Fax 049.8657039
 davide.carraro@tin.it

NICOLA MION
VENETO: Belluno, Treviso, Venezia Est
 Cell. 335.8427204
 Fax 0422.452468
 n.mion@virgilio.it

MAURO BARBOTTI & C. SAS
FRIULI VENEZIA GIULIA
 Cell. 338.4070716
 Fax 040.830630
 maurobarbotticzas@gmail.com

RAMS DI MIRKO SPOTO
EMILIA ROMAGNA: Modena, Parma, Reggio Emilia, Piacenza
 Cell. 335.6767165
 Fax 051.6646204
 info@ramsmirkospoto.it
 mirkospoto@libero.it

RIEM - MARCO MALAGUTI
EMILIA ROMAGNA: Bologna, Ferrara, Ravenna, Forlì-Cesena, Rimini
 Tel. 059.468050
 Cell. 335.5488324
 Fax 059.468028
 info@ariem-riem.com

STEFANO CAMERINI
TOSCANA: Firenze, Pistoia, Prato, Livorno, Pisa, Lucca, Massa Carrara
 Cell. 347.5084765
 Fax 055.289350
 camerini.stefano@tiscali.it

GABBI PAOLO E GABBI SIMONE SNC
TOSCANA: Grosseto, Siena, Arezzo
UMBRIA
 Cell. 348.7105920 (Paolo)
 Cell. 335.6549612 (Simone)
 Fax 0575.351998
 gabbis@libero.it
 gabbip@tiscalinet.it

ALEX CAPPANERA
MARCHE
 Tel. 071.914734
 Cell. 339.4718269
 Fax 0731.209169
 alex@cappanera.it

FRANCESCO BIBONE
ABRUZZO - MOLISE
 Cell. 338.4576367
 Fax 085.2058663
 fbibone@yahoo.it

DANIELE MARINELLI
LAZIO
 Tel. 06.8177774 - 06.8183359
 Cell. 335.5394617
 Fax 06.8181378
 marinellidan@tiscali.it

ANTONINO SCOGNAMIGLIO
CAMPANIA: Benevento, Caserta, Napoli Nord
 Cell. 335.5281534
 Fax 081.2140299
 antonino.scognamiglio@fastwebnet.it

ESPOSITO RAPPRESENTANZE
CAMPANIA: Avellino, Salerno, Napoli Sud
BASILICATA: Potenza
 Cell. 335.6212740
 Fax 081.2140299
 alfredo-esposito@fastwebnet.it

CESARE GIANNINI
PUGLIA
BASILICATA: Matera
 Cell. 338.7302333
 Fax 080.4553101
 gianninicesare@libero.it

DOMENICO ARAGONA
CALABRIA
 Cell. 337.872220
 Fax 0984.849638
 domenicoaragona@virgilio.it

SALVATORE TUDISCO
SICILIA EST: Messina, Catania
 Cell. 335.8064374
 Fax 095.7270564
 info@agenziatudisco.it

RITA ITALIA
SICILIA EST: Siracusa, Ragusa, Enna
 Cell. 338.6365091
 Fax 0931.870400
 ritaitalia@gmail.com

GIUSEPPE CASSARÀ
SICILIA OVEST: Palermo, Trapani, Caltanissetta, Agrigento
 Cell. 329.4207410
 Fax 091.9770384
 cassara.giuseppe54@tiscali.it

PI.CO - LUCIANO COMPARETTI
SARDEGNA: Oristano, Cagliari
 Cell. 349.4977448
 Fax 070.41674
 pico.comparetti@tiscali.it

PI.CO - SALVATORE PILLA
SARDEGNA: Sassari, Nuoro
 Cell. 349.4977449
 Fax 079.501493
 pico.pilla@tiscali.it



LUCIANO FORMIA
VALLE D'AOSTA
PIEMONTE: Torino, Asti, Cuneo, Alessandria
 Cell. 335.1261210
 Fax 011.9606568
 lucianofornia@tiscali.it

ALEX CAPPANERA
MARCHE
 Tel. 071.914734
 Cell. 339.4718269
 Fax 0731.209169
 alex@cappanera.it

ALESSANDRO DE SANCTIS
LIGURIA
 Cell. 348.3008699
 Fax 019.90085
 alessanc@libero.it

MAURO BISOGNINI
ABRUZZO - MOLISE
 Tel. 071.2862055
 Fax 071.2863155
 info@maurobisognini.it

ROBERTO RADAELLI
LOMBARDIA NORD OVEST: Como, Sondrio, Varese, provincia Nord Milano, Monza
PIEMONTE: Novara, Vercelli, Biella, Verbania
 Tel. 039.2010558
 Cell. 337.756200
 Fax 039.2015252
 roal2003@tiscali.it

DANIELE MARINELLI
LAZIO
 Tel. 06.8177774 - 06.8183359
 Cell. 335.5394617
 Fax 06.8181378
 marinellidan@tiscali.it

LUIGI FUMAGALLI SAS
LOMBARDIA SUD OVEST: Lodi, Pavia, Milano città, provincia Sud Milano
 Tel. 02.4078792
 Cell. 335.214487
 Fax 039.570186
 lfrappresentanze@tiscalinet.it

ANTONINO SCOGNAMIGLIO
CAMPANIA: Benevento, Caserta, Napoli Nord
 Cell. 335.5281534
 Fax 081.2140299
 antonino.scognamiglio@fastwebnet.it

AVIDANO SIMEONI
LOMBARDIA NORD EST: Provincia Est Milano (esclusi i comuni della provincia di Monza), Bergamo, Lecco
 Cell. 335.5296941
 Fax 02.3506882
 avidanosimeoni@alice.it

ESPOSITO RAPPRESENTANZE
CAMPANIA: Avellino, Salerno, Napoli Sud
BASILICATA: Potenza
 Cell. 335.6212740
 Fax 081.2140299
 alfredo-esposito@fastwebnet.it

MARCO VESENTINI
LOMBARDIA SUD EST: Brescia, Mantova, Cremona
VENETO: Verona
 Cell. 346.0831683
 Fax 0376.809741
 marcovesentini@tiscali.it

GIOVANNI PEPE
PUGLIA
BASILICATA: Matera
 Cell. 393.3334452
 Fax 080.5492313
 giovanni pepe_001@fastwebnet.it

TARGA SERGIO & C. SAS
TRENTINO ALTO ADIGE
VENETO: Vicenza
 Tel. 348.4112065
 Fax 0461.530550
 targa_s70@yahoo.it

DOMENICO ARAGONA
CALABRIA
 Cell. 337.872220
 Fax 0984.849638
 domenicoaragona@virgilio.it

VITTORINO FABRELLO
FRIULI VENEZIA GIULIA
VENETO: Padova, Rovigo, Venezia, Belluno, Treviso
 Cell. 337.478049
 Fax 0444.360172
 fabrello.v@libero.it

SALVATORE TUDISCO
SICILIA EST: Messina, Catania
 Cell. 335.8064374
 Fax 095.7270564
 info@agenziatudisco.it

RAMS DI MIRKO SPOTO
EMILIA ROMAGNA: Modena, Parma, Reggio Emilia, Piacenza
 Cell. 335.6767165
 Fax 051.6646204
 info@ramsmirkospoto.it
 mirkospoto@libero.it

RITA ITALIA
SICILIA EST: Siracusa, Ragusa, Enna
 Cell. 338.6365091
 Fax 0931.870400
 ritaitalia@gmail.com

RIEM - MARCO MALAGUTI
EMILIA ROMAGNA: Bologna, Ferrara, Ravenna, Forlì-Cesena, Rimini
 Tel. 059.468050
 Cell. 335.5488324
 Fax 059.468028
 info@ariem-riem.com

GIUSEPPE CASSARÀ
SICILIA OVEST: Palermo, Trapani, Caltanissetta, Agrigento
 Cell. 329.4207410
 Fax 091.9770384
 cassara.giuseppe54@tiscali.it

STEFANO CAMERINI
TOSCANA: Firenze, Pistoia, Prato, Livorno, Pisa, Lucca, Massa Carrara
 Cell. 347.5084765
 Fax 055.289350
 camerini.stefano@tiscali.it

PI.CO - LUCIANO COMPARETTI
SARDEGNA: Oristano, Cagliari
 Cell. 349.4977448
 Fax 070.41674
 pico.comparetti@tiscali.it

GABBI PAOLO E GABBI SIMONE SNC
TOSCANA: Grosseto, Siena, Arezzo
UMBRIA
 Cell. 348.7105920 (Paolo)
 Cell. 335.6549612 (Simone)
 Fax 0575.351998
 gabbis@libero.it
 gabbip@tiscalinet.it

PI.CO - SALVATORE PILLA
SARDEGNA: Sassari, Nuoro
 Cell. 349.4977449
 Fax 079.501493
 pico.pilla@tiscali.it

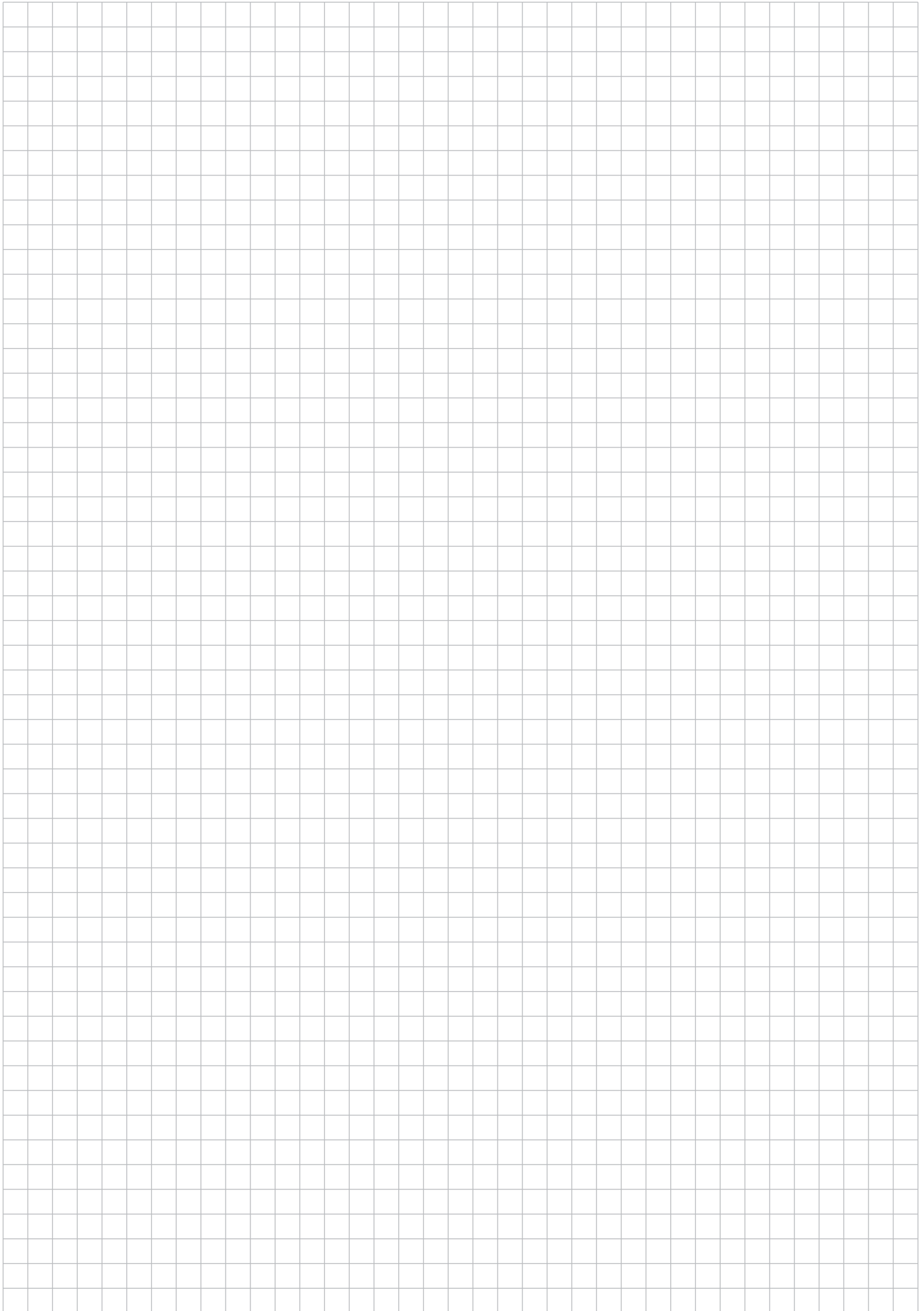

Indice generale



Artiglio prensile	151
Autoriparazione	85÷88, 119÷133, 138-139, 158÷161, 218-219
Bulini	5
Cacciaspina	5
Calibri	144-145
Carrozzeria	113÷116
Cesoie	96-97
Chiavi a "T" con bussola esagonale	82÷84
Chiavi a "T" maschio esagonale	82÷84
Chiavi a bussola a mano e accessori 1/4"	58÷62
Chiavi a bussola a mano e accessori 3/8"	62÷67
Chiavi a bussola a mano e accessori 1/2"	67÷76, 268
Chiavi a bussola a mano e accessori 3/4"	76÷78
Chiavi a bussola a mano e accessori 1"	78
Chiavi a bussola con impugnatura	81-82
Chiavi a bussola e accessori Macchina	46÷52
Chiavi a cricchetto	19-20
Chiavi a forchetta	8÷10, 267
Chiavi a percussione	10, 267
Chiavi a pipa	79÷81
Chiavi a settore	17
Chiavi a tubo	79÷81
Chiavi a zampa di gallo	65
Chiavi combinate	6÷8, 18-19, 267
Chiavi dinamometriche	42÷46
Chiavi e bussole per candele	85
Chiavi maschio esagonale con impugnatura	15, 105, 112
Chiavi maschio esagonale e Torx®	13÷17, 268
Chiavi per raccordi	12
Chiavi poligonali	10÷12, 18÷20, 267
Chiavi regolabili a rullino	17-18, 268
Coltelli e cutter	162-163, 269
Comparatori	146
Compassi	147
Dynatester	42, 46
Estrattori	133÷137, 139-140
Estrattori per viti e prigionieri danneggiati	120-121
Filiere	34÷38
Flessibili magnetici	151
Flessometri e metri	148-149
Forbici	97, 164
Forbici per elettricisti	97
Frese coniche	30-31
Fustelle	95-96
Giramaschi e girafiliera	34, 36
Giravite a battere	105
Giravite a percussione	112
Giravite BetaEasy	102÷104
Giravite BetaMax	110÷113, 269
Giravite Bimateriale	106÷109
Giravite dinamometrici	41-42
Goniometri	43, 147
Idraulica	20÷26, 268
Inseriti e portainseriti	52÷58, 113
Lampade e avvolgitori	165÷167
Lime	31, 152÷154



Livelle	149-150
Martelli, Mazzette, Mazze e Mazzuole	115÷119, 269
Maschi per filettare	32÷34, 36÷38
Microgiravite	104÷106
Micrometri	145
Moltiplicatori di coppia	40-41
Multimetri	159-160
Oliatori	157-158
Pinze a becchi lunghi e lunghissimi	89-90, 99-100
Pinze autobloccanti	91÷93
Pinze e tronchesi per elettronica	100÷102
Pinze per anelli elastici	90-91
Pinze per capicorda e capicorda	141÷144
Pinze regolabili	91, 268
Pinze universali	99, 269
Pinzette a molla	88-89, 163
Pistole termiche	167
Punte a tracciare	148
Punte per forare	26÷30
Punteruoli	151-152
Punzoni	5, 267
Raschietti	128, 152
Righe	147
Rivettatrici	155-156
Saldatori	164-165, 168
Scalpelli	5-6, 267
Scalpelli per muratori	150
Seghe a tazza	38÷40
Seghetti	154, 269
Serraggiunti e strettoi	140-141
Spaccadadi	151
Spazzole	155, 269
Specchietti	151
Spellacavi e spellafilii	98-99
Spessimetri	151
Squadre	146-147
Tagliacavi	95, 97-98
Tenaglie	95
Termometri	160-161
Troncabulloni	95
Tronchesi	93÷95, 268
Ugnetti	6
Utensili pneumatici ed accessori	168÷180

● Assortimenti e termoformati	220÷263
● Abbigliamento da lavoro	302÷324
● Accessori per funi Robur	347÷361
● Utensili antiscintilla	266÷269
● Beta collection	362÷370
● Calzature di sicurezza	270÷301
● Contenitori (borse, cassettiere, carrelli e banchi)	181÷217, 264-265
● Gamma blister	325÷329
● Soluzioni per il punto vendita	330÷346

Partnership 2009



40 years in motorsports



Beta

www.beta-tools.com